

THE ZIG WATER LEVEL GAUGE

LOTS OF ADVANTAGES

- Check the water level any time.
- No need to inspect the tank.
- Gives an accurate indication.
- No need to rely on a reserve supply.
- Helps you plan your top-ups, so you need never run out of water again.

SIMPLE TO USE

The Zig Water Level Gauge is an accurate and convenient method of showing the water level. At any time, you simply press a button and the dial immediately indicates exactly how much water there is.

CALIBRATED DIAL

The unique calibrated dial can be mounted virtually anywhere - over the sink or on the dash panel for example.

ACCURATE AND RELIABLE

Once set to suit the size of the tank, you can always rely on the dial to give an accurate indication. And the circuitry is regulated, which means you still get a true reading if the vehicle's battery is low.

EASY TO INSTALL

Any handyman (or handywoman) can easily install the Zig Water Level Gauge. You need only a few simple hand tools, and the entire installation takes just an hour or so.

SPECIAL SERVICE FOR MANUFACTURERS

The Zig Water Level Gauge takes just minutes to install during vehicle manufacture, and for bulk orders, we can supply the dial assemblies pre-set and the probes already cut to length. Special dials can also be made to suit your own design.

INSTALLATION INSTRUCTIONS

Read these instructions completely before starting work.

INSTALLING THE PROBES

1. Mark two centres on the top of the water tank, 23mm ($1\frac{1}{8}$ ") apart and drill two holes using a 6mm ($\frac{1}{4}$ ") drill.
2. Measure the overall length of the metal probes and pass them through the holes until they touch the bottom of the tank. Measure the length of the probes protruding and subtract this from the overall length to determine the internal tank depth.
3. The recommended length of the probes is 85% of the internal tank depth measurement and any excess must be cut off from the bottom of each probe by securing firmly in a vice and cutting with a hacksaw.
Example:
Overall length of probe as supplied 508mm (20")
Length of probe protruding when inserted
into water tank 127mm (5")
Therefore internal tank depth 381mm (15")
Ideal probe length 85% Of 381mm (15") 324mm (12 $\frac{3}{4}$ ")
Thus 184mm (7 $\frac{1}{4}$ ") must be cut off probe length.
4. Install the probes by passing them through the holes again. No form of fixing is necessary.

INSTALLING THE DIAL ASSEMBLY

1. Choose a suitable location for the dial. Ensure that there is clearance of at least 35mm ($1\frac{1}{2}$ ") behind the panel.
2. Mark and cut out a rectangle 65mm ($2\frac{1}{2}$ ") long and 44mm ($1\frac{7}{8}$ ") high.
3. Pass the dial assemble into the rectangular hole and attach to the panel using the screws provided.

MAKING THE ELECTRICAL CONNECTIONS

1. Connect the red wire to a fused 12V positive supply.
2. Connect the black wire to 12V negative supply (usually earth).
3. Connect the yellow wire to one of the yellow wires on the probe.
4. Connect the other probe yellow wire to 12V negative supply (usually earth). Note all cables can be extended as required using 16.02 or similar wire.

SETTING THE DIAL

1. Fill the water tank. (Note the dial cannot be set when the tank is not full).
2. With the push button "IN" adjust the thumbscrew marked "SET" until the needle on the dial lays over the number "1".
3. Your water gauge is now ready for use.

N.B. Please note that the Gauge must be calibrated every time the tank is filled.

Specifications

Power supply:

12V DC or optional 24V DC. Regulated.

Current consumption:

Uses power only during manual operation, maximum 70mA.

Operation:

By push-button switch.

Calibration:

Visual graduation, 0 (empty) to 1 (full).

Probe length:

Maximum 610mm (24"). Can be cut to length during installation or can be supplied to length required.

Probe assembly clearance height:

Approximately 20mm ($\frac{3}{4}$ ").

Dial assembly dimensions:

Fascia 82mm (3 $\frac{1}{8}$ ") wide 70mm (2 $\frac{3}{4}$ ") deep projecting 12mm ($\frac{1}{2}$ ") (including switch). Coverbox 64mm (2 $\frac{1}{2}$ ") wide 43mm (1 $\frac{5}{8}$ ") high 30mm (1 $\frac{1}{8}$ ") deep.



*We Give You
The Power*

Zig Electronics Ltd.

Units 4, 5 & 10 Phoenix Works, Thrupp, Stroud, Glos. GL5 2BU
Telephone: (01453) 731700 Fax: (01453) 731220

Installation Instructions

Read these instructions completely before starting installation.

Installing the probes

1. Mark two centres on the top of the water tank 23mm apart and drill two holes 8mm diameter.
2. Measure the overall length of the metal probes and pass them through the holes until they touch the bottom of the tank. Measure the length protruding (to the underside of the flange) and subtract this from the overall length to determine the tank depth.
3. The recommended length of the probes 85% of the internal tank depth measurement and any excess must be cut off from the bottom of each probe by securing firmly in a vice and cutting with a hacksaw. Remove any burr from the probe ends.

Example: Overall length of probe as supplied	610mm
Length of probe protruding when inserted into tank	127mm
Therefore, internal tank depth	483mm
Ideal probe length 85% of 483mm	411mm
Thus, amount to cut off probe	72mm

4. Insert the probes by passing them through the holes again. Secure with two self-tapping screws into the top of the tank. Waterproof mastic or similar may be used under the flange if required.

Installing the Gauge or Meter assembly

1. Choose a suitable location for the gauge. Ensure that there is a clearance of at least 35mm behind the panel.
2. Mark and cut out a rectangle 50mm long and 42mm high.
3. Pass the wires and then the gauge assembly into this rectangular hole and secure with the screws provided.
4. NOTE: If your tank is less than approximately 225mm deep as measured above, an adjustment will be needed to the circuit inside the back box. Carefully remove the back box assembly from the mounting-panel. Ensure that no wires are damaged or broken during this operation. Using a pair of wire cutters cut either leg of the resistor as shown in the diagram below. This will increase the sensitivity of the gauge when used with shorter length probes.

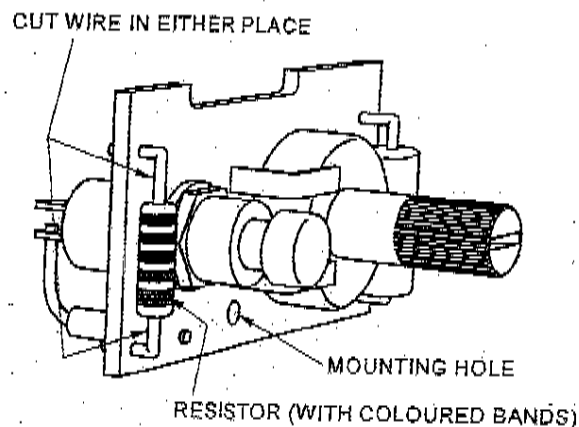

Making the electrical connections.

1. Connect the Red wire to a fused 12v positive supply.
2. Connect the Black wire to a 12v negative (or earth).
3. Connect the Yellow wire to either one of the Yellow wires on the probe.
4. Connect the other Yellow wire on the probe to the 12v negative (or earth).
5. Note, all the wires can be extended if necessary, using similar thickness cable.

Setting and using the gauge.

1. Fill the water tank
2. With the button marked "READ" pressed in, adjust the button marked "SET" until the needle lays over the "1" or "F" on the meter.
3. Your gauge is now ready for use. Just press the "READ" button to see the level in the tank.

Modification to Zig WG-4 Water Gauge for use with Short Probes (Less than 10" Long)

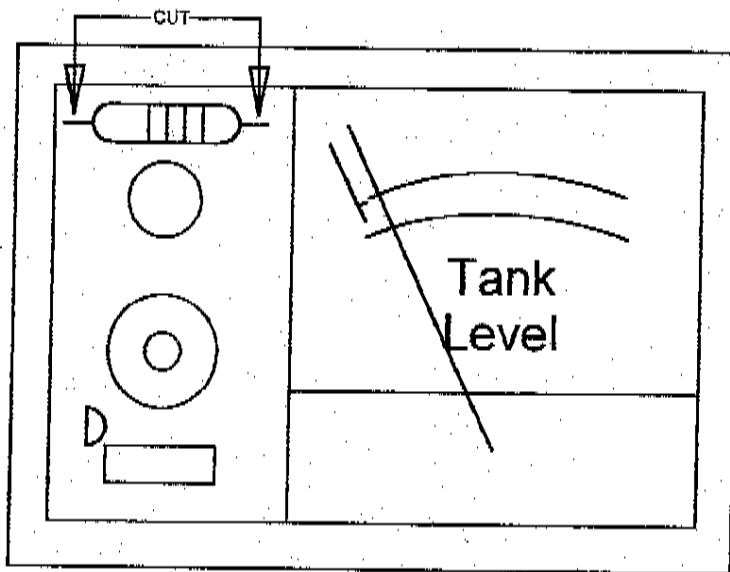

Remove Resistor by Cutting as shown above