

# DOMETIC

---

## Dometic

### MANUAL REFRIGERATOR DIAGNOSTIC SERVICE MANUAL

#### The Dometic Corporation

Corporate Office

2320 Industrial Parkway  
Elkhart, IN 46515  
219-295-5228

Warranty  
Department

205 E. Fenn St.  
LaGrange, IN 46761  
219-463-2191

Technical Services  
Department

509 S. Poplar St.  
LaGrange, IN 46761  
219-463-4858



# MANUAL REFRIGERATOR DIAGNOSTIC SERVICE 'MANUAL



## Table of Contents

	Page
Diagnostic Flow Charts	
No Operation . . . . .	D-4-1
No 120V AC Operation . . . . .	D-4-2
No Gas Operation (Piezo Igniter) . . . . .	D-4-3
No Gas Operation (Automatic Reigniter) ..	D-4-4
Operation and Diagnosis	
Dometic Manual Refrigerators. ....	D-6-1
Glossary of Terms .....	D-8-1
Service Bulletins . . . . .	D-9-1

# MANUAL REFRIGERATOR DIAGNOSTIC FLOW CHART

## NO OPERATION

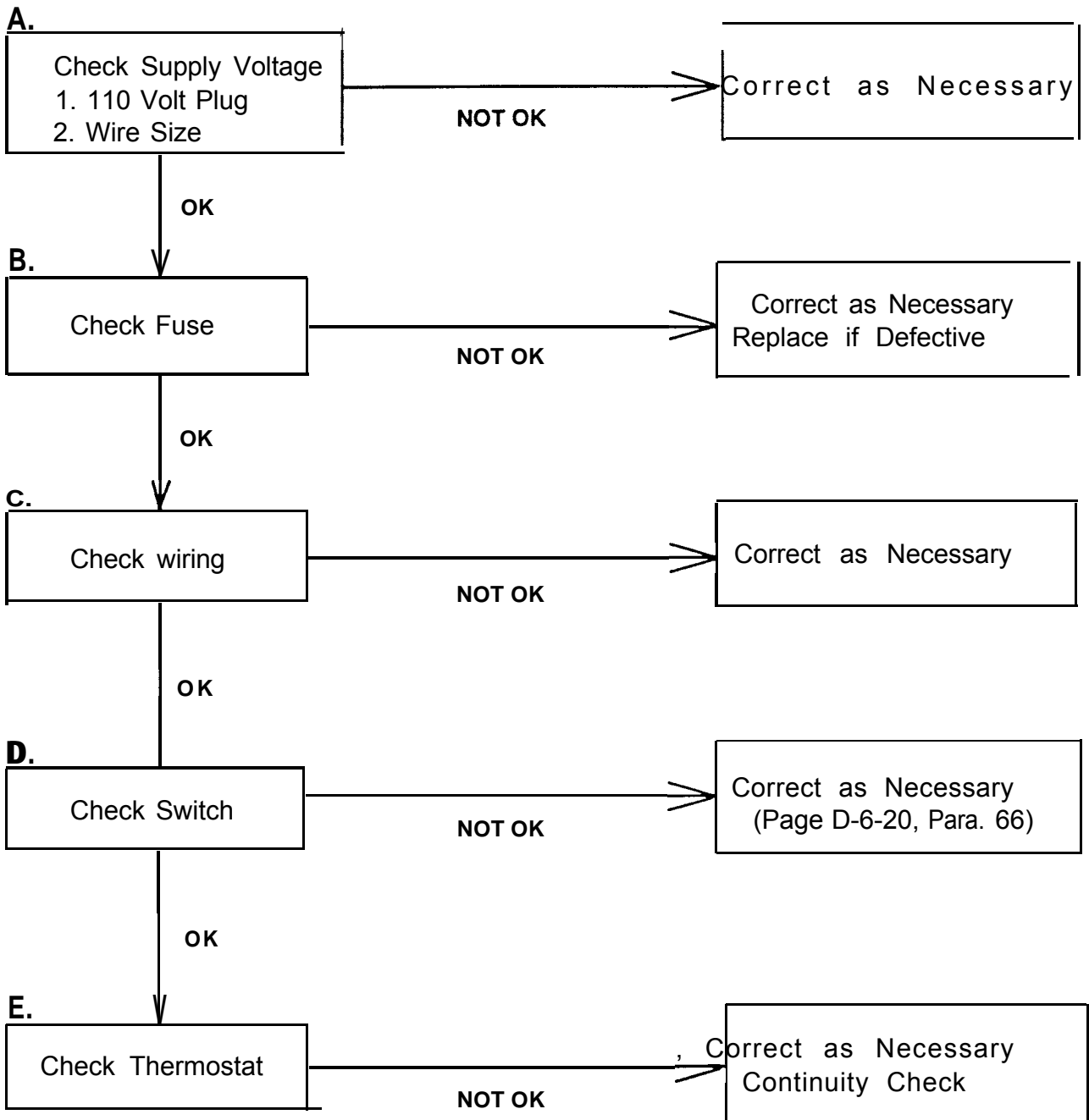

# MANUAL REFRIGERATOR DIAGNOSTIC FLOW CHART

NO 120 VOLT AC OPERATION

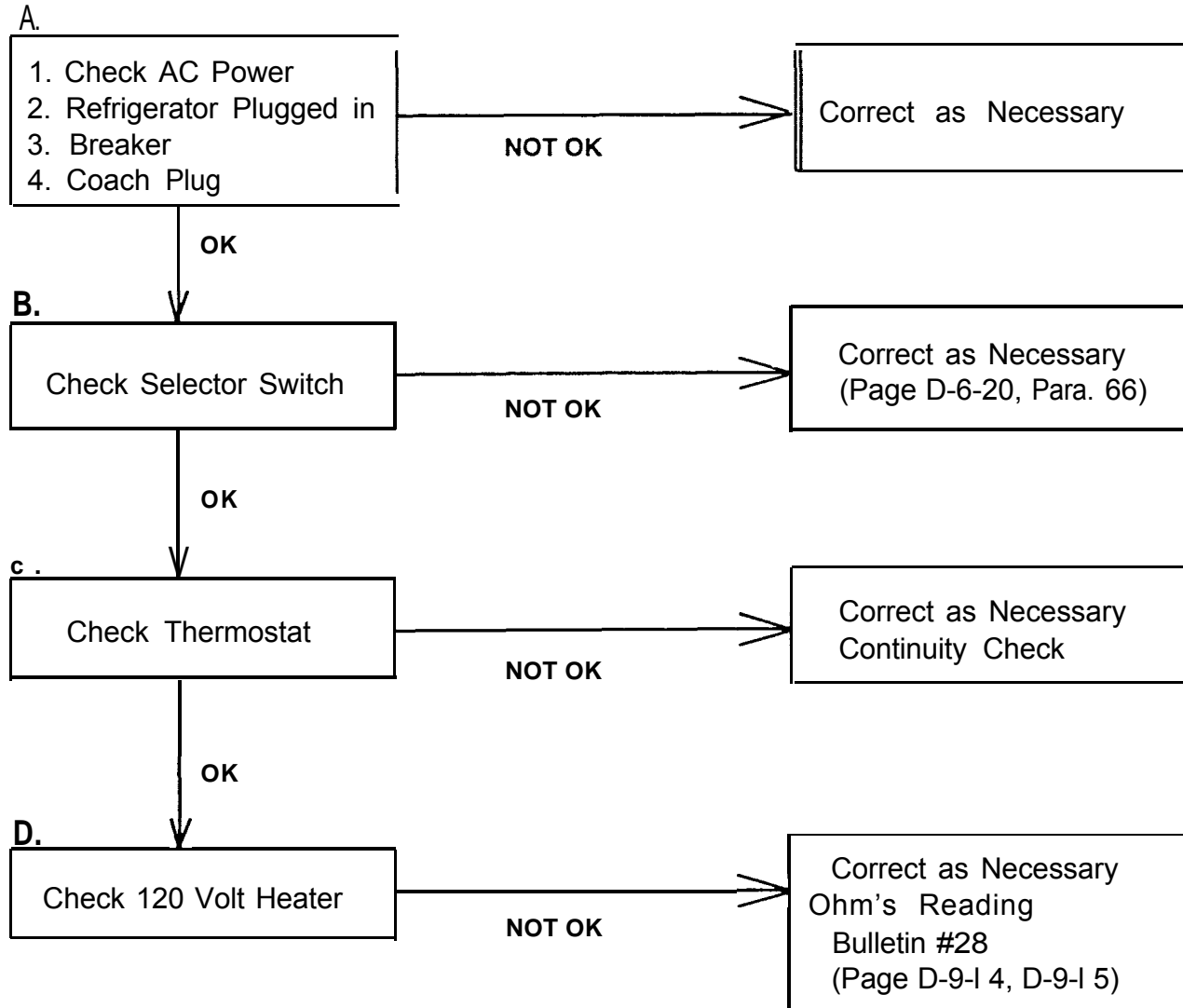

# MANUAL REFRIGERATOR DIAGNOSTIC FLOW CHART

## NO GAS OPERATION - Models Equipped with Piezo igniter

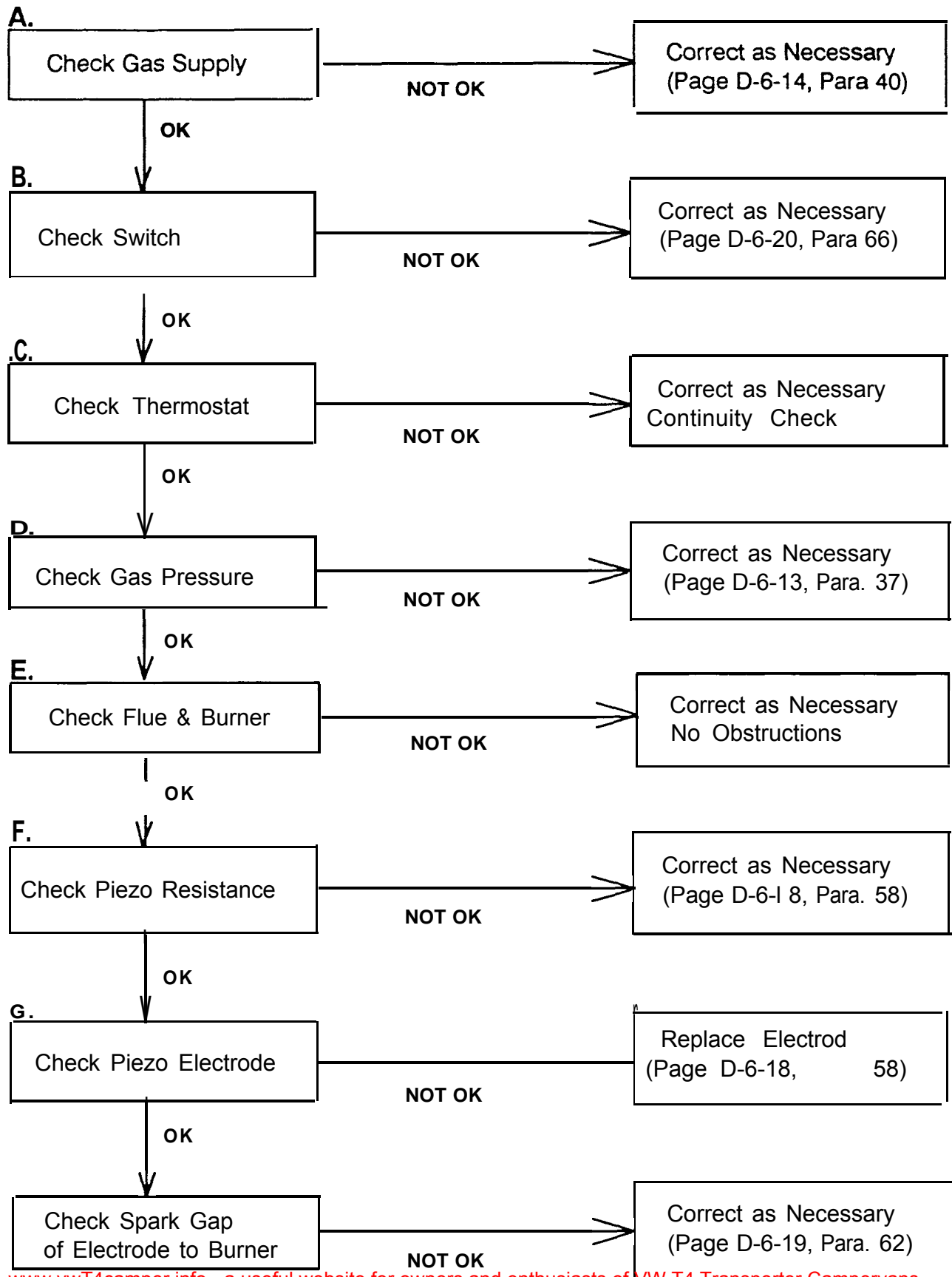

# MANUAL REFRIGERATOR DIAGNOSTIC FLOW CHART

## NO GAS OPERATION - Models Equipped with Automatic Reigniter

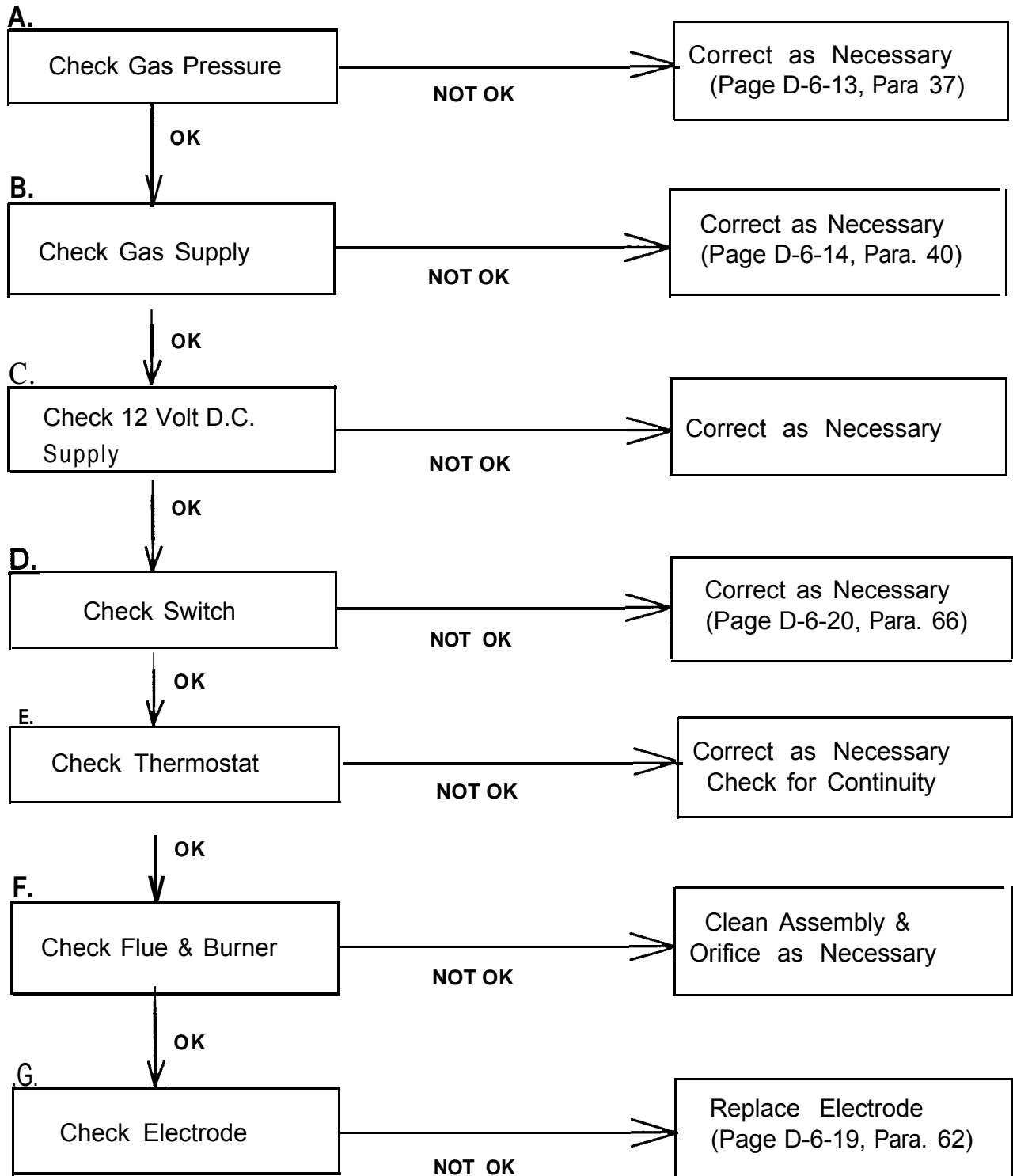





# **OPERATION & DIAGNOSIS OF DOMETIC MANUAL REFRIGERATORS**

(1)  
This is Dometic's Manual Refrigeration Diagnosis and Troubleshooting program. In this program we will discuss the way an absorption cooling unit operates, and the diagnostic procedures used to troubleshoot the complete refrigerator system.

(2)  
Before we begin extensive troubleshooting procedures on the cooling unit, let's take a few minutes to see how it operates.

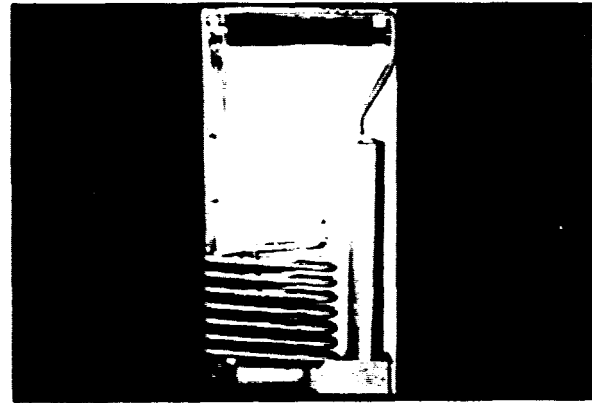

(3)  
The sealed combustion unit contains a mixture of ammonia, water and a rust inhibiting agent. After this solution is introduced into the coils, this unit is pressurized with hydrogen gas. When this system is in operation, the ammonia vaporizes in the hydrogen atmosphere and absorbs heat from inside the refrigerator.

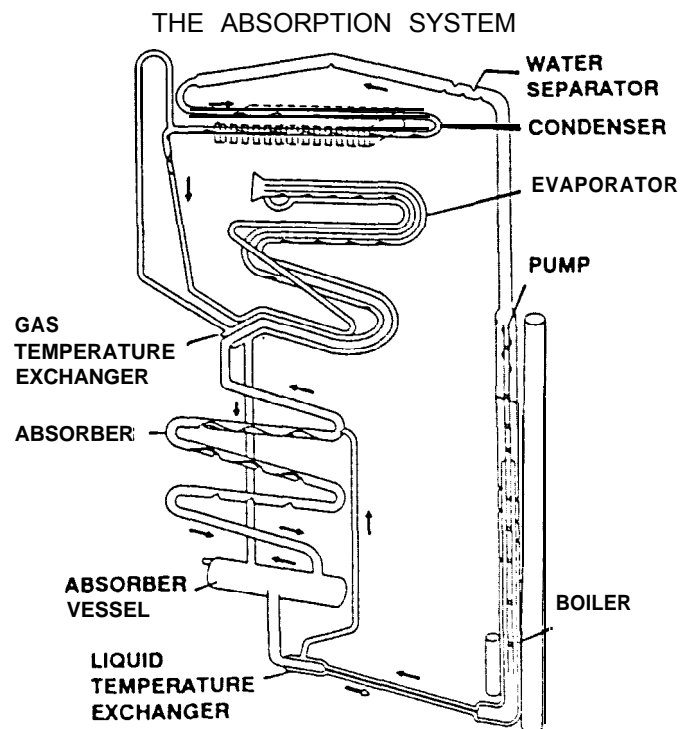

The cooling unit parts<sup>(4)</sup> that accomplish this 'cooling' or heat extraction process, include the:

**Boiler or Generator**

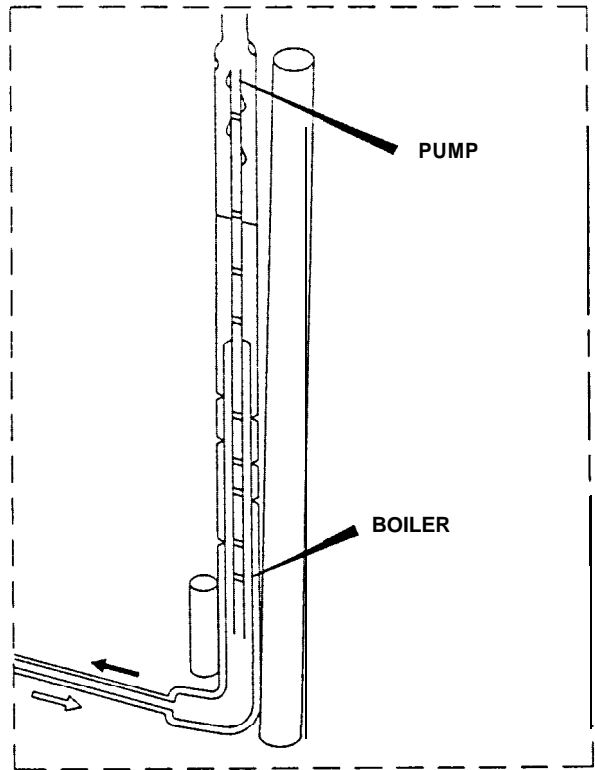

**(5)  
Condenser**

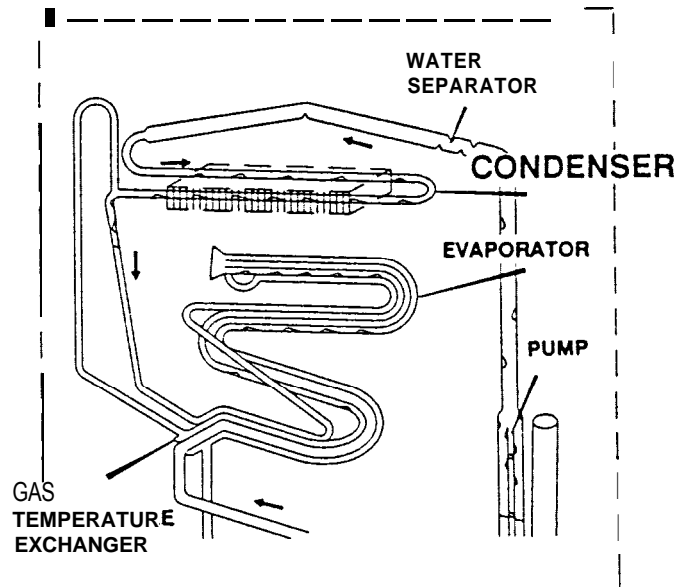

**(6)  
Evaporator**

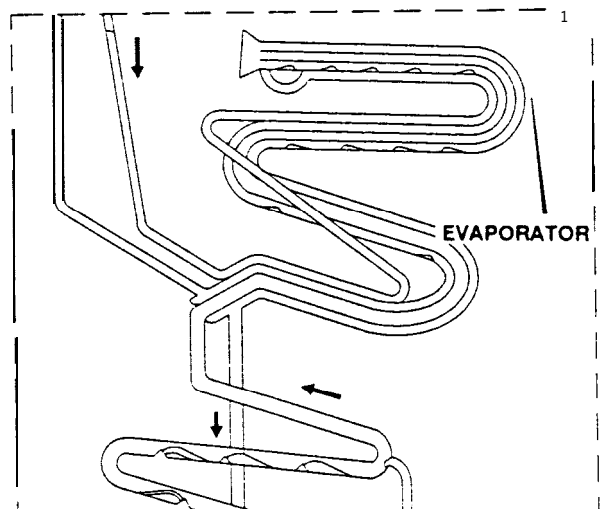

(7)  
**Absorber**

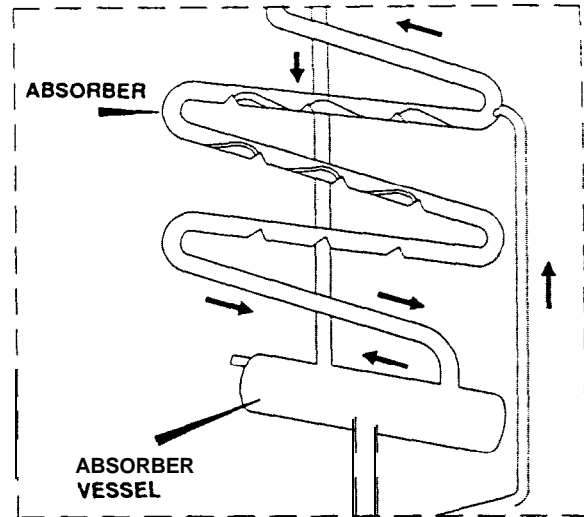

(8)

Because the self-contained cooling unit does not utilize an electric compressor or pump, the cooling coils can be operated from a variety of heat sources. LP gas, 120 volts AC and 12 volts DC heating elements are the most commonly used heat sources for recreational vehicle applications.

**THE ABSORPTION SYSTEM**

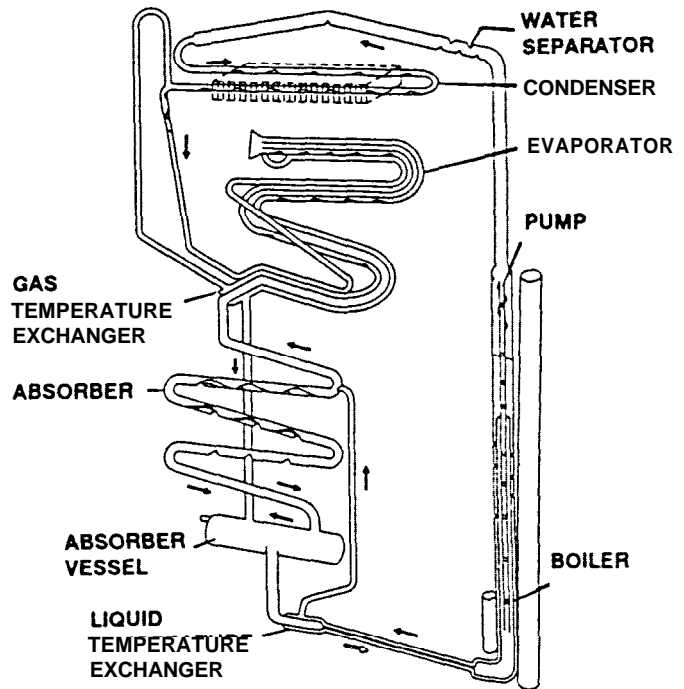

(9)

Before this cooling system can properly extract heat from the cabinet of the refrigerator, three requirements for proper refrigerator operation must be met. These are precise heat, specified ventilation and proper leveling.

**THREE REQUIREMENTS FOR PROPER OPERATION**

1. Level
2. Air Flow (Ventilation)
3. Heat

(10)

We will now take a closer look at how the cooling unit functions in normal operation. When proper heat is supplied to the boiler, ammonia vapor is produced and rises in the siphon pump, carrying with it a weak liquid ammonia solution. As seen from this drawing, the siphon pump, or pump tube, is an internal arrangement within the boiler section. The boiler section utilizes the ammonia-water liquid solution in the absorber and as it is heated, turns the solution into a strong ammonia vapor, which is needed to operate the system. This strong ammonia vapor rises from the pump tube to the condenser coil.

Any deviation from the listed amount of heat to the absorption system will alter the ammonia to water ratio, which, in turn, will decrease the cooling unit's overall efficiency. The weak ammonia solution which remains behind is diverted to the top of the absorber coils to perform a function that we will discuss in further detail later in the program.

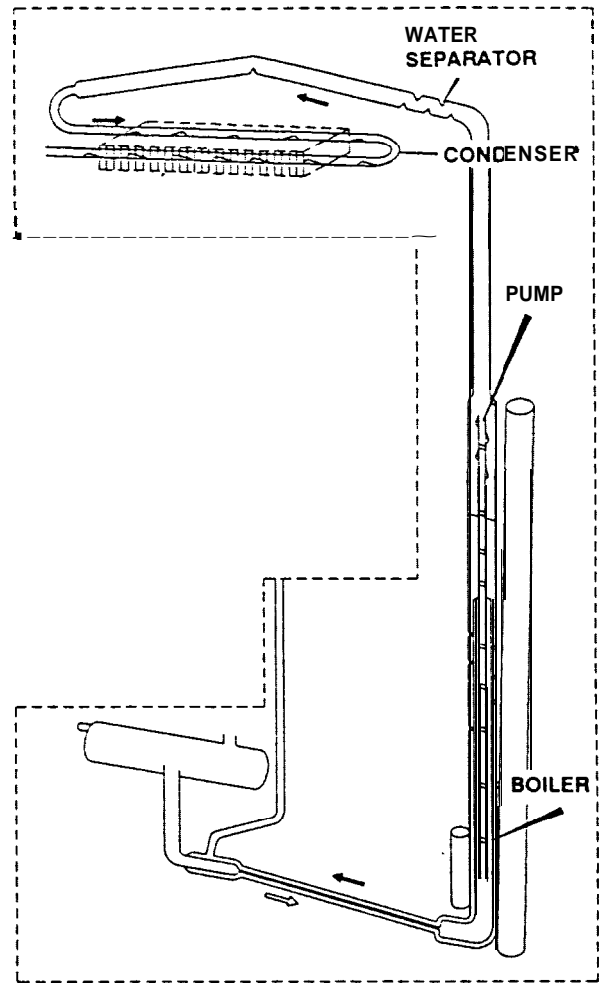

(11)

The air that passes through the condenser fins, from the venting system, removes heat from the ammonia vapor, causing it to condense into a strong liquid ammonia solution. As a liquid, it then flows to the low temperature evaporator, or freezer compartment, where it comes into contact with a hydrogen atmosphere. When this occurs, the ammonia begins to evaporate which draws heat from inside the freezer section, to the rear of the cooling unit.

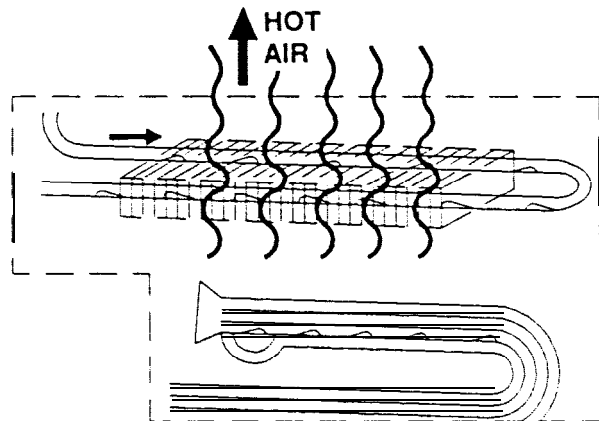

(12)

This heat is then dissipated out through the upper vent, which allows the refrigerators interior temperature to properly maintain food storage requirements. Not all of the liquid ammonia evaporates in the freezer. What is left continues to evaporate as it flows to the high temperature evaporator, or food storage compartment.

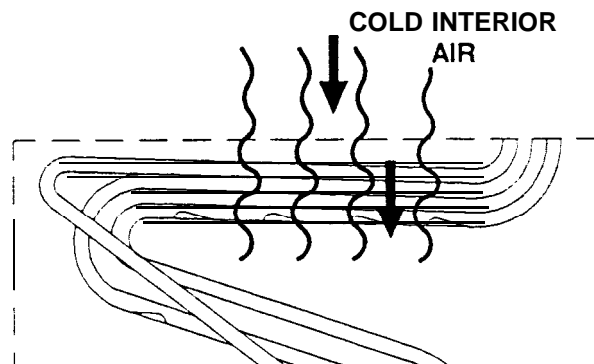

U 3)

As this process continues, the ammonia and hydrogen vapors become intermixed and flow downward into the absorber vessel. As the ammonia vapor comes in close contact to the liquid ammonia solution in the absorber vessel, the ammonia is absorbed into the liquid solution, allowing the hydrogen vapor to rise up through the absorber coils. After this absorption process, the vapor consists of mostly hydrogen with some traces of ammonia.

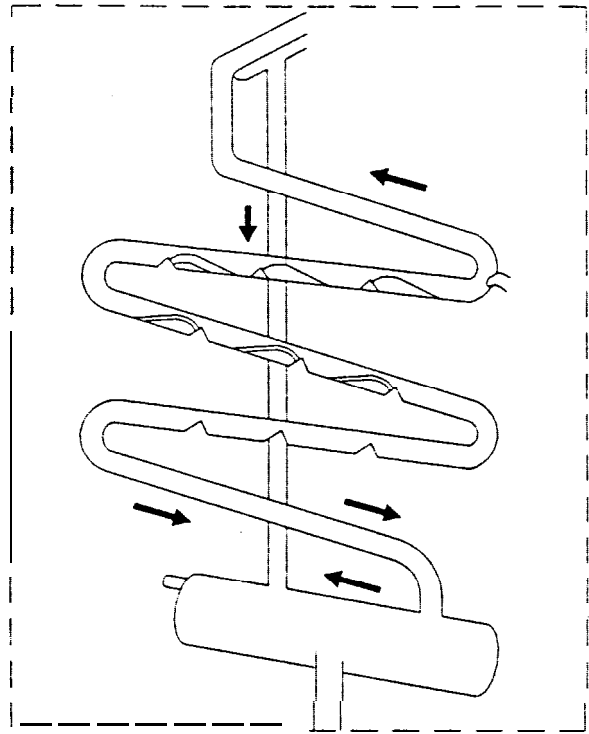

(14)

To remove the remaining amounts of ammonia vapor still present in the hydrogen, a continuous flow of weak ammonia solution is fed, by gravity, to the top of the absorber coil from the boiler. As this weak ammonia solution flows downward through the absorber, it absorbs the ammonia vapor from the mixture, allowing the hydrogen vapor to rise through the absorber coil and return to the evaporator. With the hydrogen returned to the evaporator and the ammonia remixed into solution in the absorber vessel, the cooling process can continue.

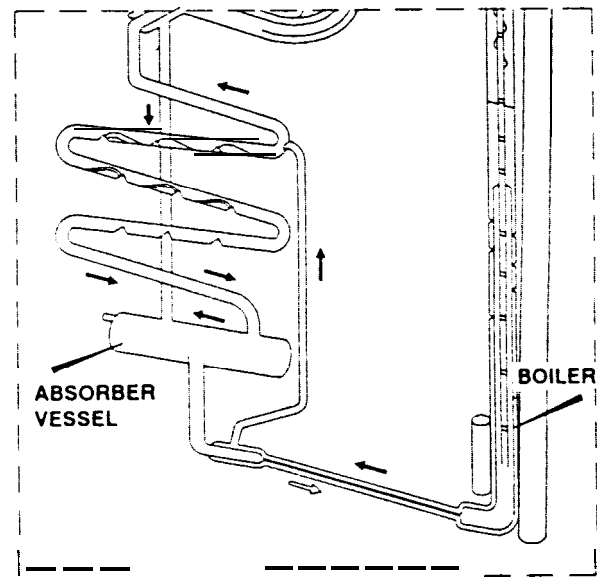

(15)

Now that we have a basic understanding of proper cooling unit flow and operation, let's take a step-by-step look at the three requirements for proper cooling unit operation. Please note it is essential that these three requirements be diagnosed before attempting to diagnose the cooling unit. A problem with leveling, heat input or ventilation may lead you to think that the cooling unit is faulty, when actually it is not. This causes an increased expense to you, the customer, and valuable shop time is wasted because of incorrect diagnosis. By following and checking the three unit requirements, costly diagnostic errors can be eliminated.

## THREE REQUIREMENTS FOR PROPER OPERATION

1. Level
2. Air Flow (Ventilation)
3. Heat

(16)  
Since the absorption system utilizes no mechanical pumps or compressors to circulate the refrigerant within the system, proper leveling is required to provide correct refrigerant flow in the gravity-feed system. Without proper leveling, refrigerant within the cooling coils will collect and stagnate at certain areas. When this happens the cooling process will stop.

(17)  
On the older style cooling units equipped with square boiler box covers, this condition can cause permanent cooling unit failure. As we can see from this drawing, square boiler box cooling units utilize an exposed siphon pump tube which will become excessively superheated in an out-of-level condition. This can allow the rust inhibiting agent to chemically break down and permanently block or restrict the normal refrigerant flow through the pump. Shaking, tipping or so called 'burping' the refrigerator will not loosen or dislodge the blockage. The only recommended service procedure is to replace the cooling unit. To prevent this occurrence, proper leveling is of utmost importance when the RV is parked for any length of time.

## THREE REQUIREMENTS FOR PROPER OPERATION

### 1. Level

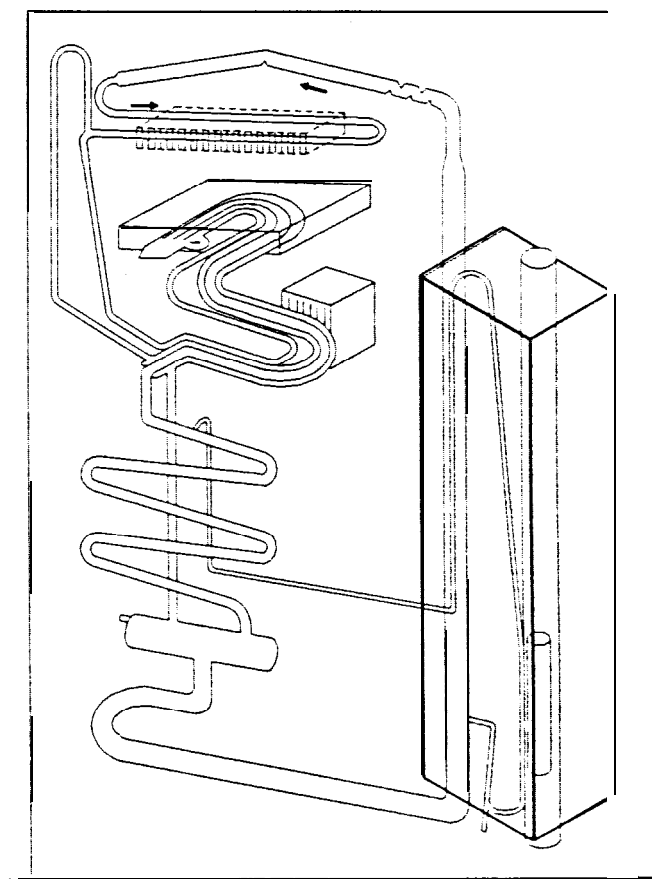

REFRIGERATOR IS TO BE LEVEL

(18)  
To level these units, the spirit or bubble level should be placed in the approximate front and center of the floor of the freezer compartment. The coach should then be positioned so that at least 3/4 of the bubble is within the required mark while the refrigerator is in operation. REMEMBER: Failure to properly level a **square boiler box** can result in a lack of cooling or permanent damage to the cooling unit. When the vehicle is moving, leveling is not critical as the rolling and pitching movement of the RV will keep the solution in motion, preventing the solution from accumulating in the piping.

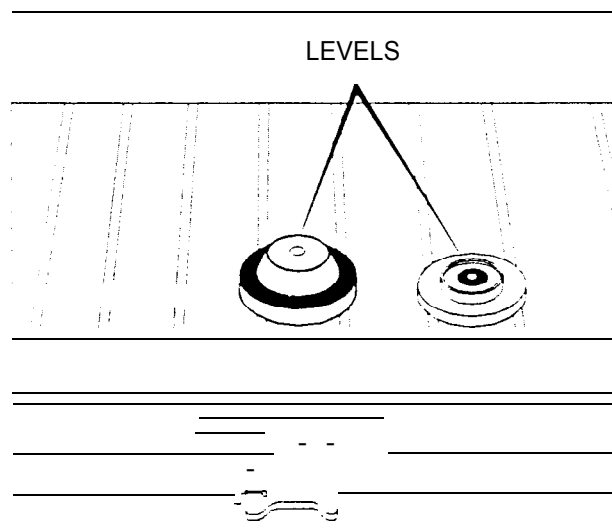

(19)

In recent years Dometic has engineered a new type of cooling unit that utilizes an improved siphon pump tube design which drastically reduces the possibility of permanent damage to the coils if operated in an out-of-level condition, or too much heat is generated at the boiler section. As we can see from this drawing, the siphon pump tube is enclosed in the design and is surrounded by a weak ammonia solution, which will protect the pump tube from abnormally over-heating. This type of unit; however, does not eliminate the need for proper leveling. The unit still requires gravitational flow to provide the proper cooling process, and if leveling is outside the necessary limits, cooling will dramatically slow down or stop completely. The cooling coils are not normally damaged in this fashion and once proper leveling is maintained, the cooling process will resume.

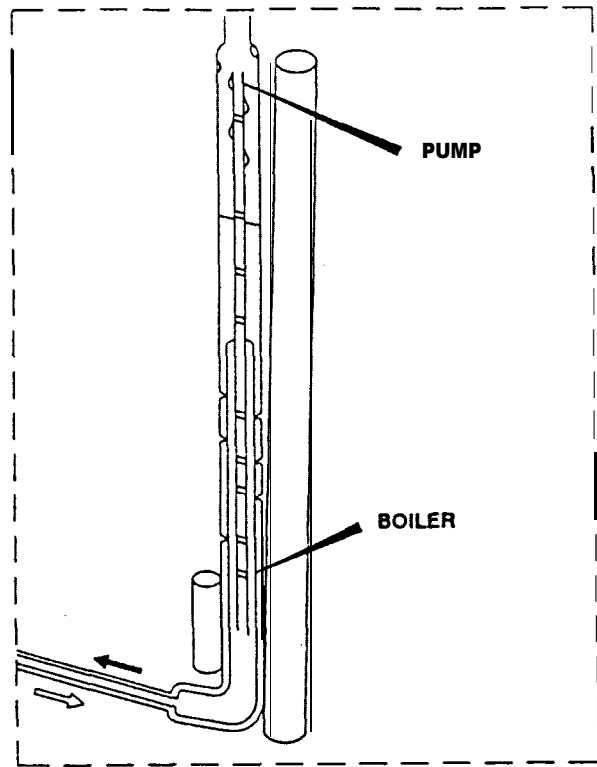

(20)

Spirit or bubble levels are no longer being supplied with the new style refrigerators as the RV or vehicle only needs to be leveled so it is comfortable to live in, with no noticeable sloping of the floor or walls. For diagnosis, the new style cooling units that incorporate the protection boiler system, can be differentiated from the older style coils by the shape and design of the outer boiler box cover on the rear of the cooling unit. These units will incorporate a circular metal cover,



(21)

... while the older style utilizes a square shaped enclosure. We will discuss diagnosis and troubleshooting of these units in more detail later in the program.





(22)

The coach vent system must be able to provide a way to direct the hot air, produced by the action of the cooling unit, out away from the installation of the refrigerator.

(23)

In a good installation there should be as little open space as possible surrounding the sides and top of the refrigerator to achieve proper air flow. All potential dead air pockets should be blocked or baffled to insure that heat from the cooling unit won't be trapped in these spaces and reduce efficiency. In addition, the cooling unit should be at least one inch from the nearest surface made of combustible materials. Please follow the installation manual for proper dimensions and clearances.

RVIA requires that the refrigerator be installed in such a manner as to provide complete separation of the combustion system and the interior atmosphere of the recreational vehicle. This regulation requires all seams and joints in the enclosure be sealed. The under-counter installation is different. The addition of a metal chute the width of the enclosure, that extends from the upper side vent, will help eliminate the possibility of dead air pockets. It helps direct the hot air out the exhaust vent. The best method for venting the absorption refrigerator is with a lower side vent and a roof vent. Using proper Dometic vents will give you sufficient intake and exhaust areas for ventilation

(24)

Heat application to the boiler section of the cooling unit must be within the designed BTU's. Never oversize the heating element on AC or DC power source. Always use the proper size orifice for gas modes. As explained earlier, any deviation will cause a potential cooling unit failure.

## THREE REQUIREMENTS FOR PROPER OPERATION

1. Level
2. Air Flow (Ventilation)

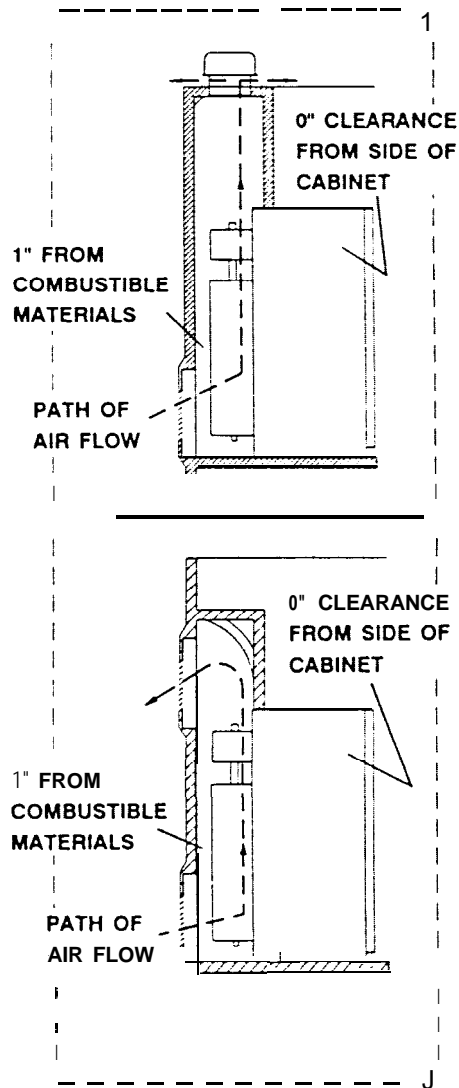

## THREE REQUIREMENTS FOR PROPER OPERATION

1. Level
2. Air Flow (Ventilation)
3. Heat

(25)

Three things must be remembered when diagnosing a cooling unit:

First, circulation within the cooling unit is **totally gravitational**. This means proper leveling is important.

Second, heat - created to boil the ammonia - now has to be dissipated into the surrounding air. Heat from the absorber and condenser must also be dissipated so as to cool the ammonia sufficiently.

Third, proper heat application at the boiler section.

### THE ABSORPTION SYSTEM

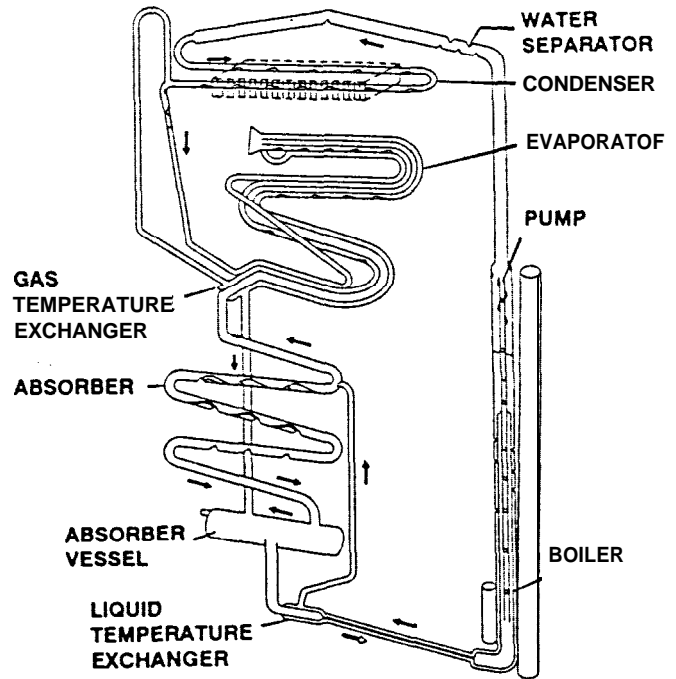

(26)

When diagnosing a cooling unit, remember this is the only part we cannot field check with test equipment, yet it is the simplest and quickest part to diagnose.

## DIAGNOSING THE COOLING UNIT

(27)

After the unit has been operating for approximately one hour, carefully touch the unit at the boiler box and the absorber area. These areas should be approximately the same temperature, regardless of the ambient temperature. Equal heat between the boiler and the absorber indicates the fluid circulation within the unit is good.

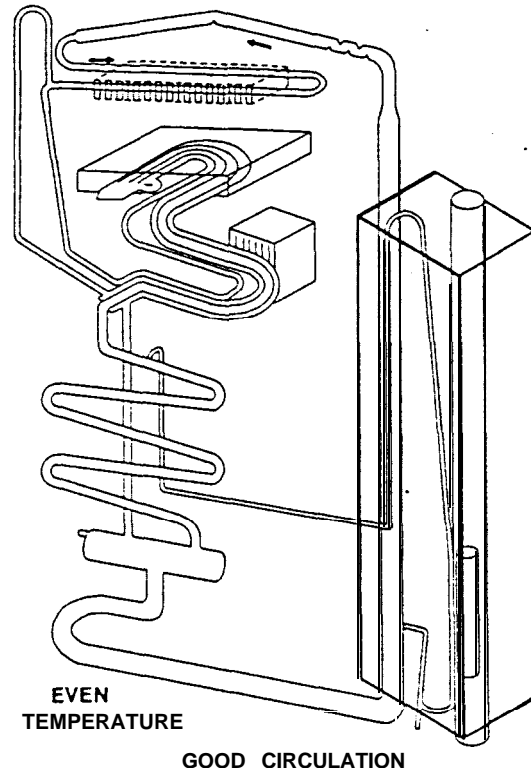

(28)

One of the faults with a cooling unit is a blockage. This can happen when the unit is operated off-level, or if too much heat has been applied to the boiler area. To the touch, this unit will be extremely hot at the boiler with little warmth at the absorber. In other words, no circulation.

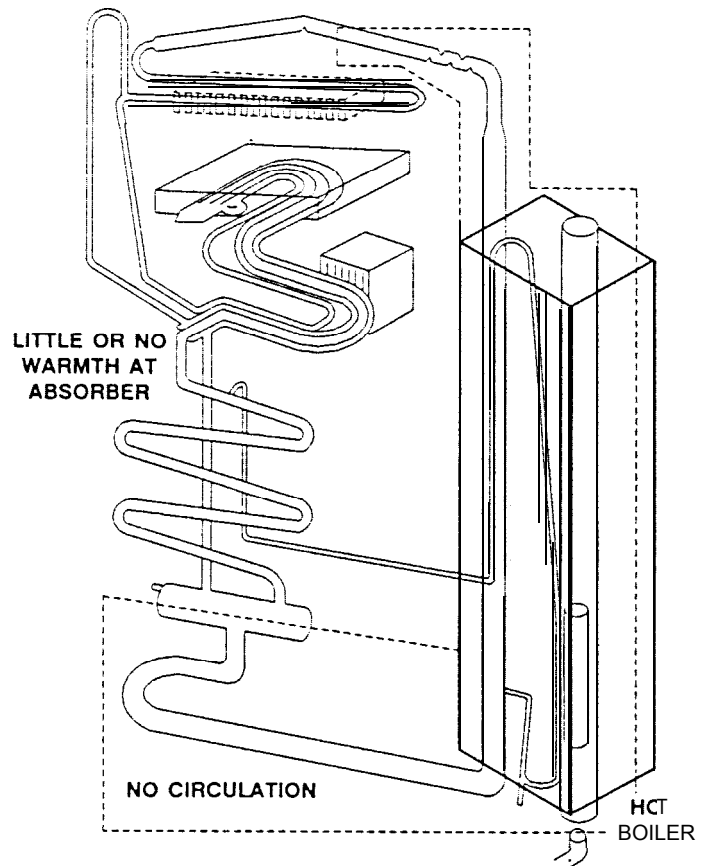

(29)

This type of fault means a lost charge. It is known as a 'leaker'. To the touch, this unit will be warm at the boiler and extremely hot at the absorber. In this condition we are still boiling ammonia but have no hydrogen for evaporation.

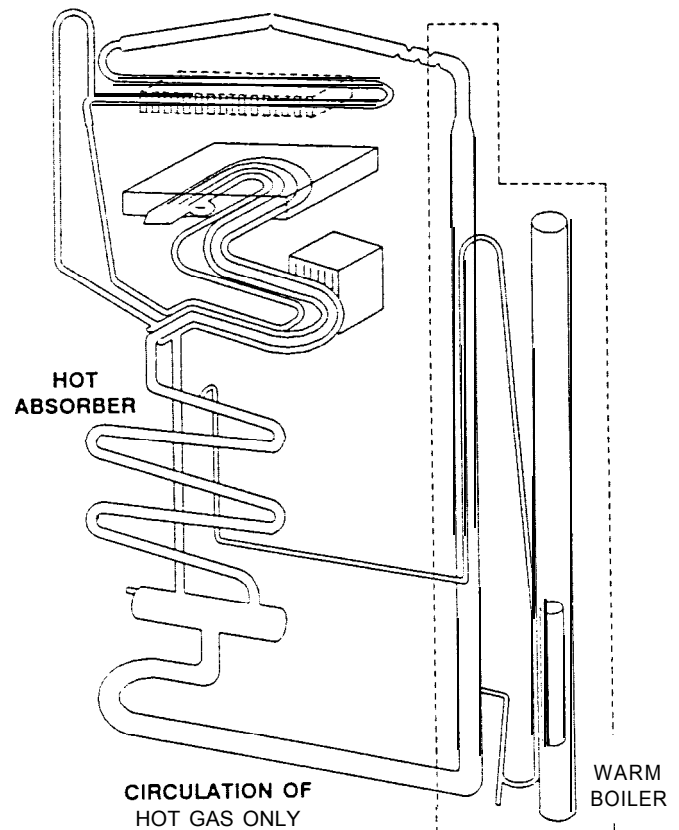

(30)

The following section of the program examines the Dometic manual refrigerator's gas and electrical systems. Dometic refrigerators are designed for both piezo and automatic ignition. Both systems will be covered in this presentation.

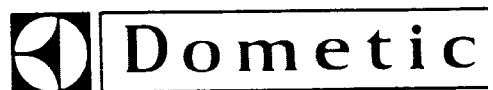

(31)  
Let's look at the current Dometic refrigerators  
and see how the gas flows.

# UNDERSTANDING THE GAS SYSTEM

(32)  
Gas flows from the gas line to the shut-off valve  
and to the connection piece.

SHUT-OFF  
VALVE

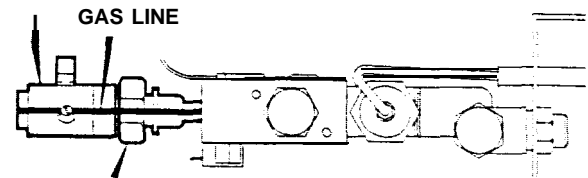

CONNECTION  
PIECE

(33)  
into the combination gas and electric thermostat

COMBINATION  
GAS & ELECTRIC  
THER.M.O.S.T.A.T

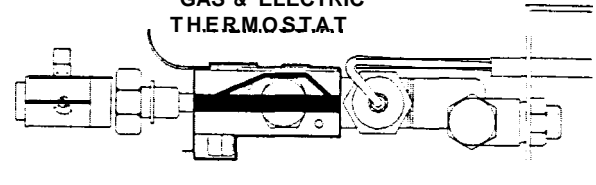

(34)  
through the safety valve thermocouple

SAFETY VALVE/  
THERMOCOUPLE

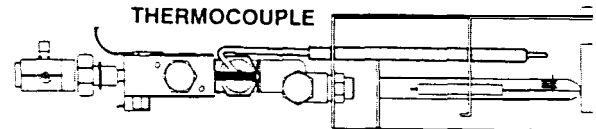

test housing

(35)

PRESSURE  
TEST  
HOUSING

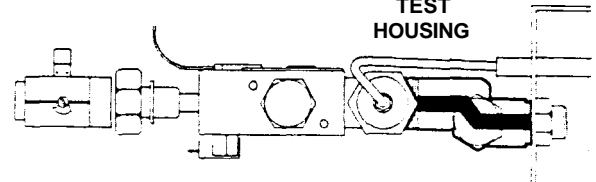

(36)  
 and onto the orifice and burner assembly.  
 Remember that except for the connection piece,  
 all fittings are O-ring sealed. **Whenever the  
 system is separated the O-rings must be  
 replaced.**

ORIFICE & BURNER  
 ASSEMBLY

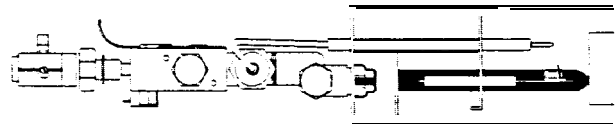

(37)  
 To diagnose the gas system, connect a  
 manometer to the test point. With the  
 thermostat on maximum you must have 11  
 inches water column pressure at this point. **If  
 you have 11 inches pressure, your problem  
 is to the right of the test point. If you do not  
 have 11 inches water column pressure, the  
 problem is to the left.**

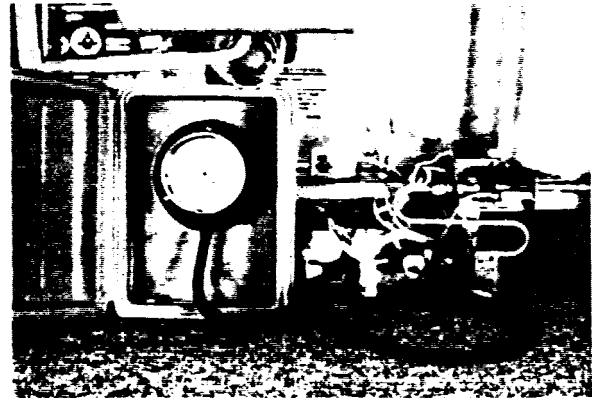

(38)  
 Let's take a closer look at the gas thermostat.  
 In this drawing we will review how a thermostat  
 functions. When the thermostat is working  
 properly, the manometer will read line pressure  
 when set at maximum and the refrigerator is  
 trying to cool. From this drawing you can see  
 the gas flow when the refrigerator is trying to  
 cool. The gas flows through the thermostat at  
 line pressure without restriction. The valve is  
 open at this time.

DIAL SHAFT

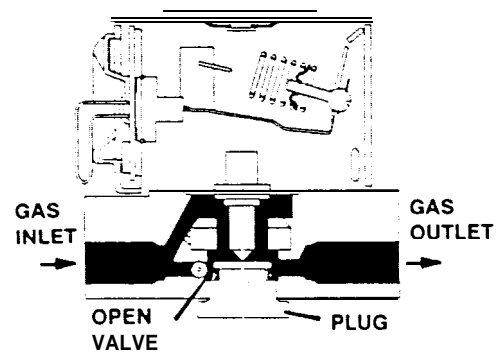

(39)  
 The valve is now closed and the gas must flow  
 through the by-pass screw; the gas is now  
 diverted through the by-pass screw, which  
 regulates the size of the low flame. This  
 condition can only exist when the refrigerator is  
 cold or the thermostat is set to minimum or off.  
 If the sensing tube has lost its pressure, even  
 with the thermostat set on maximum, you will  
 have only low flame.

DIAL SHAFT

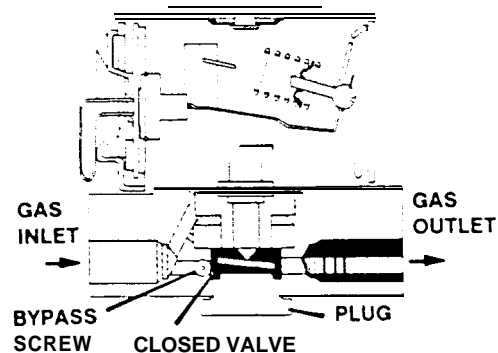

(40)

The most efficient way to diagnose the gas system would be to first connect the gas manometer to the pressure test point. With the thermostat set at maximum you must have 11 to 12 inches water column pressure for the refrigerator to operate properly. If your manometer reads higher than 11 to 12 inches water column pressure, the tank regulator is adjusted to high, readjust it. Make sure the gas system has at least 50% of the coach's LP appliances on at the time the system is being adjusted. If the manometer reads 11 inches, the problem of no cooling lies in the burner assembly, flue pipe or venting.

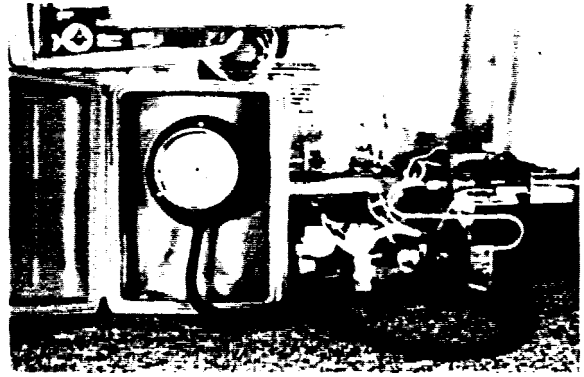

(41)

If you have less than 11 inches water column pressure, the next step would be to remove the by-pass screw.

NOTE: The by-pass screw reduces the pressure and volume of gas to the burner.

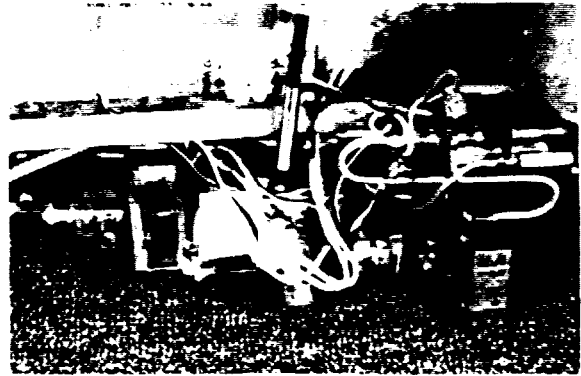

(42)

Shut off gas supply at the back of the refrigerator. Remove the by-pass screw from the top of the thermostat,

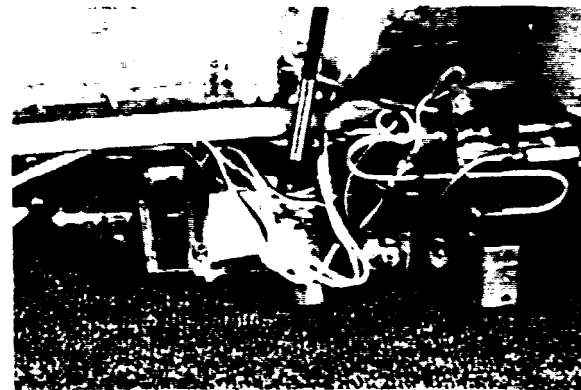

(43)

Use a by-pass screw that does not have the small O-ring at the bottom. Reinstall this by-pass screw into the thermostat.



(44)

Turn on the main gas supply and take a reading. If the manometer now reads 11 inches, the thermostat is defective and must be replaced.

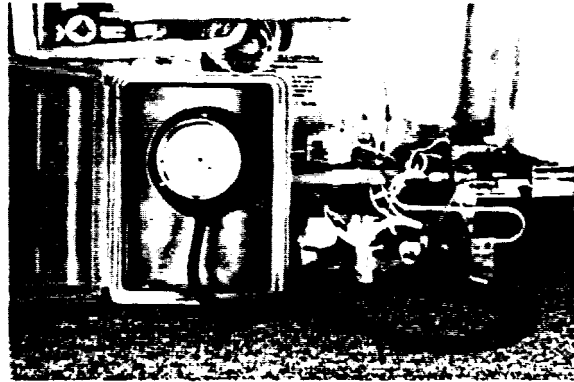

(45)

If the by-pass screw test shows no change in gas pressure, the problem lies with the gas supply to the refrigerator. Shut off the gas supply, remove the by-pass screw, replace it with one that has an O-ring and turn on gas supply. Remember to check for a gas leak. At this time we will take a look at the rest of the gas system.

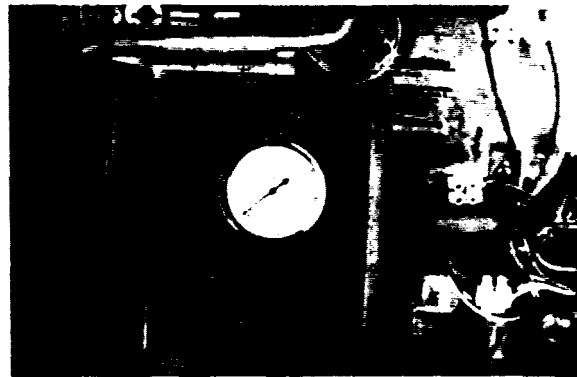

(46)

The safety valve, or flame failure safety device, consists of a brass alloy valve housing and cap, an electro-magnet, and a thermocouple, which generates 14 to 30 millivolts when heat is applied to the tip. It is used to energize the electro-magnet in the safety valve. The purpose of this device is to insure that the flow of gas is shut off in the event flame is lost at the burner. If this should occur, the thermocouple cools, the magnet loses its magnetic field and the valve closes. Most failures of this device are related to the magnet, not the thermocouple. Should this happen, the complete safety valve should be replaced.



(47)

Once the gas has been allowed to pass through the safety valve, it flows to the gas jet and burner. These have been specifically designed to eliminate most of the normal maintenance required due to the corrosive contaminants in the gas, as well as soot and rust which fall from the flue pipe. The jet has an **orifice made of an industrial ruby which has been laser-beam drilled.** Each model of Dometic refrigerator uses a different size orifice in order to maintain the required amount of heat at the siphon pump. To clean the jet and burner, soak them **in an alcohol base solvent and allow to air dry. DO NOT use a pin or needle.** This will distort or shatter the orifice.

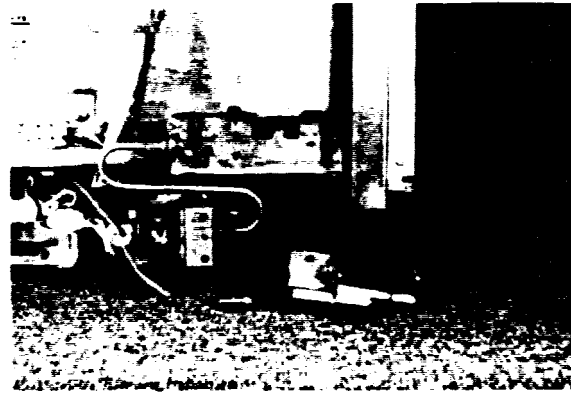

(48)

If you determine that **disassembly is required, be aware there are two model designs for manual refrigerators.** The design pictured here will be discussed first.



(49)

Shut off the main gas supply, then disconnect at the back of the refrigerator. Remove the cover over the thermostat and burner protection cover at the right,

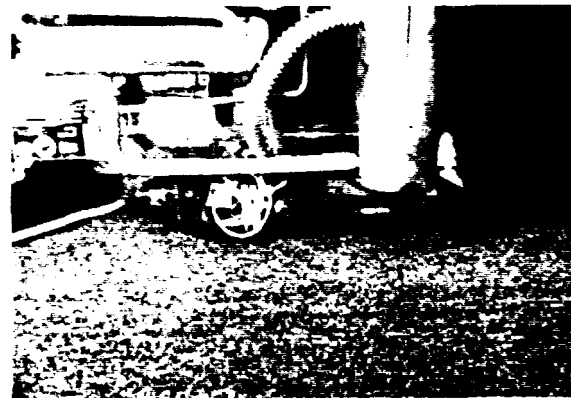

(50)

Now disconnect the 12 volts at the terminal block and unplug the 120 volt cord. Remove the two mounting screws on the left and pull the metal locking arm out from under the burner housing.

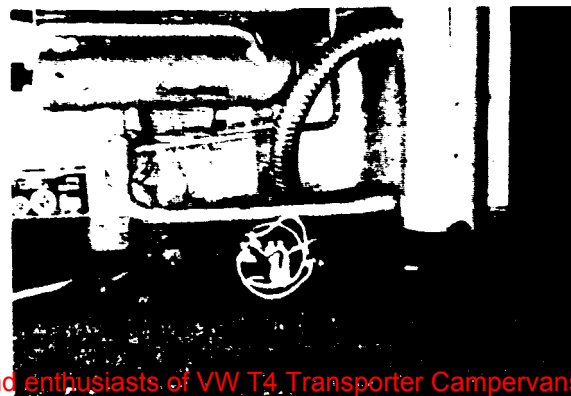



(51)  
The control assembly will now drop down and can be pulled outward for service.

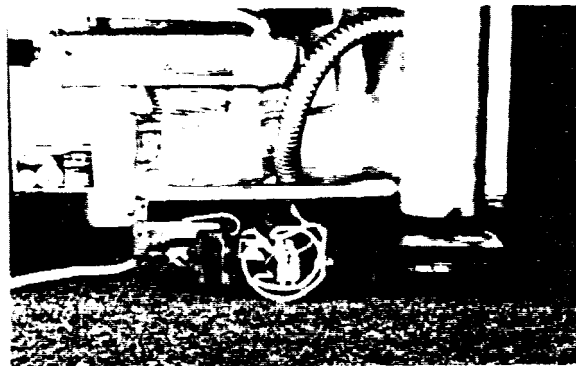

(52)  
Pictured here is the other model design. Make sure the main gas supply has been shut off and disconnect the gas supply line at the refrigerator.

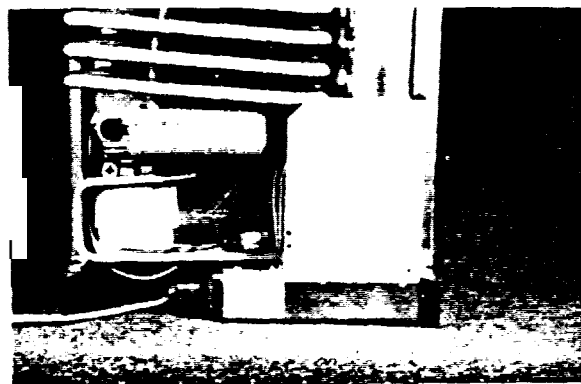

(53)  
Remove 3 screws on the burner cover plate. The sheet metal assembly should now slide out from the back of the refrigerator.

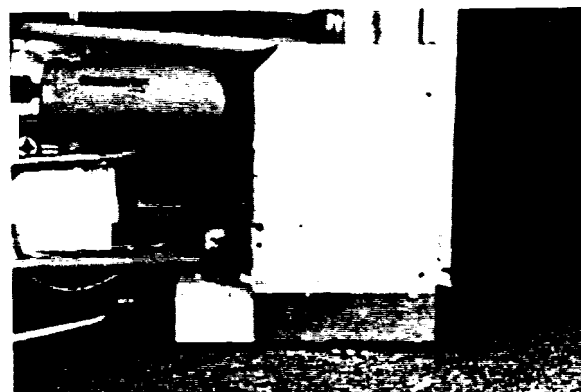

(54)  
Remove the 2 screws from the plastic cover. Also the 2 screws on the left and 2 screws on the right of the metal bracket.

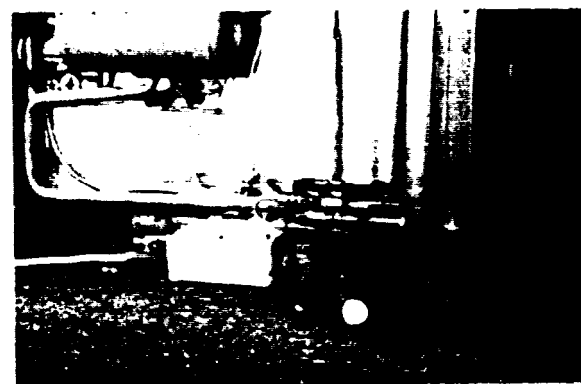

(55)

There are 3 screws in the burner area that must also be removed. Please note - these are machine screws, not sheet metal type. It is important for them to be reinstalled in this area only.

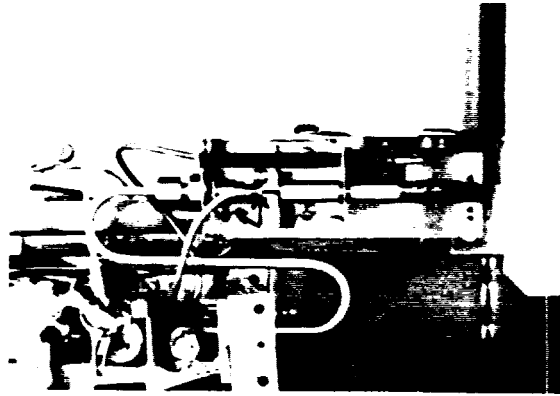

(56)

The control assembly will now drop down and can be pulled outward for service.

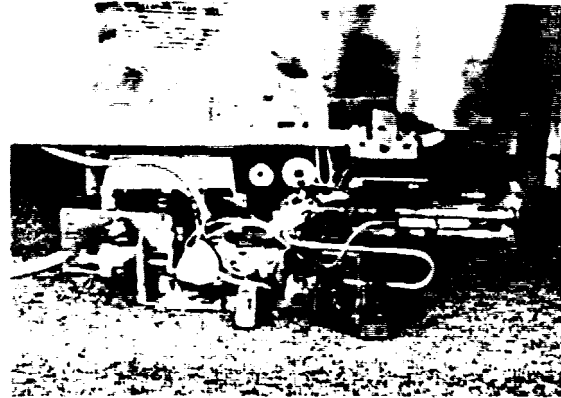

(57)

On the present line of manual refrigerators we use one of two methods of igniting the burner flame. Shown on the right is the piezo system; on the left is the igniter reigniter.

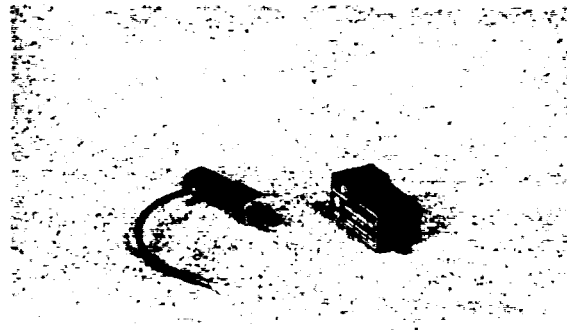

(58)

The piezo lighter is a self-contained assembly which generally -does not need maintenance. When the button is 'pushed, a spring loaded striker creates a spark. If **there is** no resistance when pressing the button, the piezo igniter is defective and must be replaced. If the piezo snaps or has resistance when the button is pushed, but there is no spark, the problem lies in the electrode or electrode wire.

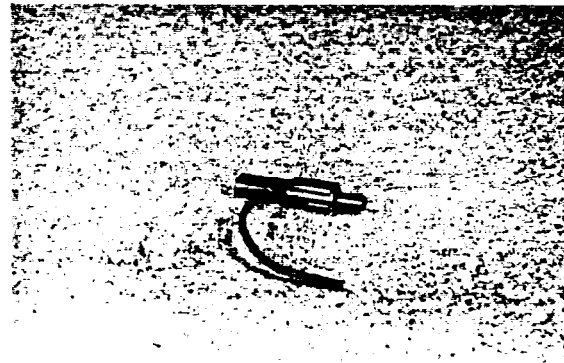

(59)

The igniter reigniter, used on certain Dometic model refrigerators, operates on 12 volt current. On gas operation the igniter senses the resistance through the flame between the electrode and burner. When there is no flame at the burner, the resistance is high and the igniter begins sparking to light the burner. As soon as the flame is lit, the resistance between the electrode and burner drops and the igniter stops sparking. The resistance is monitored by the igniter, and, if for any reason the flame goes out, the igniter begins sparking until the burner is lit. This insures that the flame will always be lit when desired. Each time the igniter reigniter system sparks, a light will illuminate on the lower left front corner of the refrigerator.



(60)

If the electrode does not spark first, make sure the igniter is receiving 12 volts. If the igniter is receiving 12 volts and produces no spark, it must be checked for operation.

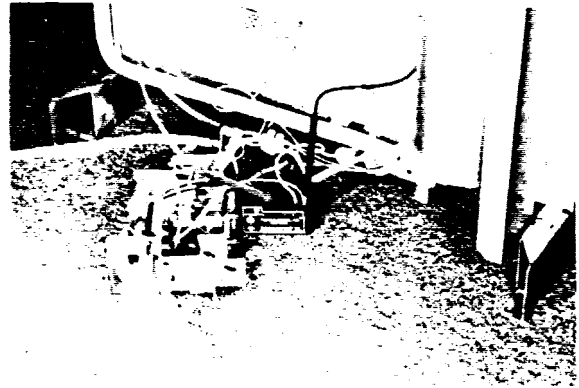

(61)

Turn the refrigerator off and remove the wire between the electrode and igniter. Now turn the refrigerator to the gas mode. If no internal clicking sound is heard the igniter is defective. It is important to remove the high voltage wire that goes to the electrode from the igniter when you are checking the igniter for operation. The high voltage wire and the electrode can be shorted to ground causing the igniter reigniter to think that the flame is lit, resulting in no spark on gas operation.

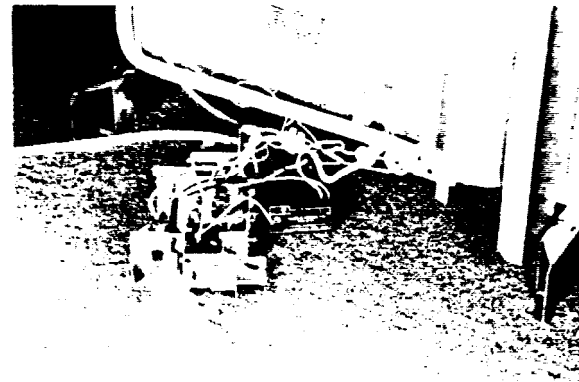

(62)

The distance between the tip of the electrode and the burner, known as the spark gap, should be  $3/16$  of an inch. A greater distance will create a slow spark causing the light to blink. A lesser distance will create a fast spark that may not light the burner.

### SPARK GAP

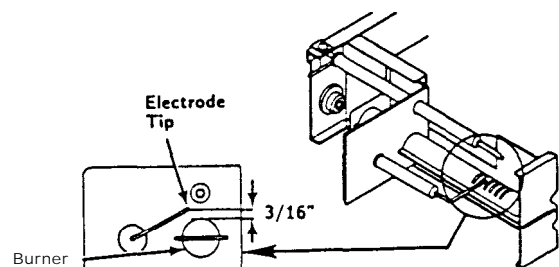

(63)  
The Electrical System

# THE ELECTRICAL SYSTEM

(64)

The electrical system consists of a combination switch assembly, heating element and thermostat. The quickest method of diagnosing the electrical system would be testing for continuity of components.

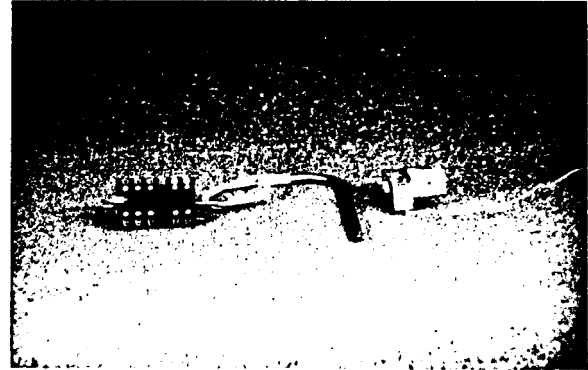

(65)

Following the wiring diagram, the component that does not show continuity would be suspect.

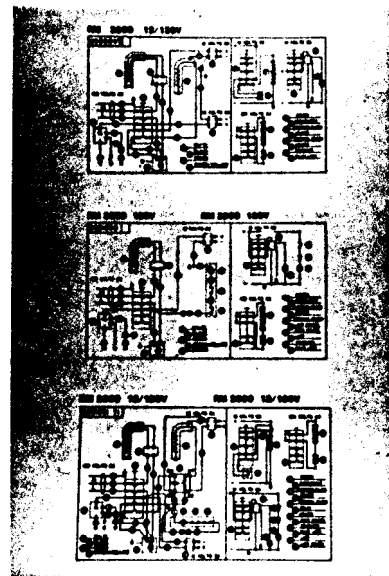

(66)

The selector switch should be checked for continuity in the following manner. Remove all wires from the assembly. Continuity should exist between terminals 1 and 1A and 2 and 2A for the DC mode. When the switch is put in the gas mode, you should have continuity between 3 and 3A if the unit has an igniter reinitier.

For the AC mode you should have continuity between 4L and 4A and 5N and 5A. If you find lack of continuity in any mode when making these checks, the switch is defective and should be replaced.

## SWITCH ASSEMBLY

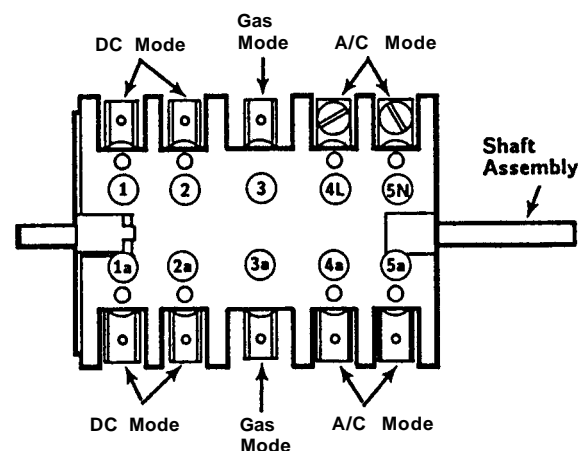

(67)  
Before an appliance can be sold to a recreational vehicle manufacturer it must be tested and approved by a nationally recognized testing laboratory for the specific end use intended. All Dometic refrigerators used in recreational vehicles have received this certification.



(68)  
If you require additional service assistance on the basic requirements for the cooling unit operation or the manual refrigeration, please refer to the diagnostic manual. For additional technical service assistance, contact the Technical Service Department at (219) 463-4858.



(69)  
You are an essential part of a team that contributes greatly to the successful future of the RV industry, your dealership and Dometic. Thank you for participating in the training program.

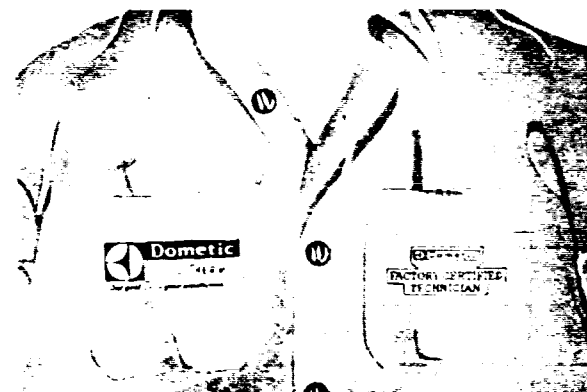



## Glossary of Terms

### MANUAL REFRIGERATION

1. ABSORBER: Section of the cooling unit where the hydrogen and ammonia vapor are intermixed in the absorber. Ammonia vapor returns to solution and the hydrogen returns to the evaporator.
2. BOILER: Section of the cooling unit where heat is applied. This is where the ammonia is partially separated from the water.
3. BY-PASS SCREW: Small brass screw located on any Dometic gas thermostat that regulates gas flow in the low flame mode. There are three common sizes of this screw: S-17-350 BTU, S-14-325 BTU, S-1 1-300 BTU.
4. F o u n d G A S / E L E C T R I C T H E R M O S T A T: Dometic m a n u a l refrigerators, this device is held in place with "O" ring seals in the gas line and replaces separate electric and LP gas thermostat controls. On the LP gas mode, full line pressure is directed through the thermostat to the burner until the thermostat senses that the refrigerator cabinet has reached proper cooling temperature. At that time an internal valve closes and redirects the gas flow through the by-pass screw. This reduces the amount of LP gas going to the burner assembly. The gas flow remains in this "by-pass" mode until the thermostat senses that the refrigerator cabinet needs more cooling. Again, the thermostat directs the LP gas flow through the thermostat at full line pressure until the cabinet temperature is sufficient. On the electric mode the internal mechanism breaks contact (continuity) when adequate cabinet temperature has been reached.
5. CONDENSER: Section of the cooling unit that cools the ammonia vapor into ammonia liquid.
6. COOLING UNIT: Self-contained, hermetically sealed set of steel coils where the refrigeration process takes place. The chemicals involved in the cooling process include hydrogen, ammonia, water and a rust inhibiting agent.
7. CUT-OFF VALVE (Shut-Off Valve): Valve where the incoming propane supply is attached. This valve is direct-coupled to the selector switch by means of a steel clip. When the selector switch is turned to the electric mode, the cut-off valve is automatically closed. When this same switch is turned to the LP gas mode, the electric circuit is also automatically interrupted.
8. EVAPORATION: A process that causes a liquid to turn into a vapor. Whenever evaporation takes place, heat is removed.
9. EVAPORATOR: Section of the cooling unit where the cooling effect is produced. Liquid ammonia evaporating in a hydrogen atmosphere takes place in the evaporator.
10. HEATING ELEMENTS: Elements that operate off either AC or DC voltage that create heat to the cooling unit.
11. IGNITER-REIGNITER: The igniter-reigniter, used on certain Dometic model refrigerators, operates on 12 volt current. On gas operation the igniter senses the resistance through the flame between the electrode and burner. When there is no flame at the burner, the resistance is high and the igniter begins sparking to light the burner. **As** soon as the flame is lit, the resistance between the electrode and burner drops and the igniter stops sparking. The resistance is monitored by the igniter, and if for any reason the flame goes out, the igniter begins sparking until the burner is lit. This insures that the flame will always be lit when desired. Each time the igniter-reigniter system sparks, a light will illuminate on the lower left front corner of the refrigerator.
12. LP. GAS PRESSURE: For the refrigerator to operate properly on LP gas, the gas pressure should be set at 11" water column pressure. NOTE: use the test port at the rear of the refrigerator to take this reading.

(Glossary of Terms . . . continued)

13. **ORIFICE (JET):** A small brass fitting that is mounted on the gas line just prior to the burner. This device incorporates a very small opening to greatly reduce gas flow to the burner. The orifice is cleaned by using an alcohol based solvent and allowing to air dry.
14. **PIEZO LIGHTER:** Self-contained lighter assembly that is used to generate a spark to light the refrigerator on LP gas. This unit contains a quantity of quartz crystals that when pushed or snapped, produce a spark. There are no serviceable parts on this device.
15. **SAFETY DEVICE:** An assembly of parts (safety valve, magnet and thermocouple) that shuts off the supply of LP gas to the burner assembly if the flame goes out for any reason. This is to ensure that a concentration of unburned gas does not accumulate in the refrigerator vent area.
16. **SELECTOR SWITCH:** This is also a circuit interrupter on the 12 volt DC, 120 volt AC and gas sides of operation on the refrigerator. When the customer selects either DC, AC or GAS operation, the selector switch directs electricity first to the thermostat and on to the heating element, or igniter-reigniter. When this switch is turned off, the AC or DC circuit is interrupted.
17. **SPIRAL BAFFLE:** Spiral metal device that is hung in the flue tube assembly of the cooling unit. The baffle causes the heat supplied by the gas burner to stay at the boiler assembly a longer period of time. This allows the absorption system to work as efficiently on LP gas as other heat sources.
18. **WATER COLUMN:** The pressure rating given to LP gas line pressure. Usually this pressure can be varied by adjusting the regulator on the LP supply tank. A manometer is the device used to test LP gas pressure.



## TYPES OF BLOCKAGE

To understand the absorption principle we have set up several refrigerators to inspect and diagnose. Carefully touch the absorber and boiler sections of each unit and record your findings. Proceed with caution as some of these units could be extremely HOT.

Listed below are three types of units you will be testing:

■ GOOD COOLING UNIT

Carefully touch the unit at the boiler box and the absorber area. These areas should be approximately the same temperature, regardless of the ambient temperature. The equal heat between the boiler and the absorber indicates the fluid circulation within the unit is good.

□ BLOCKAGE

One of the faults with a cooling unit is blockage. This can happen when the unit is operated off-level, or if too much heat has been applied to the boiler area. To the touch this unit will be extremely hot at the boiler with little warmth at the absorber. In other words, NO CIRCULATION.

■ LEAKER

This type of fault means the unit has lost its charge - it's known as a "leaker". To the touch this unit will be warm at the boiler and extremely hot at the absorber. In this condition we are still boiling ammonia but have no hydrogen for evaporation.

# CHANGING THE HINGE POSITION

MODELS: 2600,2602,2800,2802, 3600,3601,3800 & 3801

## WHEN CHANGING THE HINGE POSITION:

Insure that the door latch assembly operates properly after changing the hinge position from left to right, or vice-versa, with the following checks:

- The refrigerator door(s) opens and closes easily.
- The door gasket seals smoothly and completely on all sides.
- Slide the latch left to the locked position and try to open the door(s). The latch assembly should keep the door(s) from opening.

**NOTE:** A hard pull will release the door latch assembly and the door(s) will open. This is not a fault. (If an adjustment is required, repeat the above procedure to determine the effectiveness of the repair.)

**SMOOTH FIT,  
PROPER SEAL**

**SMOOTH FIT,  
PROPER SEAL**

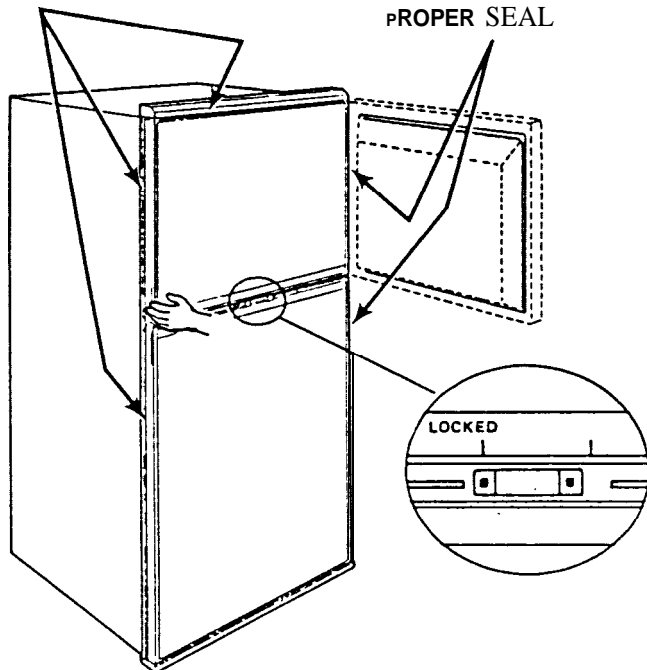

FIG. 1

If the door(s) open when the latch assembly is in the locked position, adjust the hinge/door assembly. Follow the outlined steps to complete this procedure:

- Open the door and remove the two (2) front decoration screws located underneath the upper hinge assemblies.
- Remove the front decoration by lifting the decoration upward.

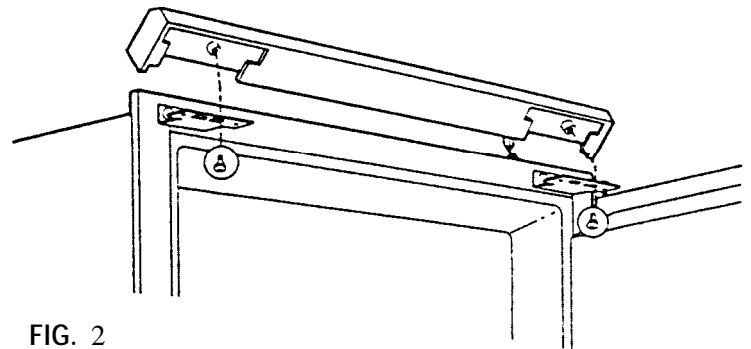

FIG. 2

- Loosen the screws that hold the upper hinge in place.
- Reorient the door so the catch retainer on the door will engage with the latch assembly. (Usually lowering the door will accomplish this.)

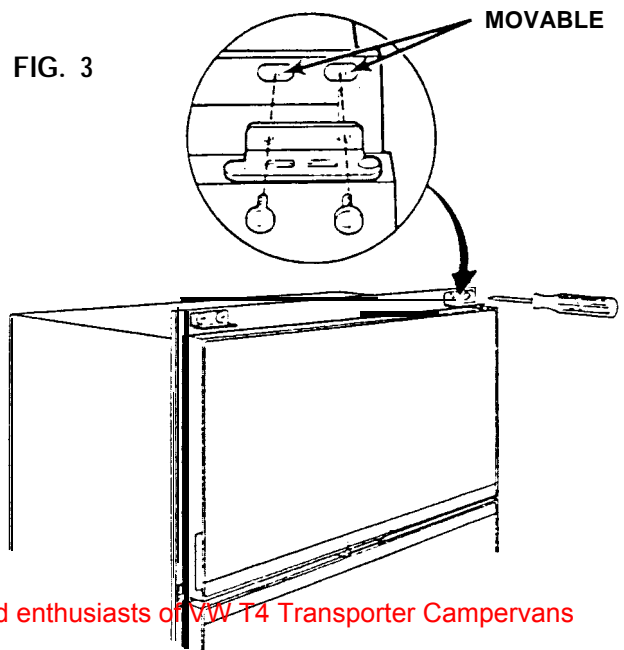

FIG. 3

5. Hold the door in its new position and carefully retighten the hinge screws, being careful not to change the hinge position.
6. Close the door and again determine if the latch is now operational.
7. If more adjustment of the door position is necessary, the center hinge screws may be loosened to reorient the door in the proper position.
8. Again retighten the hinge screws to allow the latch to operate properly.

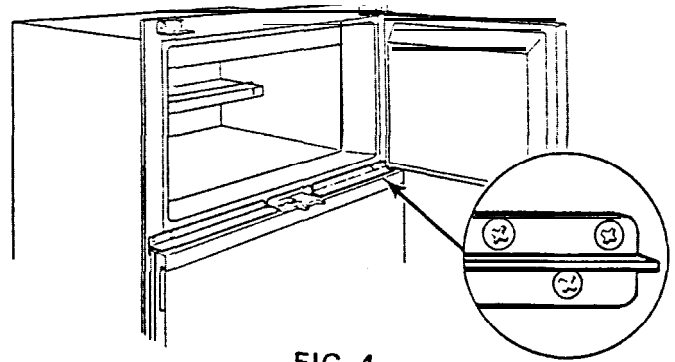

FIG. 4

### SPECIAL HINTS TO ADJUST DOOR

1. If there is a large distance between the lower door catch retainer and the latch, adjusting the hinge position still may not allow the latch to operate properly.

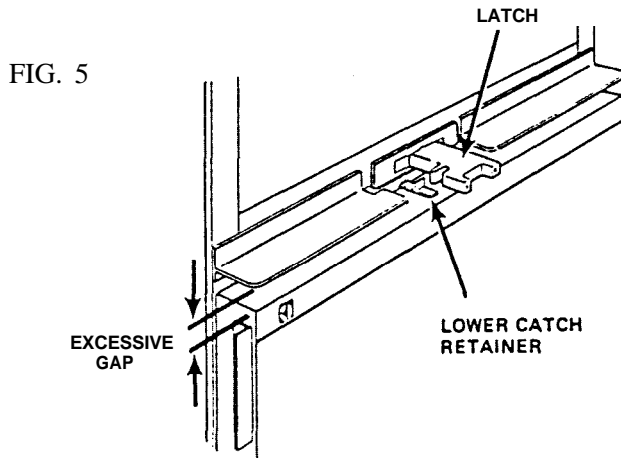

FIG. 5

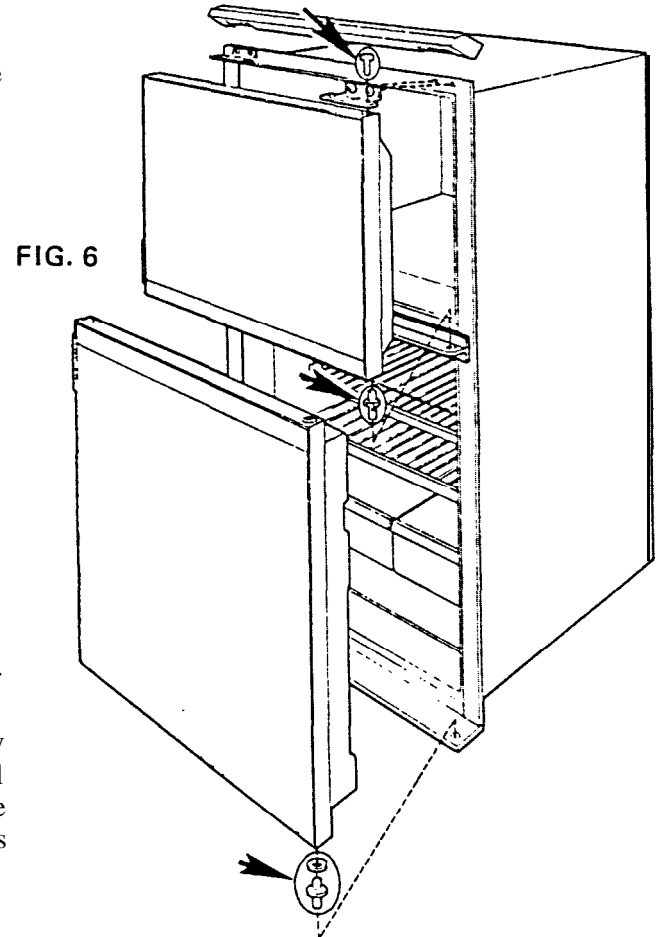

FIG. 6

2. Remove the upper, and if necessary, the center hinge pin(s). This allows you to remove the refrigerator door(s).
3. Place a metal, 1/4" flat washer (available at any hardware store) over the lower hinge pin and reinstall the door(s). This will raise the door to engage the latch assembly. (On very rare occasions two [2] washers may be required.)

If the latch assembly still will not engage, the base can be repositioned to reorient the door as follows:

1. Turn the refrigerator on its side to gain access to the four (4) base screws. Loosen all four (4) screws slightly.
2. Reposition the base so that the door catch retainer engages with the latch.
3. Retighten the base screws while holding the base in its new position.

FIG. 7

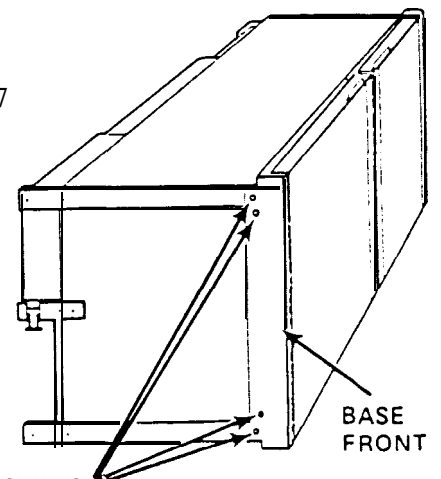

By following the above listed procedures you will be able to correct any door latching problems incurred when reversing the hinge position on your Dometic refrigerator.

If you have any questions concerning this procedure, contact our Technical Services Department at:

# PROCEDURE FOR CHANGING COOLING UNIT

The following categories have been established predicated on similarity of design and procedure for replacement of cooling units. Most Dometic refrigerators are covered in one (1) of these categories.

**SPECIAL NOTE:** After the cooling unit has been installed, the initial start-up time can be shortened by tilting the refrigerator from side to side and then from front to back before the refrigerator is turned on.

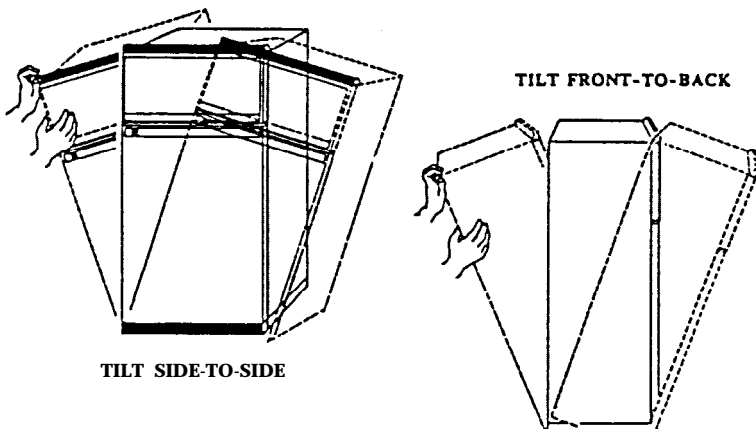

Run the refrigerator on a bench for 12 hours after the cooling unit has been installed (all food should be removed for testing).

FC140 Cooling Unit cannot be replaced

## A. Category #1

RM46	RM46 1	RM663	RM2500
RM360	RM660	RM2300	RM3500
RM460	RM661	RM2400	

### REMOVAL OF COOLING UNIT

1. Remove heater(s) from boiler case (FIG. A1).
2. Disconnect burner from chimney (FIG. A2).
3. Remove evaporator screws inside refrigerator and remove cooling flange (FIG. A3).
4. Remove screws holding clamp for capillary tube. Pull capillary gently out of plug (FIG. A3).
5. Remove screws holding unit from rear (FIG. A1).
6. Apply leverage as shown and pull out (FIG. A1).

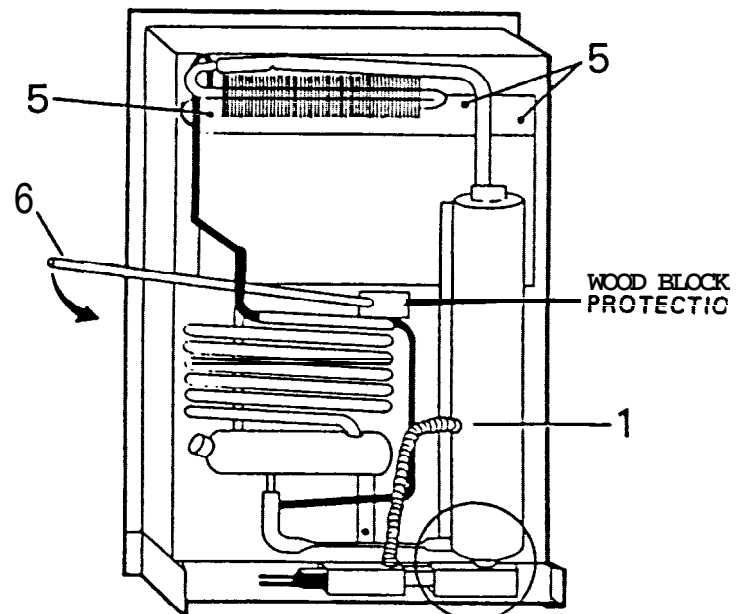

FIG. A1

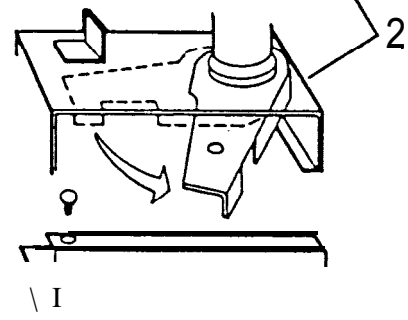

FIG. A2

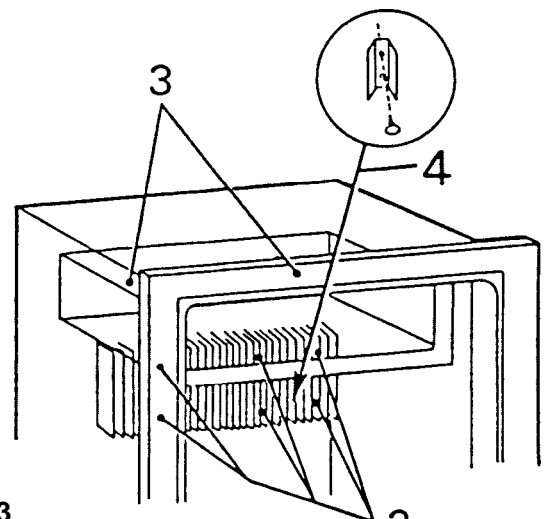
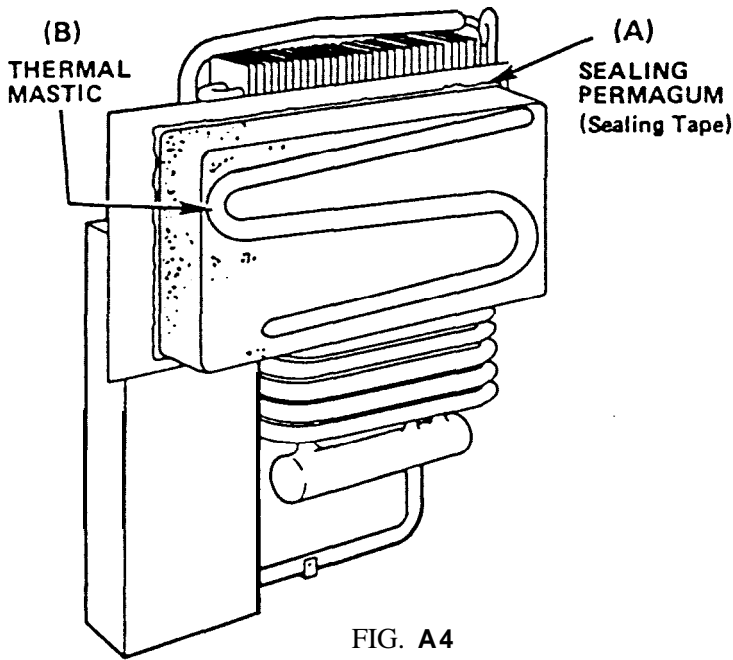

FIG. A3

INSTALL REPLACEMENT COOLING UNIT:

1. Trim the Styrofoam portion of the cooling unit if it does not go freely into the refrigerator.
2. Apply sealing permagum (sealing tape) on mounting plate (A; FIG. A4).
3. Apply thermal mastic *on* the evaporator coil (B; FIG. A4).
4. Tighten screws securely to obtain proper contact between the evaporator coil and evaporator flange; otherwise improper cabinet performance may result.
5. Install the heating element completely back into the pocket and plug in.
6. Reconnect burner assembly to chimney.
7. Reinstall capillary tube into proper position (FIG. A3).



4. Remove evaporator screws (FIG. B4).
5. Remove screws holding unit from rear (FIG. B1).
6. Cut tape holding plate (FIG. B1).
7. Apply leverage as shown and pull unit out (FIG. B ).

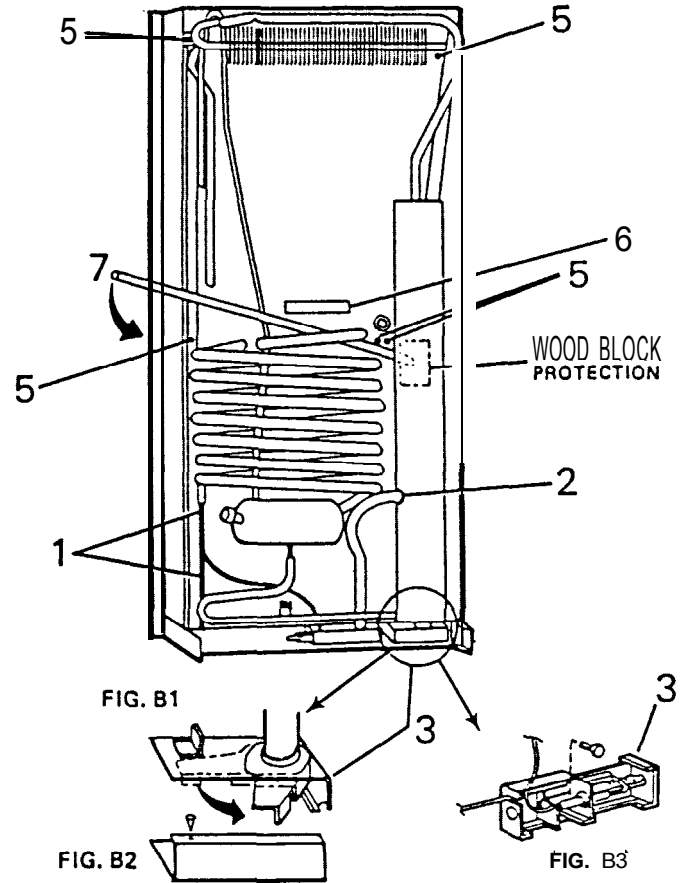

B. Category #2

RM100	RM763	RM1303	
RM760	RM1300	RM2600	RM3600
RM761	RM1301	RM2800	RM3800

REMOVAL OF COOLING UNIT:

1. Remove screw holding clamp for capillary tube. Pull capillary tube out gently and place aside (FIG. B1).
  - a. RM3600, RM3800 (FIG. B4)
2. Remove heater(s) from boiler case (FIG. B1).
3. Disconnect burner from chimney (FIG. B2 and B3).
  - a. RM2600, RM2800, RM3600, RM3800 (FIG. B3).

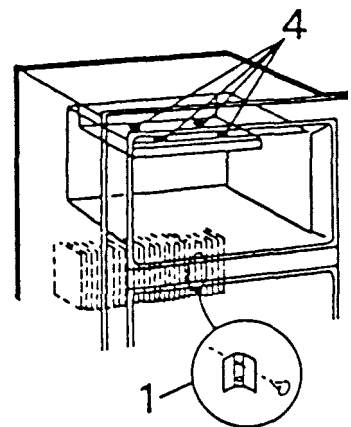

INSTALL REPLACEMENT COOLING UNIT:

1. Trim the Styrofoam portion of the cooling unit if it does not go freely into the refrigerator.

2. Apply sealing permagum (sealing tape) on mounting plate (A; FIG. B5).
3. Apply thermal mastic on the evaporator coil (B; FIG. B5).
4. Tighten screws securely to obtain proper contact between the evaporator coil and evaporator flange; otherwise improper cabinet performance may result.
5. Install the heater element completely back into pocket and **plug** in.
6. Reinstall capillary tube into proper position.
  - a. RM100, RM2600 & RM2800 will clamp to cooling flange. (FIG. B4)
  - b. RM760, RM761 & RM763 will extend into retainer tube approximately 31" (FIG. B1)
  - c. RM1300, RM1301 & RM1303 will extend into retainer tube approximately 36" (FIG. B1)
  - d. RM3600 & RM3800 have internal thermostat with capillary tube clamped to cooling flange (FIG. B4)
7. Reconnect the burner assembly to chimney.

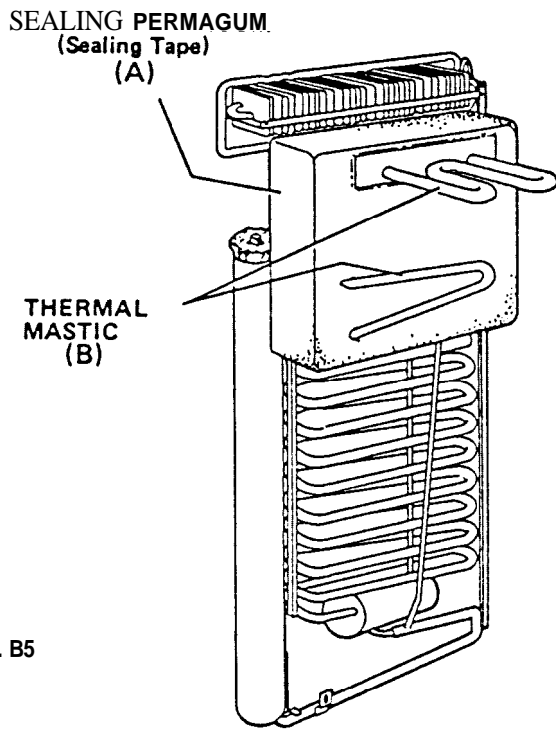

### C. Category #3

RC150 RC160

#### REMOVAL OF COOLING UNIT:

1. Remove screw and disconnect burner from chimney (FIG. C1).
2. Disconnect heater wires from terminal block (FIG. C1).
  - a. Remove heaters from boiler case (FIG. C1).

3. Remove screws holding unit from rear (FIG. C1).
4. Disconnect green grounding wire (FIG. C1).
5. Pull out on cooling flange to remove fr evaporator coil (FIG. C1).
6. Pull thermostat capillary tube out gently and move so that cooling unit will clear (FIG. C1).
7. Remove cooling unit by hinging out on right side (FIG. C1).

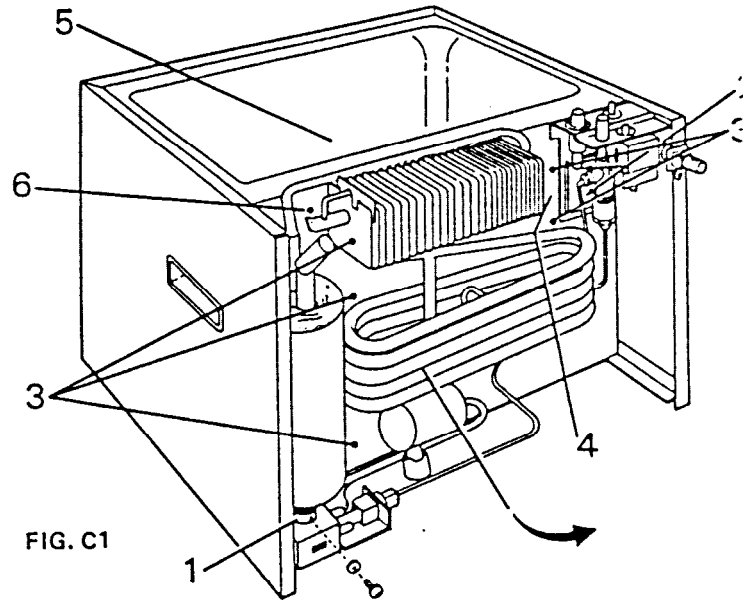

#### INSTALL REPLACEMENT COOLING UNIT:

1. Trim the Styrofoam portion of the cooling unit if it does not go freely into the refrigerator.
2. Apply sealing permagum (sealing tape) on window insulation (A; FIG. C2).
3. Apply thermal mastic on the evaporator coil (B; FIG. C2).
4. Tighten screws securely to obtain proper seal; otherwise improper cabinet performance may result.
5. Install the heat elements completely back into the pocket and attach to terminal block (FIG. C1).
6. Reconnect burner assembly to chimney (FIG. C1).
7. Reinstall capillary tube into proper position (FIG. C1).

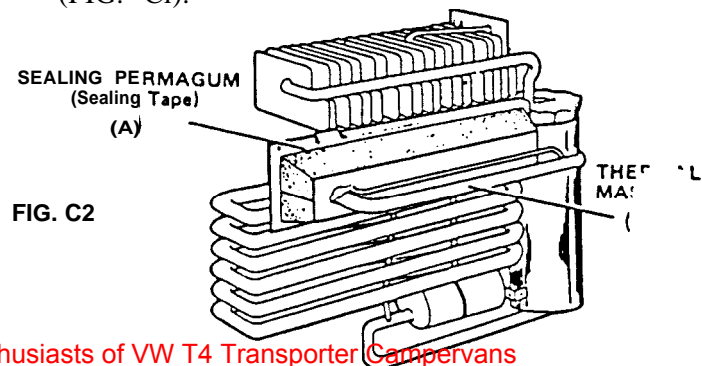

### D. Category #4

RM190

RM2190

RM2 192

#### REMOVAL OF COOLING UNIT:

1. Remove cover and flue tube, then disconnect burner from chimney (FIG. D1).
2. Remove heater(s) from boiler case (FIG. D1).
3. Remove screws and take out evaporator fins and shelf (FIG. D2).
4. Release holding clamp for thermostat capillary tube and pull tube out gently (FIG. D2).
5. Remove one (1) screw and bend two (2) tabs and then pull cooling unit out (FIG. D1).

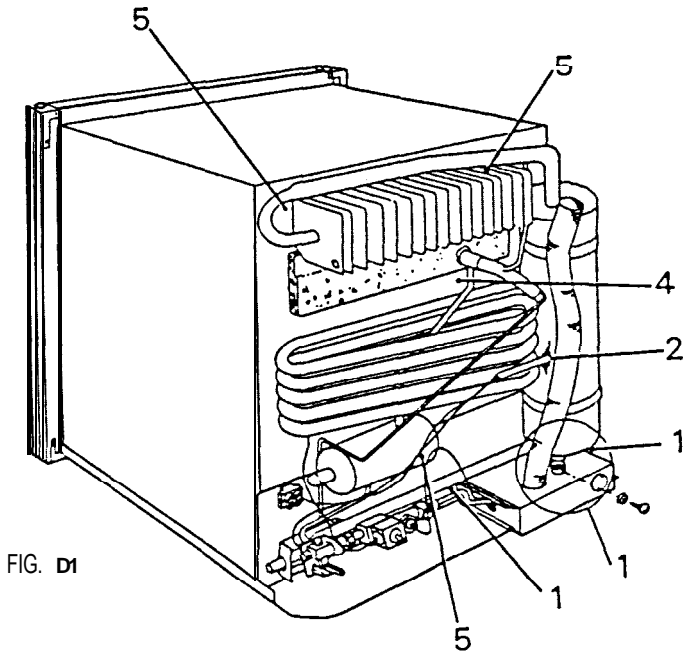

FIG. D1

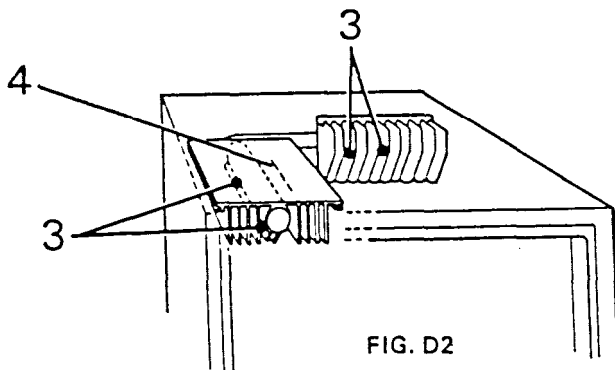

FIG. D2

#### INSTALL REPLACEMENT COOLING UNIT:

1. Trim the Styrofoam portion of the cooling unit if it does not go freely into the refrigerator.
2. Apply thermal mastic on the evaporator coil (B; FIG. D3).

3. Apply sealing permagum (sealing tape) on window insulation (A; FIG. D3).
4. Tighten screws securely to obtain proper seal.
5. Install the heating elements completely back into the pocket.
6. Reinstall capillary tube into proper position.
7. Reconnect burner assembly to chimney and replace cover.

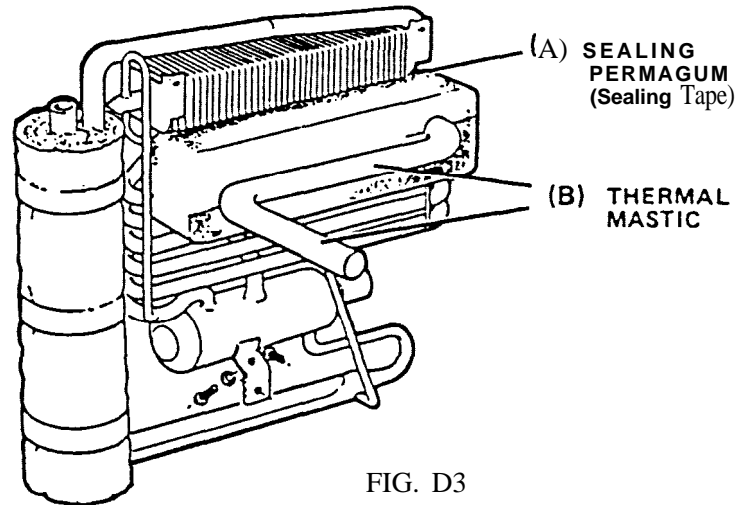

FIG. D3

### E. Category #5

RM211

#### REMOVAL OF COOLING UNIT:

1. Remove cover and disconnect burner from chimney (FIG. E1).
2. Remove heater from boiler case (FIG. E1).
3. Remove three (3) screws holding unit from rear (FIG. E 1).
4. Pull cooling unit part way out and then disconnect thermostat capillary tube and pull out (1; FIG. E2).
5. Complete removal of cooling unit.
6. Remove evaporator fins and shelf (2; FIG. E2).

#### INSTALL REPLACEMENT COOLING UNIT:

1. Apply thermal mastic on the evaporator coil (B; FIG. E2).
2. Install evaporator fins and shelf (FIG. E2).
3. Apply sealing permagum (sealing tape) on window insulation (A; FIG. E2).
4. Reinstall capillary tube into proper position (FIG. E2).
5. Tighten screws securely to obtain proper sealing.
6. Reconnect burner assembly to chimney and replace cover (FIG. E1).
7. Install the heating elements completely back into the pocket (FIG. E1).

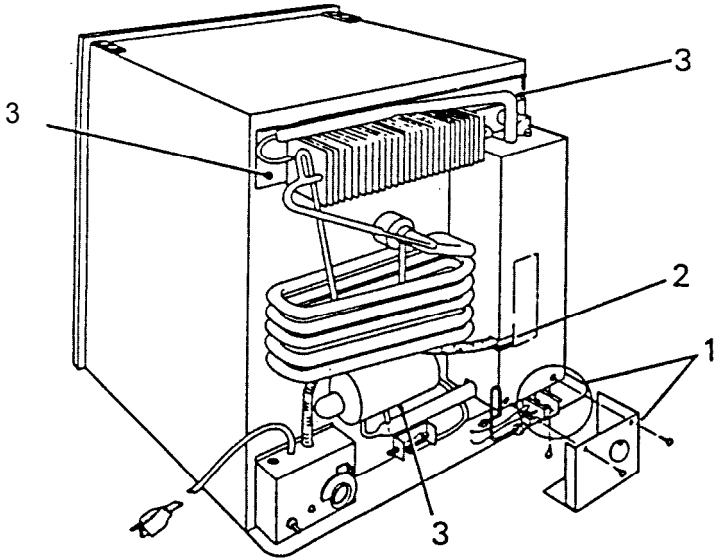

FIG. E1

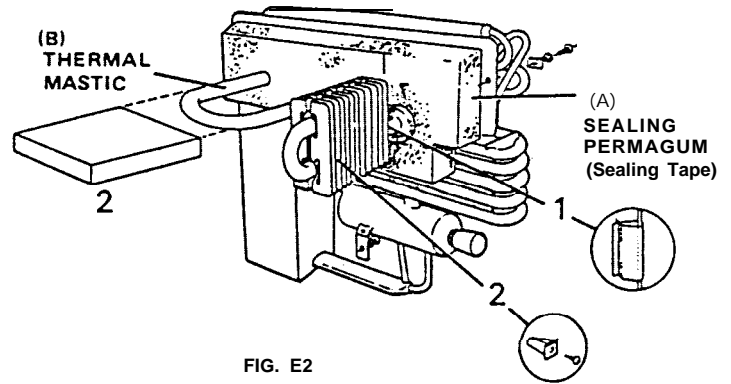

FIG. E2

## F. Category #6

RM75

RM76

RM77

### REMOVAL OF COOLING UNIT:

1. Remove burner protection cover and remove burner from chimney (FIG. F1).
2. Remove heaters from boiler case (FIG. F1).
3. Remove evaporator screws (FIG. F2).
3. Remove two (2) screws holding clamp for thermostat capillary tube. Pull capillary tube out gently (FIG. F2).
5. Remove ten (10) screws holding unit from rear (FIG. F1).
6. Pull out on cooling unit and remove.

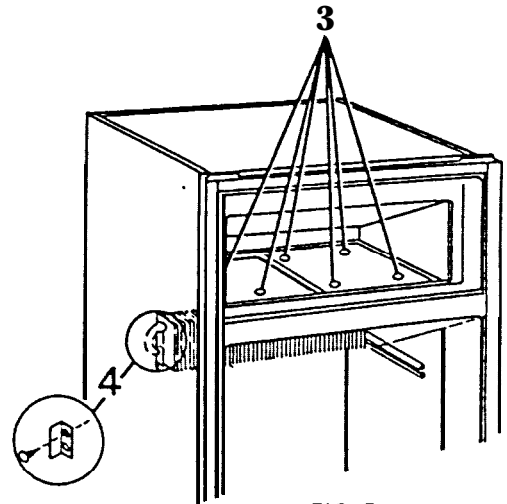

FIG. F2

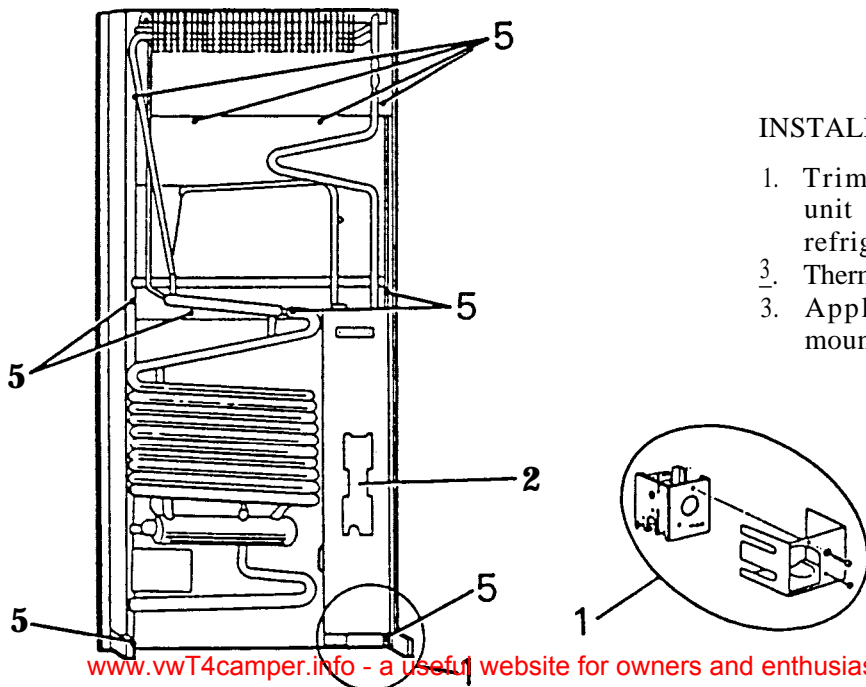

FIG. F1

### INSTALL REPLACEMENT COOLING UNIT:

1. Trim the Styrofoam portion of the cooling unit if it does not go freely into the refrigerator.
3. Thermal mastic is not used on these units.
3. Apply sealing permagum (sealing tape) on mounting plate (FIG. F3).



4. Tighten screws securely to obtain proper seal.
5. Install heating elements completely back into the pocket and plug in (FIG. F1).
6. Reconnect burner assembly to chimney (FIG. F1).
7. Reinstall capillary tube into proper position (FIG. F2).

5. Tighten screws securely to obtain proper seal.
6. Install the heating elements completely back into the pocket.
7. Reconnect burner assembly to chimney and replace cover.

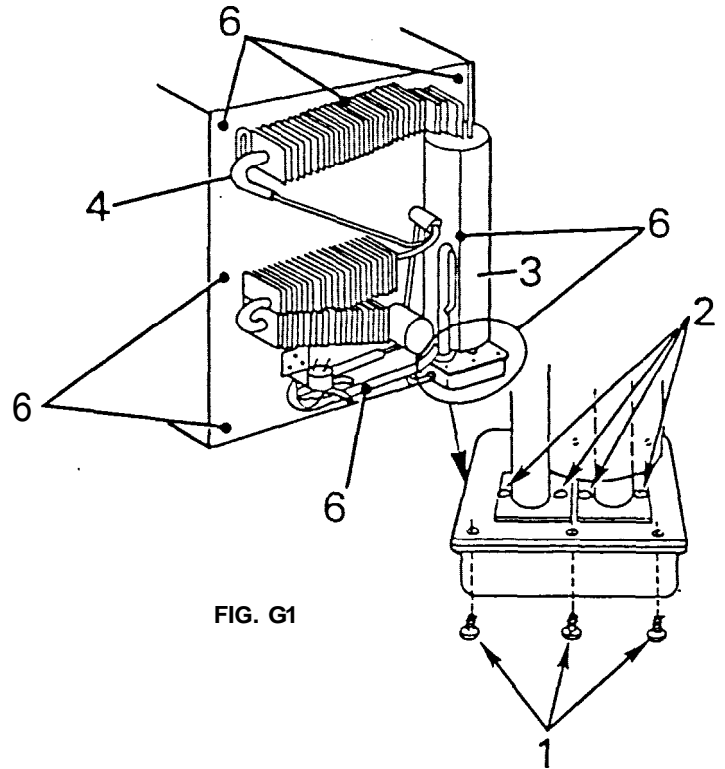
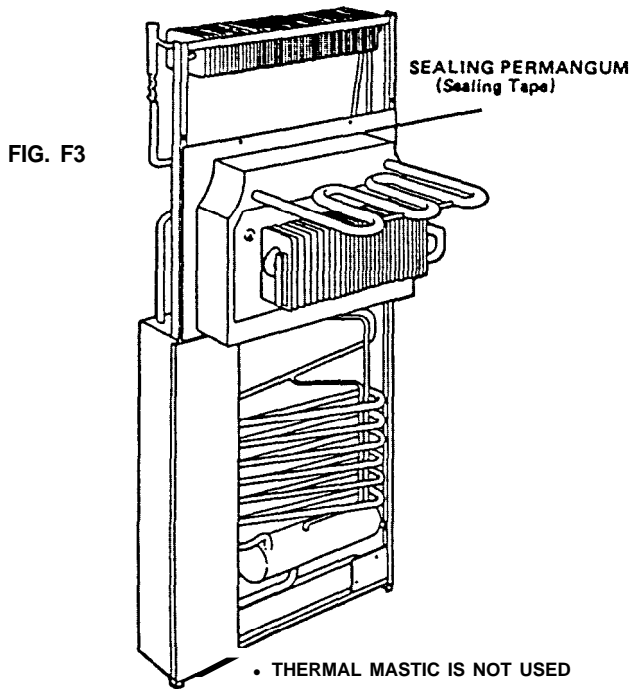

### G. Category #7

RM182

#### REMOVAL OF COOLING UNIT:

1. Remove six (6) screws from burner cover (FIG. G1).
2. Disconnect burner from chimney (4 screws) (FIG. G1).
3. Remove heaters from boiler case (FIG. G1).
4. Carefully pull out thermostat capillary tube (FIG. G1).
5. Remove two (2) evaporator screws and take out ice tray support (FIG. G2).
6. Remove eight (8) screws holding unit from rear (FIG. G1).

Remove two (2) screws holding gas line gasket (FIG. G1).

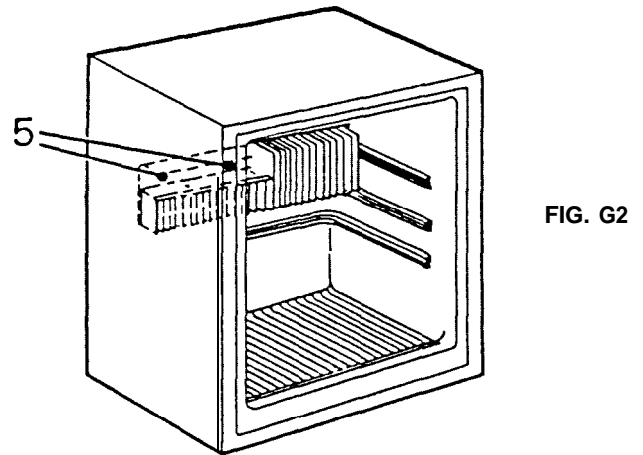

#### INSTALL REPLACEMENT COOLING UNIT:

1. Trim the Styrofoam portion of the cooling unit if it does not go freely into the refrigerator.
2. Apply thermal mastic on the evaporator coil (B; FIG. G3).
3. Apply sealing permagum (sealing tape) (A; FIG. G3).
4. Reinstall thermostat capillary tube.

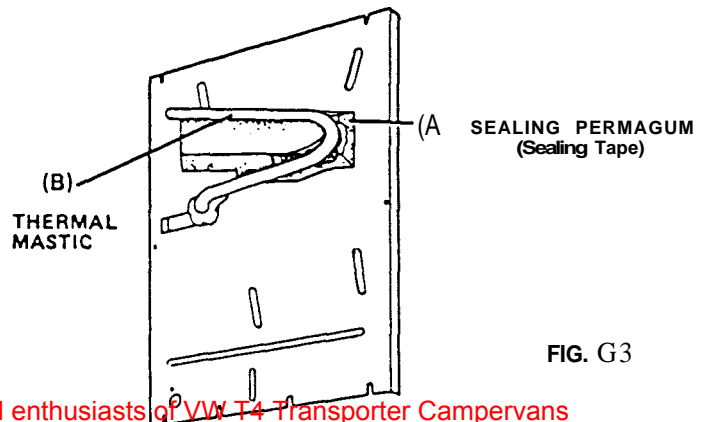

# Before You Change That Cooling Unit

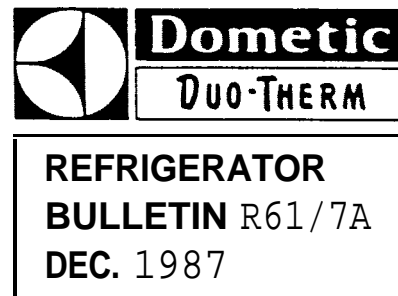

## PART I. PROPER DIAGNOSIS

Cooling units are sometimes diagnosed as being defective when the actual problem is something else. Cooling units are expensive to replace, so it is important to make the correct diagnosis. By using the proper test procedures, you can eliminate all other possibilities before condemning the cooling unit.

Any time the cooling unit is a possible suspect, use the following step-by-step procedure before replacing it.

### A. PRELIMINARY CHECKS

1. Check for an ammonia smell around the cooling unit and inside the refrigerator. This could indicate a possible refrigerant leak. Check for any deposits of yellow powder on the tubing which will sometimes form around the area of a leak. NOTE: A yellow deposit in the area of the fill valve could be due to splashing of refrigerant during manufacture, and would not indicate a leak.
2. Determine if the refrigerator works on one heat source but not another by testing it in the alternate modes. Also, ask the customer if he gets better cooling results from one energy source than another. If this is true, it indicates the problem is NOT in the cooling unit.
3. Make sure the refrigerator is level. Sometimes the vehicle is level but the refrigerator is not, due to improper installation. Place a level on the bottom of the freezer compartment and check side-to-side and front-to-back levels (see FIG. A1). Use a mirror, if necessary to read the level.
4. Carefully check door gaskets for proper seal. A leaking gasket can allow enough warm air inside the refrigerator to overcome most of the cooling being produced.

For a simple method to check gaskets, close the door on a dollar bill, then pull the dollar bill out. If no resistance is felt, the gasket is not sealing properly. This should be done on all four sides of the door.

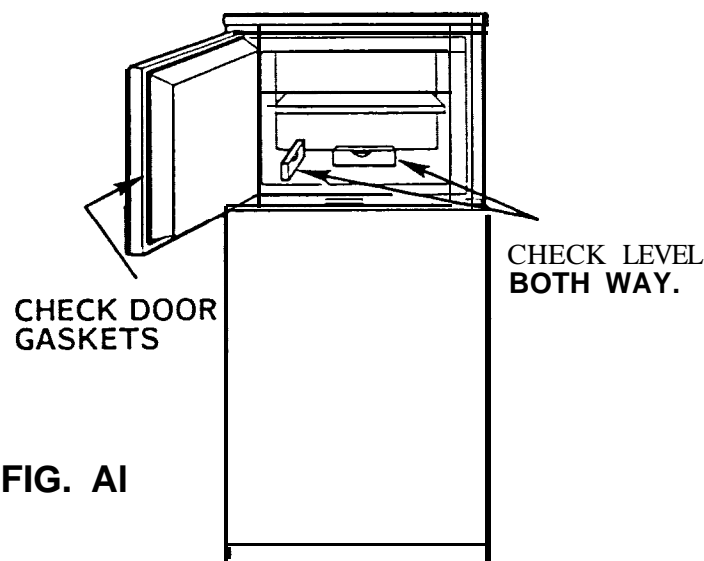

5. Check the venting system to insure that ample air flow is provided at the back of the refrigerator.
  - A. Check for, and remove, any restrictions in the vents, such as filters installed by the customer, bird nests in the roof vent, or smashed louvers in the wall vents (see FIG. A2).
  - B. Make sure the correct roof vent has been installed. Larger models such as RM100, 760, 761, 1300, 1303, 2600, 2800, 2802, 3600, 3800, 3802 and 4801, require a 5" X 24" opening for the roof vent. Smaller models will also use the 5" X 24" roof opening. To check this, measure the actual opening in the roof - DO NOT measure the roof vent itself. See FIG. A2.

Also, make sure the distance from the bottom of the refrigerator to the roof vent is at least the minimum dimension given in the Installation Instructions for each model. See FIG. A2.

FIG. A2

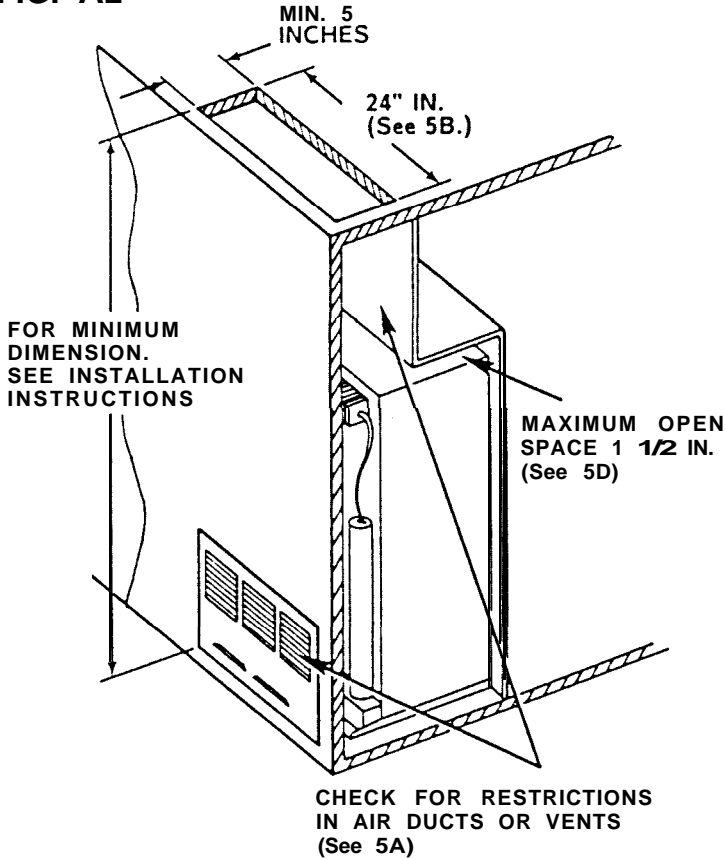

C. Some smaller models may be installed with two side wall vents instead of using a roof vent. For this type of installation make sure the top of the upper vent is the correct distance above the refrigerator. See FIG. A3. The minimum dimension for this measurement is listed in the Installation Instructions for each model.

FIG. A3

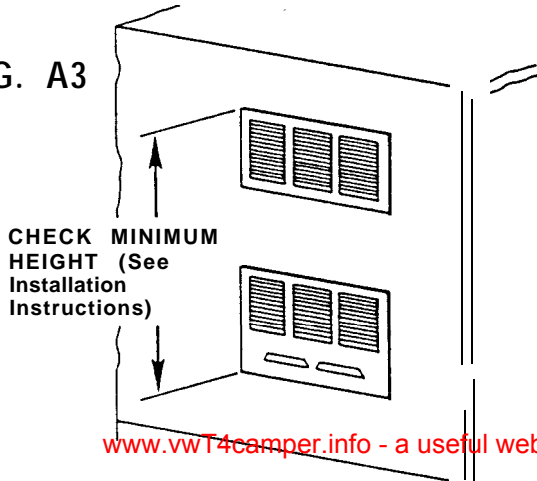

D. Check the open space above the refrigerator. If this space is 1 1/2 inches or more it must be blocked off to prevent hot air from being trapped above the refrigerator. See FIG. A2.

If venting is suspected as a problem, run the performance test described below with the refrigerator installed, then run the same test with the refrigerator removed. If there is a definite improvement in performance, a venting problem is indicated. Also, see Section B. PERFORMANCE TEST, Item 9.

SPECIAL VENTING FOR DIRECT-VENT MODELS RM182, 215, 2192

These models are designed to be installed in small vans and are usually placed in a cabinet that is not open to the outside of the vehicle. This means that air from within the vehicle must be used to cool the condenser.

Customers with this type of installation must be made aware that the vehicle interior must be kept from getting too hot. If the vehicle is left parked in the sun, with all doors and windows closed, the inside temperature can quickly exceed 100 degrees, and the cooling process will slow down or stop completely.

REAR VIEW OF REFRIGERATOR

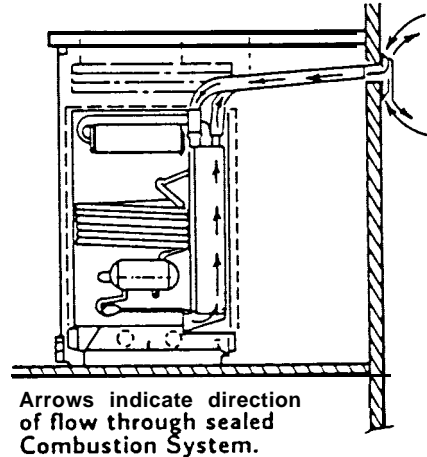

Alternative positions

SIDE VIEW OF REF. for OR upper ventilator

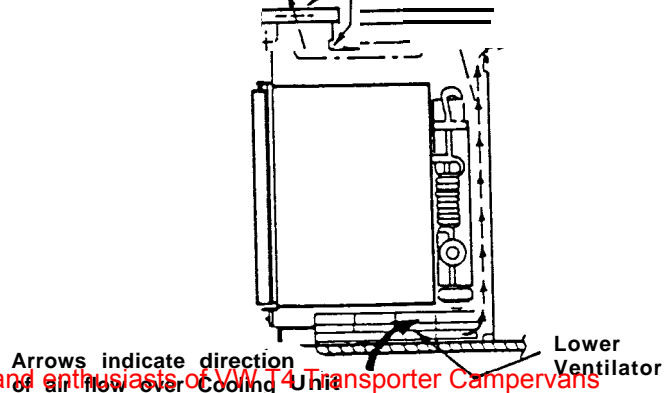

**B. PERFORMANCE TEST**

1. First perform all the preliminary checks described previously.
3. Remove all food from the refrigerator and place all controls in the OFF position.
3. Place an accurate thermometer in an ice cube tray, half filled with water, and place the tray in the center of the lower food storage compartment. NOTE: If a remote-reading thermometer is used (allowing temperature readings without opening the door) the tray of water is not required.
4. Make sure the AC heating element is the correct wattage for the model being tested, and that the resistance reading is correct. (See "Checking Resistance of a Heating Element" below.)

Connect 120 volt AC power directly to the heating element leads (make sure the leads are not connected to the refrigerator circuit), then check the voltage at the element with a volt meter. Reading must show at least 115 volts.

5. After two hours of operation, check the temperature on the back of the cooling unit with your hand, at the locations shown.

**FIG. B1**

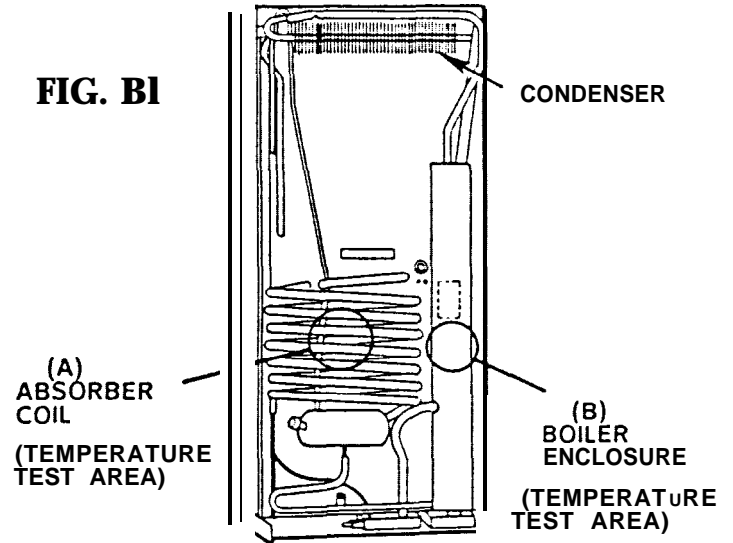

Under normal operation the temperature at the absorber coils (A) and the boiler (B) should be approximately the same. If the temperature at the absorber coils (A) is much hotter it indicates loss of refrigerant and the cooling unit must be replaced. If the temperature at the boiler (B) is very hot and the absorber coils (A) are cool it indicates that the refrigerant is not circulating properly. This could indicate:

**CHECKING RESISTANCE OF A HEATING ELEMENT**

A simple test to check a heating element is to measure the resistance through the element with an ohmmeter. The correct resistance, in ohms, can be calculated if the wattage and voltage ratings are known. (These ratings are stamped on all Dometic heating elements.)

Use this Formula:

$$\text{Volts} \div (\text{Watts} \div \text{Volts}) = \text{Ohms}$$

Example:

Heating element rated 135 Watts at 110 Volts.

$$110 \div (135 \div 110) \text{ or,}$$

$$110 \div 1.23 = 89.4 \text{ ohms}$$

The ohm reading should be within 10% of this figure, or between 80.46 and 98.34 ohms. Use the lowest setting on the ohmmeter which will give an accurate reading.

When testing a 12 volt heating element, a very accurate ohmmeter must be used because of the very low readings that will be found. For example, a 200 watt element will have a reading of .72 ohms (less than 1 ohm).

**A.** Liquid trapped in the evaporator sections, caused by out-of-level operation for a period of time. Resetting the refrigerator to a level position will not necessarily correct the problem as liquid can remain trapped even after level is corrected. Shut off the heat source and let the system cool down, then re-start it and observe the temperatures at A and B again after several hours. If the same condition exists it could indicate:

**B.** A permanent blockage within the boiler pump tube, caused by too much heat applied to the burner (oversized orifice or heating element) or prolonged operation of the unit when out-of-level or with restricted ventilation. This type of blockage consists of hard deposits inside the boiler pump tube. This condition is not repairable and the cooling unit must be replaced.

NOTE: The cooling units currently being used are specially designed to prevent overheating of the boiler tube even when operated out-of-level. This special design can be identified by the round insulation box around the boiler, rather than the square-cornered box used on older units.

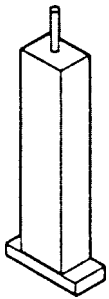

**Older Style  
Boiler Enclosure**

**FIG. B2**

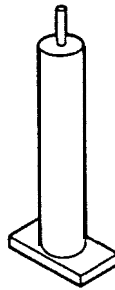

**Current Style  
Boiler Enclosure**

Blockage symptoms on the newer cooling units almost always, indicate trapped liquid in the evaporator, which can be corrected by proper leveling and allowing the cooling unit to cool off before restarting.

6. If the temperatures are satisfactory in Step 5, continue operating the unit, with power directly to the heating element, for a total of 10-12 hours. The doors must be kept closed for this entire period.
7. If the temperature is within the previously mentioned guidelines the problem is not in the cooling unit. See Section **II. OTHER CAUSES** for additional items that could be causing a loss of cooling.
8. If the temperature in the food compartment is higher than the acceptable limit, the cooling unit is probably defective. If you are still in question as to the performance of the cooling unit, please contact our Technical Service Department (219) 463-4858. See the next paragraph before changing the cooling unit.
9. The importance of adequate air flow across the cooling unit cannot be emphasized too much. A minor restriction in the venting system will not create a problem on cooler days - the available air flow will still provide adequate cooling due to the lower temperature. However, on a hot day (90" or more) even a minor restriction will cause overheating of the cooling unit and the cooling process will slow down or stop.

## ■ ONE LASTCHECK ■

If the previously mentioned test was performed in air temperatures above 90°, and the temperature in the refrigerator is above the acceptable ranges, it may indicate a restricted air flow. To make sure there is no problem with the venting system repeat the performance test with the refrigerator removed from its installed location and placed on the floor, or in your service shop. If the second test indicates satisfactory performance, re-check the venting and installation.

## PART II. OTHER CAUSES FOR LOSS OF COOLING

If the previously mentioned performance test shows that the refrigerator is working satisfactorily, and the customer still experiences loss of cooling, the following items need to be considered:

1. Make sure the customer is using the refrigerator properly. The cooling capacity of the absorption refrigerator is usually much lower than the refrigerator the customer has in his home, so the customer should be advised to follow the instructions for proper use in his Owner's Manual.
  - A. Start the refrigerator the day before it is to be filled with food.
  - B. When the refrigerator is being filled when preparing for a trip, the food should be pre-cooled, and frozen foods should be pre-frozen, before placing them in the refrigerator. Ice making should be avoided until the refrigerator has cooled the lower compartment to the desired temperature.
  - C. Air circulation within the food compartment is important for proper cooling. DO NOT place paper on the shelves or over-fill the compartment with large cartons, etc.
  - D. Do not put hot food in the refrigerator. Allow it to cool in room air first.

# REFRIGERATOR TECHNICAL DATA

REFRIGERATOR  
BULLETIN 28  
Rev. Feb. 1989

Model No.	Cooling Unit Part No.	Orifice Size & Part No.	Heater Element Specs.		A/C Amps	OHMs Resistance	DC AMPS
			Watt/Volts	Part No.			
FC140	-----	32 (2960082119)	160/120	2960343123	1.3	92	---
FC140			160/12	2960342117			13.3
RA1302	9286169009	58 (2007419217)	275/220	0173742024	1.25	176	---
RAK1 00	9286111001	Kerosene	----	-----	----	----	----
RAK1302	9286179008	Kerosene	-----	-----	----	----	----
• RC15	2922000000	-----	65/120-12	2922372020	.54	222	5.4
RC65G	N/A	50 (0061667002)	-----	-----	----	----	----
RC65K	N/A	Kerosene	-----	-----	----	----	----
• RC150	2922302001	-----	65/120-12	2922372020	.54	222	5.4
• RC150A	2922471020	-----	65/120-12	2922372020	.54	222	5.4
RC150TEG	2942312022	(2928787031)	75/120	2929491567	.63	190	---
RC 150TEG			85/12	2929375042			7.1
• RC152	2 9 2 2 4 4 1 0 1 5	-----	65/120-12	2922372020	.54	222	5.4
RC160E	2942312022	(2928787031)	75/120	2929491567	.54	222	---
RC 160E			85/12	2929375042	.63	190	7.1
RC160TEG	2942312121	(2928787031)	75/120	2929491567	.63	190	---
RC 160TEG			85/12	2929375042			7.1
• M52	N/A	-----	225/120	0170679013	1.9	63	---
• M70	N/A	-----	225/120	0173074014	1.9	63	---
* RM18	2922034000	-----	65/120-12	2922372020	.54	222	5.4
RM23,24	9282571000	29 (2890039106)	95/120-12	2901943000	.79	152	7.9
* RM36	9282711002	43 (2002660161)	125/120	0173711011	1.0	120	---
* RM36C	9282711002	43 (2002660161)	125/120	0173711011	1.0	120	---
* RM36D	9282711002	43 (2002660161)	125/120	0173711011	1.0	120	---
RM36E	9282711002	38 (2002660146)	135/120	0173718016	1.1	109	---
RM36E			135/12	0173723016			11.3
• RM45,46,47	9283171008	51 (2002660179)	150/120	0173713017	1.3	92	---
• RM45,46,47			135/120-12	0173708009			11.3
RM46E	9283191006	43 (2002660161)	135/120	0173718016	1.1	109	---
RM46E			135/12	0173723016			11.3
• RM60,66	9283521004	52 (2002660187)	150/120	0173713017	1.3	92	---
• RM60,66			150/12	0173709007			12.5
RM66E	9283571009	52 (2002660187)	160/120	0173719014	1.3	92	---
RM66E			160/12	0173724014			13.3
RM66F	9283599000	51 (2002660179)	160/120	0173719014	1.3	92	---
RM66F			160/12	0173724014			13.3
* RM67	928352 1004	52 (2002660187)	150/120	0173713017	1.3	92	---
• RM67			150/120-12	0173709007			12.5
RM67D	9283521004	52 (2002660187)	175/120	0173715012	1.5	80	---
RM67D			150/120-12	0173709007	1.3	92	12.5
• RM67D	9283521004	52 (2002660187)	150/120	0173713017	1.3	92	---
• RM75,76,77,76D	9285134004	53 (2002660195)	225/120	0173074014	1.9	63	---
• RM100	9286109005	58 (2002660211)	275/120	0173720012	2.3	52	---
• RM100			275/12	3800368031			22.9
RM182	2929302004	24 (2928787049)	85/120-12	2929430003	.71	169	7.1
RM182B	2929302053	24 (2928787506)	85/120	2929374045	.71	169	---
RM182B			85/12	2929375042			7.1
RM190	9281 152000	F (2902540059)	95/12	2902192106			7.9
• RM211	9282740010	4 (2901860010)	95/120-12	2901943000	.79	152	7.9
• RM211B	19282743005	4 (2901860010)	95/120-12	2901943000	.79	152	7.9
RM215	19282761000	J (2902540075)	95/12	2902192125			7.9

[www.vwT4camper.info](http://www.vwT4camper.info) - a useful website for owners and enthusiasts of VW T4 Transporter Campervans

• Models that use brass heating elements approximately 3/4" in diameter.

Model No.	Cooling Unit Part No.	Orifice Size & Part No.	Heater Element Specs.		A/C Amps	OHMs Resistance	DC AMPS
			Watt/Volts	Part No.			
RM360,361	9283349000	32 (2007419134)	150/120	0173734013	1.3	92	---
RM360,361			125/120-12	0173735010	1.0	120	10.4
RM460,461	9283359009	39 (2007419159)	160/120	0173756016	1.3	92	---
RM460,461			125/120-12	0173735010	1.0	120	10.4
RM660,661	9283609007	52 (2007419183)	175/120	0173738014	1.5	80	---
RM660,661			175/12	0173739012			14.6
RM663	9283609007	52 (2007419183)	210/120	0173738048	1.8	67	---
RM663			175/12	0173739020			14.6
RM760,761	9285319001	53 (2007419191)	250/120	0173740010	2.1	57	---
RM760,761			250/12	0173741018			20.8
RM763	9285319001	53 (2007419191)	295/120	0173740044	2.5	48	---
RM763			250/12	0173741026			20.8
RM1300,1301	9286169009	58 (2007419217)	325/120	0173742016	2.7	44	---
RM1300,1301			275/12	0173743014			22.9
RM1303	9286169009	58 (2007419217)	325/120	0173742057	2.7	44	---
RM1303			275/12	0173743022			22.9
RM2150	2904377005	F (2902540059)	95/12	2902192108	---	---	7.9
RM2190	2904377005	F (2902540059)	95/12	2902192108	---	---	7.9
RM2192	2904433006	F (2902540059)	95/120	2903296024	.79	152	---
RM2192			95/12	2902192125			7.9
* RM2200A	9282743013	4 (2901860010)	95/120-12	2901943000	.79	152	7.9
RM2201	2904586019	F (2902540059)	95/12	2902192125	---	---	7.9
RM2300	9283349000	39 (2007419159)	160/120	0173756016	1.3	92	---
RM2300			125/120-12	0173735010	1.0	120	10.4
RM2301	9283349000	39 (2007419159)	160/120	0173756016	1.3	92	---
RM2400	9283359009	39 (2007419159)	160/120	0173756016	1.3	92	---
RM2400			125/120-12	0173735010	1.0	120	10.4
RM2401	9283359009	39 (2007419159)	160/120	01737756016	1.3	92	---
RM2401			125/120-12	0173735010	1.0	120	10.4
RM2500	9283609007	43 (2007419167)	175/120	0173738014	1.5	80	---
RM2500			175/12	0173739012			14.6
RM2501	9283609007	43 (2007419167)	175/120	0173738014	1.5	80	---
RM2501			175/12	0173739012			14.6
RM2600	2934801099	53 (2007419191)	295/120	0173754011	2.5	48	---
RM2601	2934801099	53 (2007419191)	295/120	0173754011	2.5	48	---
RM2602	2934801099	53 (2007419191)	295/120	0173754011	2.5	48	---
RM2603	2934801099	53 (2007419191)	295/120	0173754011	2.5	48	---
RM2604	2934803996	53 (2007419191)	295/120	0173754011	2.5	48	---
RM2604			215/12	0173757014			17.9
RM2800	2934901097	58 (2007419217)	325/120	0173742016	2.7	44	---
RM2801	2934901097	58 (2007419217)	325/120	0173742016	2.7	44	---
RM2801			215/12	0173757014			17.9
RM2802	2934901097	58 (2007419217)	325/120	0173742016	2.7	44	---
RM2803	2934901097	58 (2007419217)	325/120	0173742016	2.7	44	---
RM2804	2934903994	58 (2007419217)	325/120	0173742016	2.7	44	---
RM2804			215/12	0173757014			17.9
RM3500	2934701091	39 (2007419159)	185/120	0173738063	1.5	80	---
RM3500			175/12	0173739038			14.6
RM3501	2934701091	39 (2007419159)	185/120	0173738063	1.5	80	---
RM3501			175/12	0173739038			14.6
RM3600	2934801099	53 (2007419191)	295/120	0173754045	2.5	48	---
RM3600			250/12	0173755026			20.8
RM3601	2934801099	53 (2007419191)	295/120	0173754045	2.5	48	---
<b>RM601</b>			215/12	<b>0173757022</b>			17.9
<b>RM604</b>	<b>2934803996</b>	<b>53 (2007419191)</b>	295/120	<b>0173754045</b>	2.5	<b>48</b>	---
RM3604			215/12	<b>0173757022</b>			17.9
<b>RM800</b>	<b>2934901097</b>	<b>58 (2007419217)</b>	325/120	<b>0173742081</b>	2.7	<b>44</b>	---

[www.vwT4camper.info](http://www.vwT4camper.info) - a useful website for owners and enthusiasts of VW T4 Transporter Campervans

• Models that use brass heating elements approximately 3/4" in diameter.

Model No.	Cooling Unit Part No.	Orifice Size & Part No.	Heater Element Specs.		A/C Amps	OHMs Resistance	DC AMPS
			Watt/Volts	Part No.			
RM3800			275/12	0173743030			22.9
RM3801	2934901097	58 (2007419217)	325/120	0173742081	2.7	44	- - -
RM3801			215/12	0173757022			17.9
RM3804	2934903994	58 (2007419217)	325/120	0173742081	2.7	44	- - -
RM3804			215/12	0173757022			17.9
RM4801	2934902095	58 (2007419217)	325/120	0173742081	2.7	44	- - -
RM4801			215/12	0173757022			17.9

- Models that use brass heating elements approximately 3/4" in diameter.

**NOTE: The formula for calculating amps & OHMs:**

$$\text{Watts} \div \text{Volts (120/12)} = \text{AMPS}$$

$$\text{Volts (120)} \div \text{Amps} = \text{OHMs}$$



Replacement of cooling units in RM760.

Cooling unit **531A** will replace 530A in production and service.

When installing **531A** as replacement for 530A three new holes should be drilled in the cooling flange.

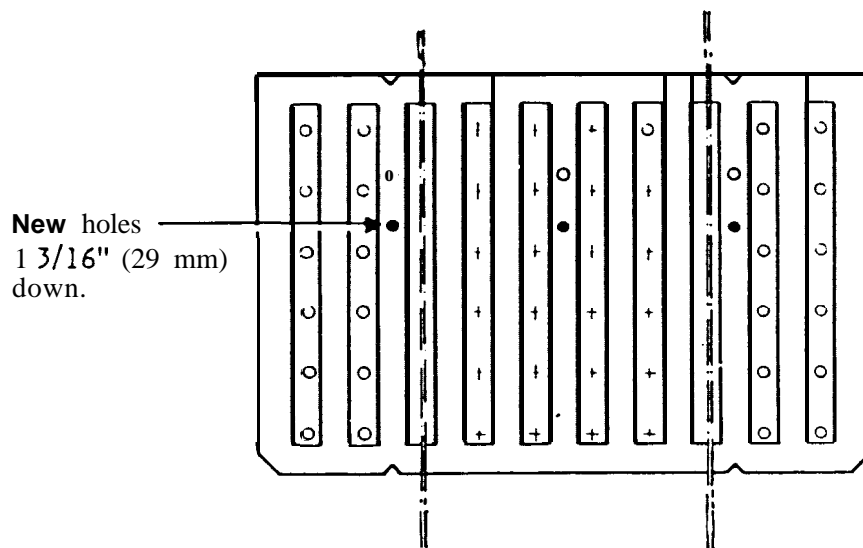

Furthermore the hole for the air channel (no longer necessary) in the burner box should be covered by a piece of aluminium tape (No combustible material must be used).

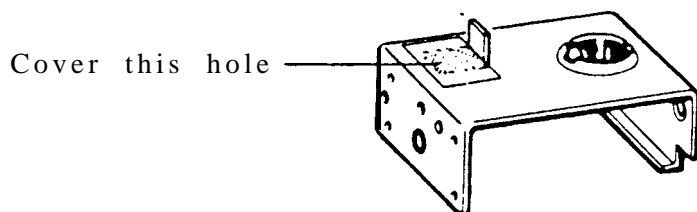



# Dometic

REFRIGERATOR BULLETIN  
REVISED AUGUST, 1984 #38

## CROSS REFERENCE OF REFRIGERATORS MANUFACTURED BY A.B. ELECTROLUX AND DOMETICARE PROCEDURE CHANGES

SUBJECT: Dometicare Procedure

An out of warranty cooling unit purchased from Dometic for installation on an Instamatic, Magic Chef, Hadco or GE refrigerator does not qualify for our three year Dometicare cooling unit coverage.

We will warrant cooling units purchased from **Dometic** for installation on other than Dometic refrigerators for two (2) years providing the installation is within our established installation specifications.

We will offer our three year Dometicare coverage on the following cooling units purchased from Dometic for out of warranty Dometic refrigerators only, for \$35.00.

RC 150	RM 215	RM 361	RM 66	RM 663	RM 763	RAK 100
RM 182	RM 235	RM 46	RM 66E	RM 76	RM 100	RAK 1302
RM 190	RM 36C	RM 46E	RM 66F	RM 77	RM 13C0	RA 1300
RM 211	RM 36E	RM 460	RM 660	RM 760	RM 1303	RA 1302
RM 211B	RM 360	RM 461	RM 661	RM 761	RA 100	RC 65

All Dometic cooling units for Dometic refrigerators manufactured prior to these models will no longer qualify for our Dometicare coverage.

## CROSS REFERENCE OF REFRIGERATORS MANUFACTURED BY A.B. ELECTROLUX

<u>HADCO</u>	<u>DOMETIC</u>	<u>GE</u>	<u>DOMETIC</u>
HR-2	same as RM 24	TG3-S-OB	same as RM 36
HR-3	same as RM 36C	TG4-S-OB	same as RM 45
HR-4	same as RM 46D	TG5-S-OB	same as RM 60
HR-6	same as RM 66D		
HR-7	same as RM 760		

<u>MAGIC CHEF</u>	<u>DOMETIC</u>	<u>INSTAMATIC</u>	<u>DOMETIC</u>
MKM	same as M-28	IM-2	same as RM 211
MKM-110	same as M-40	IM-3	same as Rhl 36E
MKM-150	same as M-52	IM-4	same as Rhl 46E
R-82, 83, 84,85,86	same as RM 75	IM-6	same as 66E
R-87	same as RM 77	IM-7	same as RM 77
R-88	same as RM 760	IM-10	same as RM 100



**Dometic**

**REFRIGERATOR BULLETIN  
NOVEMBER 1980 #37**

### **HEATING ELEMENTS 360-460-660-760**

Previous literature covering the following models, lists the wattage of 110 volt heating elements as follows:

RM360 - **120** watts  
RM460 - 135 watts  
RM660 - 175 watts  
RM760 - 250 watts

The ratings that are actually stamped on the replacement heating elements are as follows:

RM360 - **135** watts  
RM460 - 150 watts  
RM660 - 190 watts  
RM760 - 275 watts

These elements are identical and are covered under the same part numbers. The difference being that the newer elements have been rated at 115 volt input rather than 110 volt input.

The American Gas Association now requires that every refrigerator be supplied with a spare parts list included inside the cabinet. They are also requiring that all literature packaged inside the cabinet, from this point on, rate electrical input at 120 volt A.C. Therefore, the new spare parts list supplied with the refrigerator will list the wattage, at 120 volt input, as follows:

**R M360- 150** watts  
RM460 - 160 watts  
RM660 - 210 watts  
RM760 - 295 watts

Once again, these elements are identical to the previous elements and are covered under the same part numbers which are as follows:

RM360 - 173734-01 /3  
RM460 - 173736-0118  
**R M660- 173738- 0114**  
**R M760- 173740- 0110**

Should a customer be concerned that the wattage stamped on the heating element does not correspond to that shown in his spare parts list, the above information should be passed on to him.

# THE ABSORPTION SYSTEM

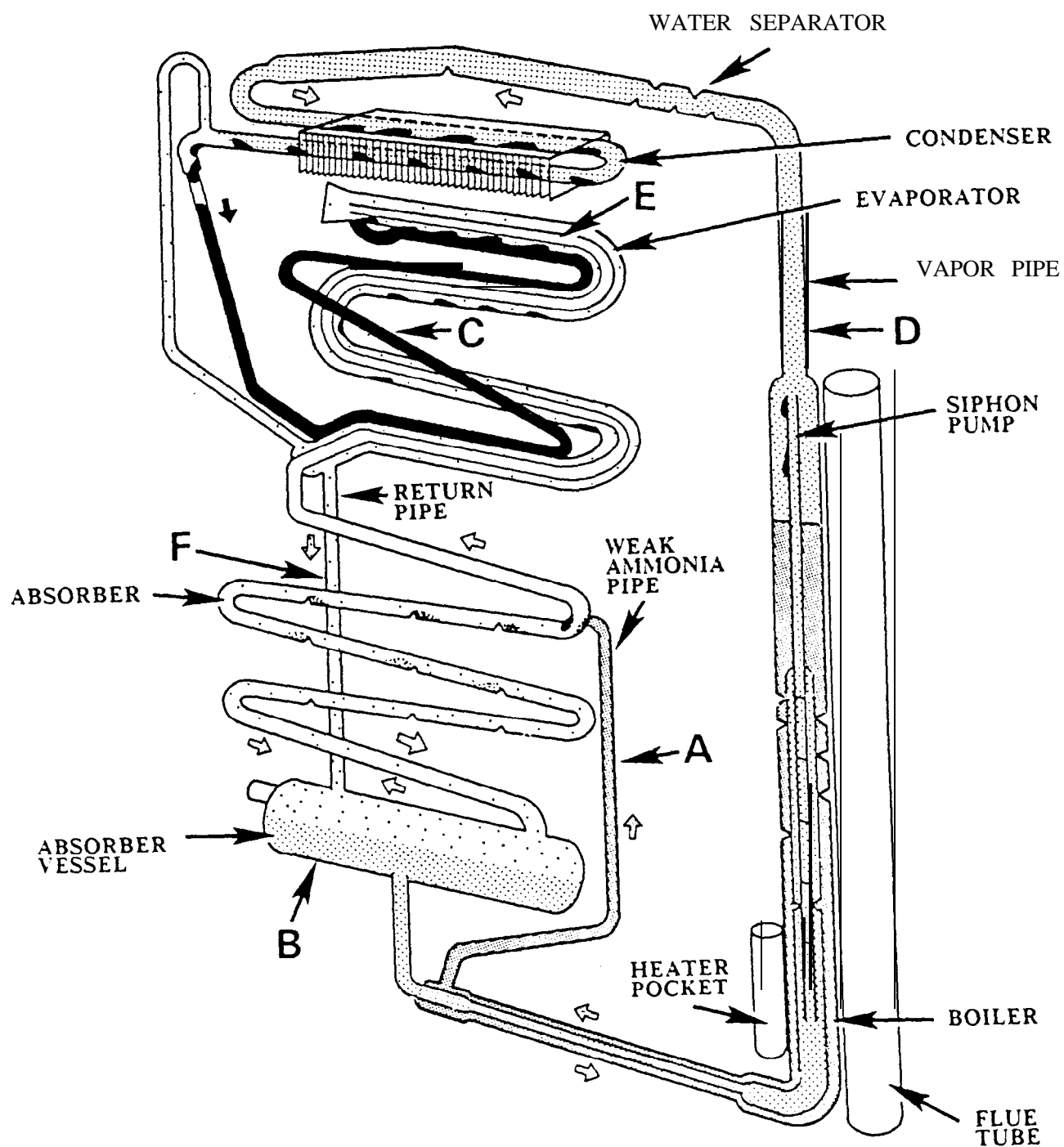

- A - WEAKAMMONIA SOLUTION
- B - STRONGAMMONIA SOLUTION
- c - LIQUID AMMONIA
- D - AMMONIA VAPOR
- E - HYDROGEN GAS
- F - HYDROGEN & AMMONIA VAPOR