



CASCADE 2 & CASCADE 2 GE

CARAVAN WATER HEATER USER'S INSTRUCTIONS

CAUTIONS

THE water heater flue cowl is located on the outside of the caravan and must not be obstructed in any way. During winter caravanning do not use if the cowl is likely to become blocked with snow.

ALWAYS wait 3 minutes before attempting to relight the heater after switching off or the heater going to fail-safe shut down.

WATER heaters (as with all other gas appliances) should be switched off and the gas cylinders turned off when the caravan is in motion.

THIS water heater does not contain asbestos or asbestos related products.

ANNUAL SERVICE As with all gas appliances it is recommended that this heater be serviced annually by a Carver approved dealer only.

FROST and sterilising see separate note.

If you have any problems with this water heater seek the advice of your nearest Carver approved dealer.

GENERAL DESCRIPTION

The Cascade 2 and Cascade 2 GE are storage water heaters with a 9 litre (2 gallon) capacity. The heater is installed through the wall of the caravan with only the flue cowl visible.

All the gas operational parts are contained within a single module which can easily be removed by a competent gas fitter from the outside of the caravan.

Control of the gas operation of the Cascade 2 and Cascade 2 GE is made from the wall mounted remote controller inside the caravan. This controller contains both the working and 12v DC fuses. On the front are the indicator lights which show the state of the heater. The lights on this controller do not show that mains electricity is being used.

The Cascade 2 GE requires the use of mains electricity which can be used as an alternative to the gas operation or used with the gas to facilitate a faster warm-up. The immersion element can be used on 220 or 240 volt 50 Hz and is rated at 605 and 660 watts respectively. The mains operation should be via a double pole switched outlet with a contact gap of at least 3mm in each pole and fused at 5 amp.

The thermostat for the appliance is not adjustable and is set give a water temperature of approx 70°C.

Two safety features are included on the Cascade 2 these being:

- 1) A pressure relief valve which automatically opens if the internal pressure exceeds 3 bar (44 p.s.i.) then closes when the pressure drops.
- 2) A fusible plug which is located behind the cowl. If the temperature rises to high this plug melts and sprays water onto the burner thus causing the heater to shut down.

The Cascade 2 GE in addition to the above safety features also incorporates a resettable high limit thermostat.

GAS OPERATING INSTRUCTIONS

CASCADE 2 & CASCADE 2 GE

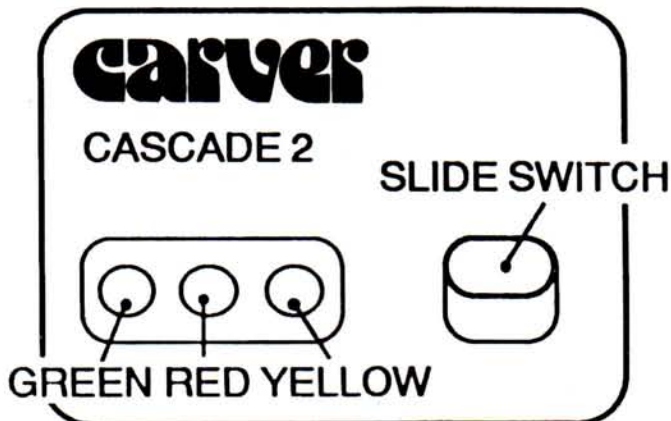

1. BEFORE SWITCHING ON

- a. Ensure that the gas is turned on and that the system is full of water i.e. water flows from the hot taps.
- b. Check that the 12 volt supply is connected and switched on. DO NOT use a battery charger as the only source of supply.

2. TO LIGHT THE HEATER

- a. Move the slide switch on the controller downwards.
- b. A continuous green light indicates that the heater is working satisfactory.

3. TO SWITCH THE HEATER OFF

- a. Move the slide switch upwards.

4. THE LIGHTS INDICATE

- a. GREEN. The heater is working satisfactory.
- b. GREEN and YELLOW. The DC voltage is below the 10.5 volts that is required to operate the heater. Recharge the battery.
- c. GREEN and RED. The heater has failed to ignite or that heater has gone to safety shut down. This is usually due to failure of the gas supply or air is in the gas system after fitting a new cylinder.
Switch the heater off and WAIT 3 MINUTES before attempting to relight the heater. If air in the gas system is the problem several attempts may be necessary before the heater ignites.

MAINS ELECTRICITY OPERATING INSTRUCTIONS CASCADE 2 GE

Ensure that the caravan is connected to the site mains and the supply is adequate. (the Immersion heater uses approx 2.75 amps.)

1. TO SWITCH ON

Switch on the isolation switch. If it is the illuminated type the light should indicate that the heater is working.

2. THERMOSTAT

The thermostat cannot be adjusted and is pre-set to approx 70°C.

3. OVER TEMPERATURE IMPORTANT

If the mains electrical supply to the heater is switched on but the heater is not working the over temperature thermostat may have operated.

This can be due to :

- a. Switching the heater on without water in the tank. Always check that the heater is full of water before switching on. i.e. water flows from the hot taps.
- b. Failure of the normal operating thermostat.
Manually reset the over temperature thermostat by pressing in the button in the centre of the electrical connection box. If the operating thermostat has failed the over temperature thermostat will again trip out. If this occurs **DO NOT USE THE IMMERSION HEATER AND CONSULT YOUR CARVER DEALER.**

FROST PRECAUTIONS

IMPORTANT

During periods when the heater is likely to freeze it **MUST** be drained down to prevent damage. It is also recommended that if the caravan is stored during the winter that the water system is drained.

TO DRAIN THE SYSTEM PROCEED AS FOLLOWS:

Park the caravan on level ground.

Ensure that the gas and electric are turned off.

Unscrew the drain plug which is located at the bottom left of the flue cowl on the outside of the caravan. When the end of the thread is reached pull the plug out slightly although the plug will still be retained it will allow the heater to drain.

Open both the hot and cold taps. To completely drain the water heater can take a considerable time. At least 9lt (2 Gallons) of water should drain from the heater. It is recommended to use a bucket to collect the water and ensure the water has drained completely.

Close the taps when the water has stopped flowing. It is recommended to leave drain plug out while the system is drained and replaced before refilling.

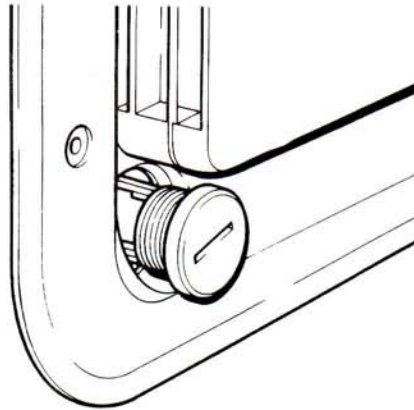

STERILISING

When cleaning the water system at the start and end of the season it is advisable to use a sterilising fluid e.g. Milton 2 , Chempro SDP or similar. **DO NOT USE DOMESTIC BLEACH, CAMDEN TABLETS OR SODIUM METABISULPHIDE.**

If a Crystal Water system is fitted, remove the filter and refit only the end cap of the filter as the carbon filter reduces the effectiveness of the sterilising agent. Always fit a new filter at the start of the season.

CARVER & CO (ENGINEERS) LIMITED
ENGINE LANE,
COPPICE SIDE INDUSTRIAL ESTATE,
BROWNHILLS, WALSALL, WEST MIDLANDS, WS8 7ES.
TEL: 0543 452122 TELEX: 338530 FAX: 0543 360760