

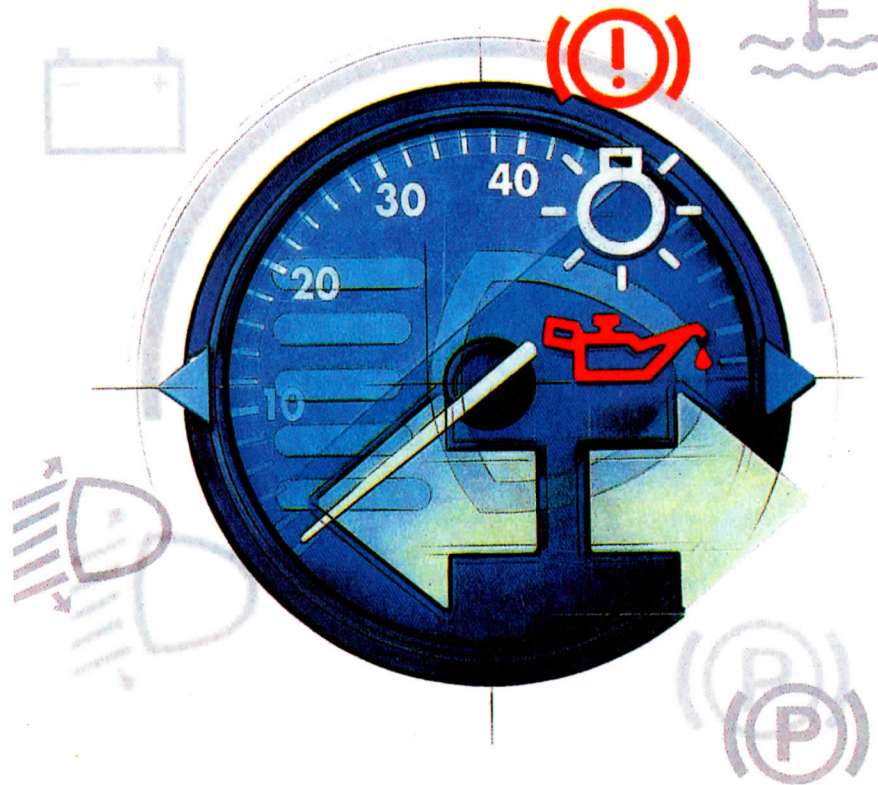

**Multivan  
Caravelle  
Transporter**

*Controls and  
Equipment - Part 1*



# CONTENTS

COCKPIT		Sun visors . . . . .	70
Overview . . . . .	3	Mirrors . . . . .	71
Instruments . . . . .	6	Heated rear window . . . . .	73
Tachograph . . . . .	16	Curtains . . . . .	73
Warning and indicator lamps . . . . .	17	SEATS AND STOWAGE	
Navigation system . . . . .	24	Front seats, seat heating . . . . .	74, 78
On-board computer with Multi-function indicator . . . . .	25	Head restraints . . . . .	77
Mobile telephone . . . . .	30	Pedals . . . . .	78
Hands-free system for mobile tele- phones / provision for mobile . . . . .	31	Luggage compartment cover . . . . .	79
OPEN AND CLOSE		Luggage compartment / surface . . . . .	80
Keys . . . . .	32	Stowage box . . . . .	82
Doors, wing doors . . . . .	34, 36	Seats in rear seat area	
Tailgate . . . . .	39	Multivan . . . . .	84
Central locking . . . . .	40	Caravelle / Kombi . . . . .	93
Radio wave remote control . . . . .	42	Rear seat bench (Double cab) . . . . .	103
Windows . . . . .	44, 45	Drink / can holder . . . . .	104
Sliding roof in cab (front) . . . . .	48	Thermal box . . . . .	106
Sliding/tilting roof in rear seat area . . . . .	50	Folding table in the Multivan . . . . .	110
Pop-up roof, roof bed . . . . .	52, 56	Electric sockets . . . . .	112
Bonnet . . . . .	58	Cigarette lighter, ashtray . . . . .	112, 113
Safety notes for working in the engine compartment . . . . .	60	Dropside (Pick-up) . . . . .	113
LIGHTS AND VISION		Roof rack . . . . .	114
Switches . . . . .	61	DRIVING	
Turn signal and main beam lever . . . . .	64	Manual gearbox . . . . .	115
Interior lights . . . . .	65	Automatic gearbox . . . . .	116
Windscreen wiper and washer system, wiper blades . . . . .	67, 69	Handbrake, ignition lock . . . . .	120, 121
		Starting/stopping engine . . . . .	123, 125
		Cruise control system . . . . .	126
		Electronic Stability Programme . . . . .	129
		Filling the tank . . . . .	130





Overview

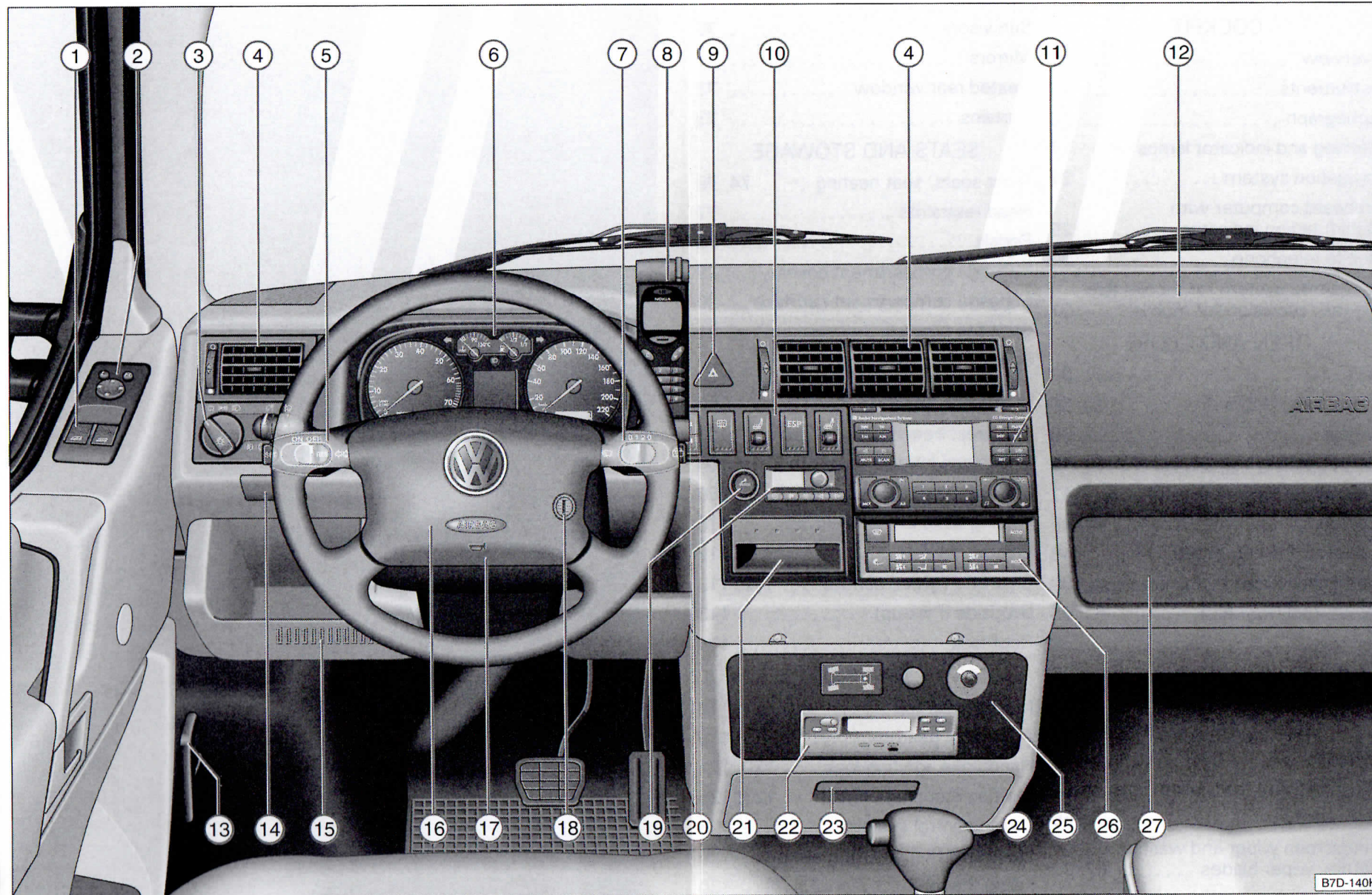

- Pos.
- 1 - Switch for electric windows
  - 2 - Remote control mirror
  - 3 - Light switch  
... Headlight range selector  
... Instrument lighting
  - 4 - Air vents
  - 5 - Turn signal and dip lever  
Cruise control
  - 6 - Combi-instrument  
Instruments  
Indicator lamps  
On-board computer  
Radio/navigation
  - 7 - Windscreen wiper  
Multi-function display
  - 8 - Mobile telephone
  - 9 - Switch for emergency system
  - 10 - Console for  
- Switch for roof rack  
- Switch for rear window heater  
- Knurled wheel for roof rack  
- Switch for ESP  
- Knurled wheel for roof rack  
- Switch for roof rack separate interior
  - 11 - Radio<sup>1)</sup> or Radio/navigation
  - 12 - Passenger Airbag
  - 13 - Bonnet release
  - 14 - Cold starting aid
  - 15 - Fuses
  - 16 - Driver's Airbag
  - 17 - Horn (only function ignition switched)
  - 18 - Ignition lock

B7D-140K



## CONTROLS AND EQUIPMENT

Pos.	Page
1 - Switch for electric windows	45
2 - Remote controlled exterior mirror	71
3 - Light switch	61
... Headlight range control	62
... Instrument and switch lighting	62
4 - Air vents	Booklet 3.1.2
5 - Turn signal and headlight dip lever	64
Cruise control system	126
6 - Combi-instrument:	
Instruments	6
Indicator lamps	17
On-board computer	25
Radio/navigation system <sup>1)</sup>	24
7 - Windscreen wiper/washer lever	67
Multi-function indicator	10
8 - Mobile telephone <sup>1)</sup> with mounting	30
9 - Switch for emergency light system	62
10 - Console for	
- Switch for roof fan	63
- Switch for rear window heating	73
- Knurled wheel for left seat heating	78
- Switch for ESP	129
- Knurled wheel for right set heating	78
- Switch for roof light and separate interior light	63
11 - Radio <sup>1)</sup> or Radio/navigation system <sup>1)</sup>	
12 - Passenger Airbag	Booklet 2.1
13 - Bonnet release handle	58
14 - Cold starting aid (Diesel engines)	124
15 - Fuses	Booklet 3.2
16 - Driver's Airbag	Booklet 2.1
17 - Horn (only functions with ignition switched on)	
18 - Ignition lock	121
19 - Cigarette lighter/ electric socket	112
20 - Auxiliary heater controls	Booklet 3.1.2
21 - Ashtray	113
22 - Tachograph	16
23 - CD Changer <sup>1)</sup>	83
24 - Gear lever (manual gearbox)	115
Selector lever (automatic gearbox)	116
25 - Console for	
... pull knob	
... differential lock	Booklet 3.2
... Filter saturation display	Booklet 3.2
26 - Controls	
... for heating/ventilation	Booklet 3.1.2
... for air conditioner	Booklet 3.1.2
... for Climatronic	Booklet 3.1.2
27 - Stowage compartment	82

● There are many possible equipment combinations. Therefore, the number and position of operating elements in the illustration may vary from those in your vehicle.

● Some of the items listed are only fitted on certain models or are optional extras.

● On right-hand drive vehicles the arrangement of the switches and the location of some items can vary. The symbols on the switches are the same as for left-hand drive vehicles.

<sup>1)</sup> Vehicles with a factory fitted radio, radio/navigation system, mobile phone or CD changer are supplied with a supplementary instruction manual.

When service installing a radio, please refer to the instructions in Booklet 3.2 under "Accessories, modifications and replacement of parts" and "Installing radio" or "Mobile telephones and 2-way radios".

Instruments

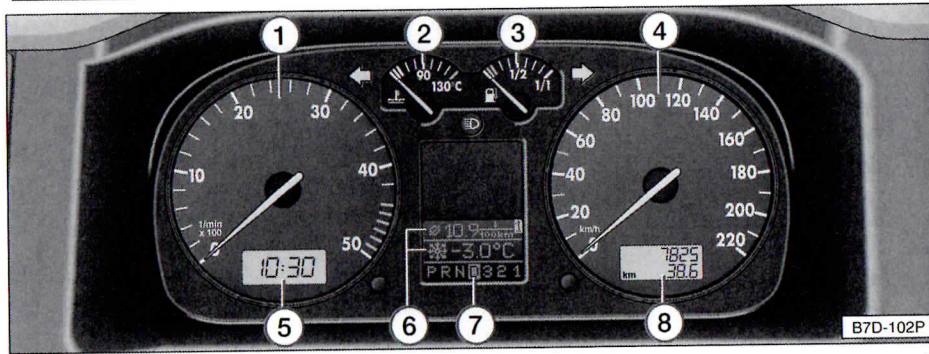

(only for TDI and 150 kW engines)

The arrangement of the instruments depends on the model.

Pos.	Page
1 - Rev counter	7
2 - Coolant temperature	8
3 - Fuel gauge	9
4 - Speedometer	9

5 - Digital clock	9
6 - Multi-function indicator* with variable service interval display*	10
7 - Selector lever indicator*	117
8 - Mileage recorder with variable service interval display	14

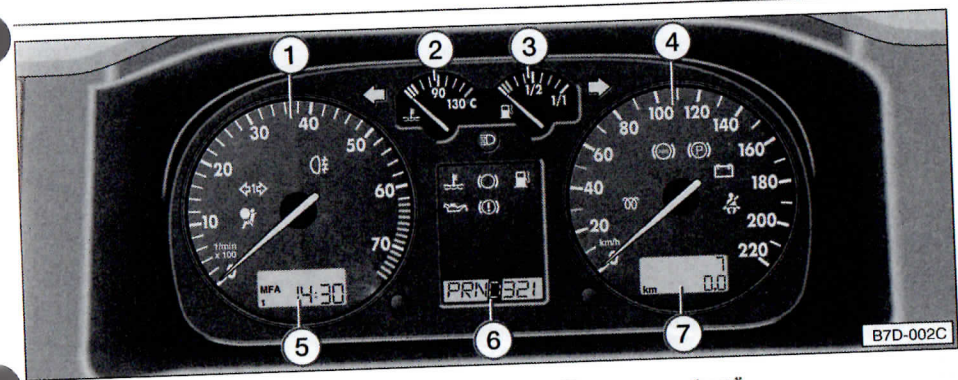

(not on TDI or 150 kW engines)

The arrangement of the instruments depends on the model and the engine fitted.

Pos.	Page
1 - Rev counter	7
2 - Coolant temperature	8
3 - Fuel gauge	9
4 - Speedometer	9
5 - Digital clock or multi-function indicator*	9
6 - Multi-function indicator*	10
7 - Selector lever indicator*	117
8 - Mileage recorder with service interval display	14

1 - Rev counter\*

The rev counter needle must not move into the red zone of the scale on any account. The starting point of the red zone on the scale depends on the engine.

**✿ Changing up in good time helps to save fuel and keeps the noise down.**

A lower gear should be selected if the engine revs are less than 1200 rpm. During the running-in period, high engine revs should be avoided.



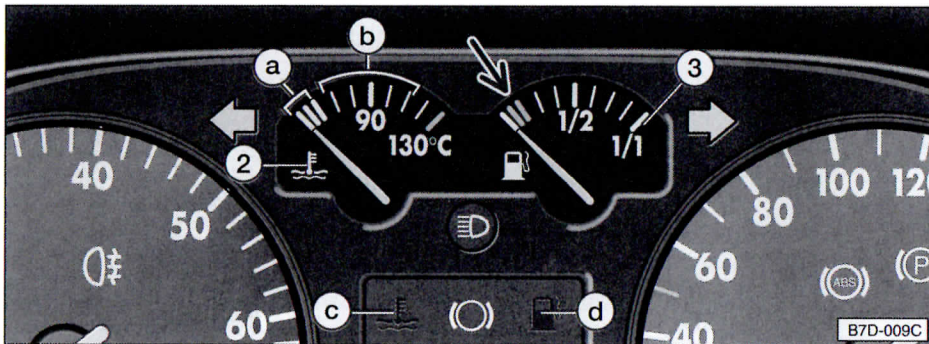

## 2 – Coolant temperature

The gauge starts to work when ignition is switched on, but it takes some time before the needle reaches its final position.

When the ignition is switched on the warning lamp (c) flashes for a few seconds as a functional check.

### a – Cold

Avoid high engine speeds and do not work engine too hard yet.

### b – Normal

When the vehicle is driven normally the needle should settle down in the central zone.

When engine is working hard and the ambient temperature is high, the needle may move a long way to the right.

**This is not serious as long as the warning lamp (c) does not flash.**

## c – Warning lamp

If the lamp flashes when driving, first check the coolant temperature display.

If the needle is in the normal zone, top the coolant up at the next opportunity.

The coolant temperature is too high if the needle is over to the right next to display area **b**. **Stop, switch engine off** and try to determine cause of trouble – see page 19.

### Warning

**Please refer to the warning notes on page 60 before carrying out any kind of work in the engine compartment.**

● **Additional lights in front of the cooling air intake interfere with the flow of cooling air. At high ambient temperatures and full throttle there is a danger that the engine will then overheat.**

## 3 – Fuel gauge



This gauge works when ignition is switched on.

The tank holds about 80 litres.

When the needle reaches the red reserve zone (arrow) and the warning lamp **d** lights up, there are about 10 litres of fuel left in the tank.

## 4 – Speedometer

During the running-in period, please refer to the instructions in Booklet 3.2. under "The first 1,500 kilometres – and afterwards"

## 5 – Digital clock

To set the time there is a button on the right below the rev counter.

● The hours are set by turning **anti-clockwise** until the stop. By turning the knob shortly, the clock will be altered by one hour. By turning and holding the knob, the alteration will continue.

● The minutes are set by turning **clockwise** until the stop. By turning the knob shortly, the clock will be altered by one minute. By turning and holding the knob, the alteration will continue.

With the knob the clock can be set exactly to the second:

● Turn knob to the right until the time is one minute before time to be set.

● Turn button to the right at the moment when the seconds indicator of an accurate clock shows a full minute.

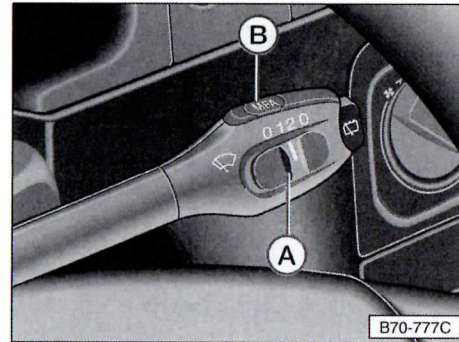
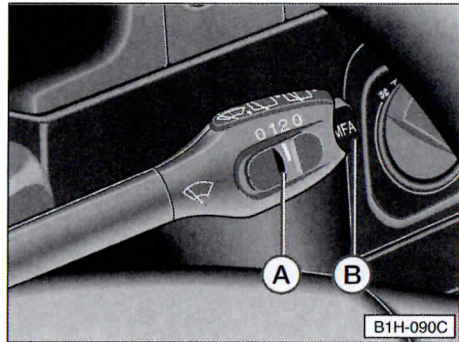

**5 - Multi-function indicator\***

**Controls on vehicles without a rear windscreen wiper**

The function of the multi-function indicator does not change for vehicles with or without a rear windscreen wiper.

**Controls on vehicles with a rear windscreen wiper**

By repeatedly pressing button **B** in the windscreen wiper lever with the ignition switched on, the additional information is displayed.

If button **B** is pressed for longer than 1 second, the function will change over automatically to the time display (not on TDI or 150 kW engines).

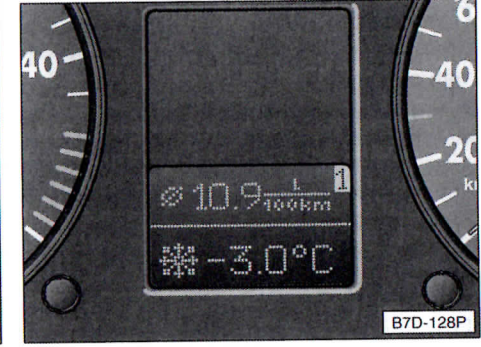
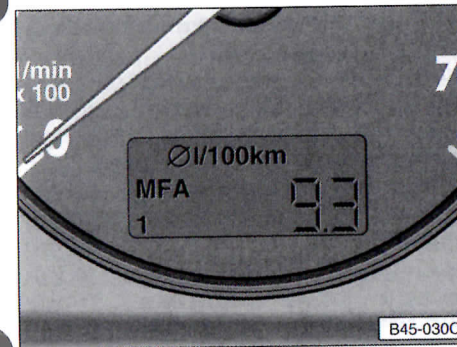

**Display**

**(not on TDI or 150 kW engines)**

In addition to the time display, the multi-function indicator (MFI) gives a whole range of additional information:

- Driving time
- Distance driven
- Current fuel consumption
- Average speed
- Average fuel consumption
- Ambient temperature
- Black ice warning

With the exception of the time, the symbol for the function switched on appears at the upper edge of the display.

A snowflake symbol (black ice warning) will also appear, depending on the ambient temperature.

**Display**

**(only for TDI and 150 kW engines)**

Alongside the permanent ambient temperature display, the multi-function indicator (MFI) gives a whole range of additional information:

- Driving time
- Distance driven
- Average speed
- Current fuel consumption
- Average fuel consumption
- Black ice warning

When the ignition is switched on the last function to be chosen will be shown in the display.

A snowflake symbol (black ice warning) will also appear, depending on the ambient temperature.



## The memories

The system is equipped with two automatic memories:

**A single journey memory (1)** collects the following data from the time the ignition is switched on to when it is switched off: Driving time, distance covered and fuel used.

From this data the average driving speed and the average fuel consumption are worked out.

If the journey is resumed within two hours of switching off the ignition, the new figures are automatically included in the calculation. If the journey is interrupted for more than two hours, the stored information is automatically erased.

**A total journey memory (2)** stores the data from any number of individual journeys up to a total of 99 hours and 59 minutes hours driving time, a distance of 9999 km and 999 litres of fuel consumed. This data is used to work out the consumption and speed averages for all the individual journeys.

If one of the given figures is exceeded, the memory is erased and calculation starts from the beginning again. Contrary to the single journey memory, this memory is not erased after a journey pause of more than two hours.

To **call up** the data the memories are selected by means of the switch **A** in the wiper lever:

- 1** – Single journey memory
- 2** – Total journey memory

The following data can be obtained from the memories:

- Distance driven
- Average speed
- Average fuel consumption
- Driving time

The amount of fuel used is not indicated.

## Erasing the memories

With the ignition switched on, both memories can be erased separately in each switch position by pressing switch **A** passed the appropriate detent position to 0 position for longer than one second.

If the battery is disconnected for any reason, the stored information is automatically erased.

## The displays

### Min (driving time)

Memory **1** shows the driving time which has elapsed since ignition was switched on or the memory cancelled is indicated – see also "Single journey memory".

Memory **2** shows the total driving time for all individual journeys indicated – see "Total journey memory".

The maximum time in both switch positions is 99 hours 59 minutes. When this figure is exceeded the indication starts at zero again.

### Miles (km) – Distance covered

The remarks made under "Driving time" also apply in principle to "Distance covered". The maximum distance indicated is 9999 km or 6214 miles.

### MPH (km/h) – Average speed

The remarks made under "Average fuel consumption" also apply here in principle.

## Ambient temperature

°C

The measuring range is from – 40 degrees C to + 50 °C.

When the vehicle is stationary or only moving very slowly, the indicated temperature could be slightly higher than the actual ambient temperature due to heat radiation from the engine or use of the auxiliary heater.

At ambient temperatures of between +4°C and –7°C, a snowflake symbol will also appear in the display (black ice warning).

This symbol will flash for approximately 5 seconds and will remain lit until the ambient temperature either rises above +4°C or falls below –7°C.

### Warning

**If the ambient temperature reading is used as an ice warning, remember that ice can form on the road at temperatures of 4°C.**

After switching off the ignition the last indicated temperature is stored in memory for about 45 minutes. If the ignition is switched on after 45 minutes or the vehicle is moved at about 30 km/h within the 45 minute period, a new up-to-date temperature will be displayed.

## MPG (ltr/100 km) – Current fuel consumption

The display shows the momentary consumption at ltr/100 km.

The calculation is carried out at 30 m intervals. When the vehicle is stationary, the last value displayed is stored.

If the momentary consumption function is chosen after switching on the engine, the average consumption is shown for the first 30-40 metres.

With the help of these figures, it is possible to adapt your driving style to the required consumption.

## MPG (ltr/100 km) – Average fuel consumption

The average consumption is indicated not the actual consumption at the time of reading.

The average fuel consumption is indicated, after switching on the ignition or erasing the memory being used, after a distance of about 100 metres. Up to this point a dash appears instead of a figure. When vehicle is moving the indicated value is up-dated every 5 seconds.

Memory **1** shows the average fuel consumption for the single journey.

Memory **2** shows the average consumption obtained during all single journeys – see "Total journey memory".

### Note

The amount of fuel used is not indicated.



**6 – Selector lever position\* display**

The selector lever position for automatic gearboxes is shown in the display – see page 117.

**7 – Odometer/ Trip meter**

The upper counter registers the total distance driven and the lower one the short trips.

The last figure of the lower counter indicates 100 m or 1/10 mile.

The lower counter (trip meter) can be zeroed by pressing the reset knob below the speedometer.

**7 – Service Interval Display**

**(not on TDI or 150 kW engines)**

If a service is due, one of the following services will appear in the lower speedometer counter (trip meter) :

- Oil Change Service ..... OIL
- Inspections Service ..... 01

The service display will be go out approx. one minute after the engine has been switched on. You can also switch back to the trip meter by pressing and holding (longer than 0.5 seconds) the reset button.

The Volkswagen dealer performing the service will reset the display.

If the service is not performed by a Volkswagen dealer, the display must be reset as follows:

- With the ignition switched off, press and hold the trip meter reset button below the speedometer.

- Turn the knob to reset the minutes on the digital clock to the right. "service ----" appears in the display.

**Notes**

- Only the desired service may be reset. The date for a service would otherwise be incorrect. You can switch between the individual services by pressing the reset knob.

- Do not zero the display between the service intervals – otherwise an incorrect reading will be shown.

- If the vehicle battery is disconnected the details in the service display are retained.

- If a defective speedometer is replaced, the service interval display must be reprogrammed. This should be carried out by a Volkswagen dealer. Should the display not be reprogrammed, then the service work must be carried out in accordance with the Service Schedule and not according to the service interval display.

**7 – Variable Service Interval Display**

**(only for TDI and 150 kW engines)**

3000 km before the next service work to be carried out, the following will appear in the display:

- "service km 3000" or
- "service in 3000 km".

The kilometre display for the next due service will go down in steps of 100 km.

If the Service interval has been reached "service" or "service now" will flash in the display.

The service display will be go out approx. 20 seconds after the engine has been switched on. You can also switch back to the trip meter by pressing and holding (longer than 0.5 seconds) the reset button.

The display will then be reset by the Volkswagen dealer after the service work has been carried out.

A print out of the work carried out will then be placed in your vehicle wallet as proof.

If the service is not performed by a Volkswagen dealer, the display must be reset as follows:

- With the ignition switched off, press and hold the trip meter reset button below the speedometer.

- Turn the knob to reset the minutes on the digital clock to the right. The display will then return to normal.

**Please note that you cannot fully reset the the service display in this way. You can only reset it back to the 15,000 km service.**

**Notes**

- Only the desired service may be reset. The date for a service would otherwise be incorrect. You can switch between the individual services by pressing the reset knob.

- Do not zero the display between the service intervals – otherwise an incorrect reading will be shown.

- If the vehicle battery is disconnected the details in the service display are retained.

- If a defective speedometer is replaced, the service interval display must be reprogrammed. This should be carried out by a Volkswagen dealer. Should the display not be reprogrammed, then the service work must be carried out in accordance with the Service Schedule and not according to the service interval display.



**Tachograph\***

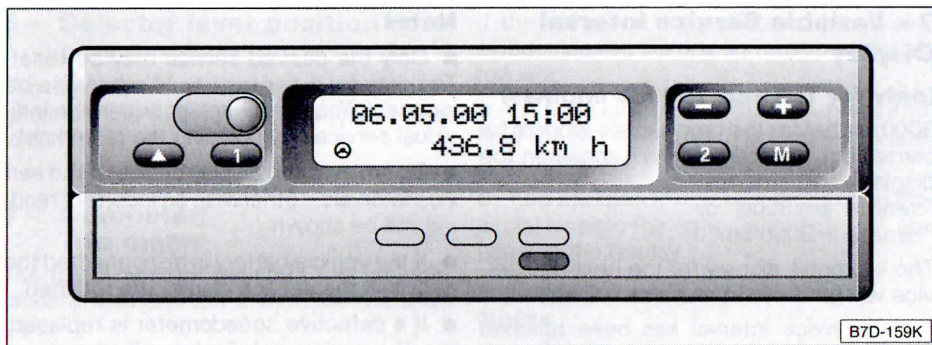

Factory-installed tachographs are supplied with a supplementary instruction manual.

When service installing a tachograph, please refer to the instructions in Booklet 3.2 under "Accessories, modifications and replacement of parts".

In many European countries the installation and use of a tachograph is obligatory for the following vehicles:

- 1 - Vehicles used for the commercial transport of goods with a permissible total weight including trailer or articulated trailer of more than 3.5 tons. It is immaterial whether the vehicle and the trailer or only one of the two is used for commercial goods transport.
- 2 - Vehicles which according to their design and equipment are suitable for and intended to carry more than 9 persons including the driver.

Details of the regulations can be obtained from local vehicle licensing authorities.

**Warning and indicator lamps**

①	(!)	⑥		⑪	<b>EPC</b>	⑬	
②		⑦		⑫		⑭	
③		⑧		⑬		⑮	
④	(P)	⑨		⑭		⑯	(ABS)
⑤		⑩		⑮			

The layout and number of the warning and indicator lamps in the combi-instrument depend on:

- the version of the engine and conditions specific to a particular country as well as
- the equipment you have selected and its possible combinations.

The symbols on the warning and indicator lamps can only be seen when the lamps are illuminated.

The figure illustrates all warning and indicator lamps.

**Warning lamps (light up in red)**

Pos.	Page
1 - Brake system/handbrake on	18
2 - Alternator	18
3 - Seat belt	18
4 - Handbrake on	19
5 - Coolant temperature/coolant level	19
6 - Engine oil pressure	20

**Indicator lamps (light up in yellow, green or blue)**

Pos.	Page
7 - Engine oil level	20
8 - Trailer turn signals	21
9 - Rear fog light	21
10 - Turn signals	21
11 - Engine management (petrol engine)	21
12 - Exhaust emissions warning lamp	21
13 - Diesel engine	
- Glow plug system	21
- Engine malfunction	21
14 - Main beam	21
15 - Airbag system	22
16 - Brake wear monitor	22
17 - Low fuel	22
18 - Electronic Stability Programme	22
19 - Anti-lock brake system	23



**1 – Brake system/  
handbrake on**

The warning lamp comes on when

- the handbrake is on
- the brake fluid level is too low

The ignition must be switched on.

In addition, a warning signal will sound on some models if the vehicle is driven at speeds higher than 6 km/h with the handbrake on.

The brake system warning lamp does not come on when the handbrake is on for vehicles with a separate warning lamp for handbrake on.

**Warning**

**If the warning lamp does not go out after the handbrake is released or comes on while the vehicle is being driven, the brake fluid level in the reservoir is too low. Stop the vehicle, do not drive on and call for expert assistance.**

**If the brake system warning lamp and the ABS indicator lamp are both on, the regulating function of the ABS may have failed. The rear wheels may block when the brakes are applied. This could possibly lead the rear of the vehicle to skid.**

**Drive carefully to the next Volkswagen dealer and have the fault corrected.**

**2 – Alternator**



The warning lamp comes on when the ignition is switched on. It must go out when the engine starts.

The alternator is driven by a long-life ribbed belt.

If the warning lamp lights during the journey, **stop, switch off engine** and check ribbed belt.

**Warning**

**Please refer to the warning notes on page 60 before carrying out any kind of work in the engine compartment.**

If the warning lamp comes on although the V-belt or ribbed belt is not broken or loose, one can normally drive on to the nearest Volkswagen dealer.

As the battery will continue to discharge, all electrical consumers which are not absolutely necessary should be switched off.

The ribbed belt should be checked by a Volkswagen dealer and changed if necessary.

**3 – Seat belt  
warning lamp\***



The warning lamp lights up (only for certain countries) for about 6 seconds after ignition as a reminder to fasten your safety belt.

If the seat belt is not fastened an acoustic signal will sound after switching on the ignition which will stop after 6 seconds or when the seat belt is fastened.

**Please refer to chapter "Seat belts" in Booklet 2.1.**

**4 – Handbrake on\***



When the **handbrake is pulled on** and the ignition is switched on, the warning lamp will light up. It must go out when the handbrake is released.

In addition, a warning signal will sound on some models if the vehicle is driven at speeds higher than 6 km/h with the handbrake on.

If the warning lamp does not go out although coolant level and fan fuse are in order, **do not drive on** – call in expert assistance.

If the trouble is only caused by the fan and assuming coolant level is in order and temperature warning lamp is out – one can drive on to the nearest Volkswagen dealer. In order to make good use of the air stream for cooling, do not let engine idle or drive very slowly.

**5 – Coolant temperature/  
Coolant level**



The warning lamp lights up for a few seconds as a functional check when ignition is switched on.

If the lamp does not go out afterwards or lights up or flashes when driving, either the coolant temperature is too high or the coolant level too low. An acoustic signal will sound 3 times as an additional warning:

**Stop, switch engine off** and check level. Add coolant if necessary. The type of coolant to be filled can be found in Booklet 3.2, "Cooling system".

**Warning**

**Please refer to the warning notes on page 60 before carrying out any kind of work in the engine compartment.**

If the coolant level is satisfactory the trouble may be due to a failure of the radiator fan. Check radiator fan fuse and renew if necessary.

**Warning notes**

● **Please note the following points to prevent scalding by hot coolant:**

– **Exercise caution when opening the coolant expansion tank! When the engine is hot the cooling system is under pressure – Danger of scalding! Therefore let engine cool down before unscrewing the cap!**

– **To protect the face, hands and arms you should cover the cap of the radiator with a large, thick cloth to offer protection against steam or hot fluid.**

● **Please ensure that the coolant does not drip on the hot exhaust or other hot engine components. The frost protection agent included in the coolant could ignite.**



**6 – Engine oil pressure** 

The warning lamp lights up for a few seconds as a functional check when ignition is switched on.

**Lights up or flashes red (engine oil pressure too low)**

If the warning lamp does not go out, an acoustic signal will sound 3 times as an additional warning. **Do not start the engine!** Check oil level and if necessary, add oil.

**Warning**

**Please refer to the warning notes on page 60 before carrying out any kind of work in the engine compartment.**

If the warning lamp comes on or flashes when driving – an acoustic signal sounds three times as an additional warning at engine speeds above 1500 rpm. **Stop, switch engine off!** Check oil level and if necessary, add oil – see Booklet 3.2.

If the lamp flashes although the oil level is in order, **do not drive on.** Do not even run the engine at idling speed – call in expert assistance.

If during the journey the engine is operated at a speed less than idling speed, it can happen that the oil pressure warning lamp lights up. Increase engine speed by accelerating or changing down.

**The oil pressure warning lamp is not an oil level indicator! The oil level should therefore be checked at regular intervals, preferably every time the fuel tank is filled.**

**7 – Engine oil level** 

**Lights up yellow (Engine oil level too low)**

If the indicator lamp lights up yellow, the engine oil level is probably too low. At the same time the warning "CHECK OIL LEVEL" appears briefly in the on-board computer\* display.

Check the oil level the next time you fill up the tank at the latest and top up with engine oil if necessary – see Booklet 3.2., "Engine oil".

**Warning**

**Please refer to the warning notes on page 60 before carrying out any kind of work in the engine compartment.**

The oil level warning will be deleted when the bonnet is opened. The warning will be shown again after approx. 100 km if no oil is refilled.

**Flashes yellow (Engine oil level measuring device is defective)**

The warning lamp will start to flash and an acoustic signal will sound if the engine oil level measuring device is defective.

At the same time the warning "OIL SENSOR WORKSHOP" appears briefly in the display of the on-board computer\*. The engine should be checked by a Volkswagen dealer as soon as possible.

The oil level **must** be checked regularly, preferably when filling up petrol, in the period between the defect warning and the engine check.

**8 – Trailer turn signals** 

The warning lamp\* flashes when turn signals are switched on when towing a trailer. If a turn signal fails on the trailer or vehicle, the warning lamp does not flash.

**9 – Rear fog light\*** 

The warning lamp lights up when the rear fog light is switched on. For further details see page 61.

**10 – Turn signals** 

The right or left arrow will flash depending upon which direction has been selected. If a turn signal fails, the warning lamp flashes twice as fast. (Not when towing a trailer).

Further details are given on pages 21 and 64.

**11 – Engine management system**

(petrol engine only)

The warning lamp comes on when the ignition is switched on and must go out when the engine is started.

If a fault occurs in the engine management system during the operation of an 85 or 150 kW petrol engine, it will be indicated by the indicator lamp flashing. The engine must be checked as soon as possible by a Volkswagen dealer.

**EPC**

**12 – Exhaust emission warning lamp\***

CHECK



(petrol engine only)

**Blinks:** If the catalyst can be damaged by misfires.

**Lights up:** If a fault which reduces the quality of the exhaust gas (e.g. a Lambda probe fault) occurs during a drive.

Let off on the accelerator, drive carefully to the next Volkswagen dealer and have the engine checked.

**13 – Glow plugs**



(Diesel engines only)

When the engine is **cold** the warning lamp comes on when key is turned to Drive position (ignition on).

If the warning lamp does not come on when the engine is cold, there is a defect in the glow plug system – call in expert assistance.

When the lamp goes out, start the engine immediately – see page 124.

When the engine is **warm** the glow plug lamp does **not** come on – the engine can be started straight away.

**Engine faults\***



If while driving a fault occurs in the diesel engine management system on a 65, 75 or 111 kW diesel engine, this is indicated by the warning lamp flashing. The engine must be checked as soon as possible by a Volkswagen dealer.

**14 – Main beam**



The warning lamp comes on when main beam is on or when the headlight flasher is used.



**15 –Airbag system\***

The warning lamp lights up for a few seconds when the ignition is switched on. **On vehicles with the passenger-side airbag deactivated** the warning lamp will then flash for approximately 12 seconds (see Booklet 2.1 under "Deactivating airbags").

If the warning lamp does not go out after the given period, or if it lights up, flashes or flickers during a journey, there is a fault in the airbag system. The system should immediately be checked by a Volkswagen dealer.

**16 –Brake wear monitor\***

The warning lamp will light up when the brakes being monitored have reached the wear level.

You should contact a Volkswagen dealer immediately so that the brake pads/linings can be checked.

The brake wear monitor checks the front left and the rear right brake. If the display lights up we recommend that the other brakes be checked as well.

On vehicles with a 16" running gear, the brake pad wear monitor checks the brake pads on all four wheels.

**17 –Fuel reserve\***

The warning lamp comes on when there are approximately 10 litres left in tank. A warning signal will also sound.

**18 –Electronic Stability Programme (ESP)\***

The warning lamp lights up upon ignition and should go out after approx. 2 seconds.

The ESP unit also has Traction Control System (TCS).

The lamp flashes when the system is in operation whilst the vehicle is in motion.

When the unit is switched off or if there is a fault in the system, the warning lamp is permanently on.

As the ESP unit functions together with the ABS and EDL, the ABS warning lamp will also come on if the ESP fails.

For further notes please refer to page 129.

**19 –Anti-locking brake system (ABS)\***

This warning lamp monitors the **ABS** and **EDL\*** systems.

**Anti-lock Brake System (ABS)\***

The warning lamp comes on for a few seconds when the ignition is switched on or the engine started. The lamp goes out after an automatic test sequence has been completed.

If the ABS warning lamp does not come on when the ignition is switched on, does not go out, or comes on when driving, the system is faulty.

A fault in the ABS is indicated as follows:

- **ABS warning lamp lights up** The vehicle can still be braked with normal braking system is without ABS. A Volkswagen dealer should however be consulted as soon as possible.

- **If ABS warning lamp lights up together with brake system warning lamp**, not only is the ABS system defective, but a change braking characteristics can also be expected.

**Warning**

**If both the ABS indicator lamp and the brake system warning lamp light up, you must stop the vehicle immediately and check the brake fluid level. If the fluid level is below the "MIN" mark, do not drive on. Please ask for expert assistance.**

**If the brake fluid level is at a satisfactory level, the fault might stem from the ABS. The rear wheels can block relatively quickly if the regulating function of the ABS fails. This could possibly lead the rear of the vehicle to skid.**

**Drive carefully to the next Volkswagen dealer and have the fault corrected.**

Further details on ABS are given in Booklet 3.2. under "Braking".

**Electronic Differential Lock (EDL)\***

The EDL system works in conjunction with the ABS. Failure of the EDL system is indicated by the ABS warning lamp lighting up. This lamp will also light up if the TCS and ESP should fail. The vehicle should be taken to a Volkswagen dealer as soon as possible.

Further details on EDL can be found in Booklet 3.2.



Navigation system\*

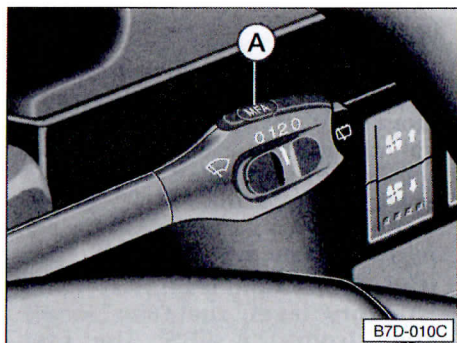

On vehicles with a **navigation system**, you can choose between two levels by pressing the button **A** in the wiper/washer lever (for longer than 2 seconds):

- Navigation display
- Multi-function display.

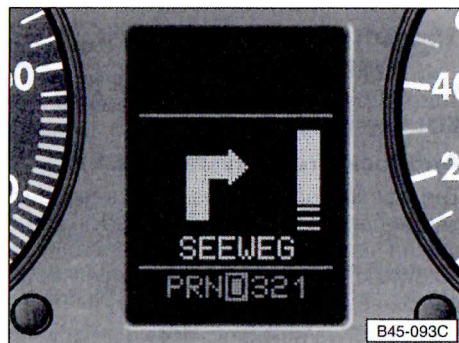

Driving information is displayed in the combi-instrument of Multivan and Caravelle models only – see figure.

Driving information of all other vehicles appears in the navigation system display field.

The operation of the Volkswagen navigation system is detailed in a **separate supplement**.

When the navigation system or multi-function indicator are in use, any faults that may occur will be shown with priority in the display via the on-board computer – as of page 25.

On-board computer with Multi-function indicator\*

Only on vehicles with a navigation system\*

The on-board computer constantly checks certain functions and vehicle components for their condition when the ignition is on and also when the vehicle is in motion.

These displays show the display of the multi-function indicator and the on-board computer. The functions and displays of the multi-function indicator are detailed on page 10.

Any faults in the function or any urgent repairs or service requirements will be indicated via an acoustic signal and, according to priority, displayed through red and yellow symbols in the combi instrument.

Furthermore, **information texts** will be shown in the display as an additional aid for the driver to the red and yellow symbols.

The **information texts** shown in the illustrations of this Owner's Manual are in German. The **information texts** and **driver's notes** will appear in the following languages according to the country:

English, French, Italian, Spanish, Portuguese and Czech.

Function check

Vehicles with manual gearbox

If there are any faults, these will be displayed after turning on the ignition. At the same time, the appropriate acoustic warning signal will sound:

Vehicles with automatic gearbox

After switching on the ignition, the following **driver's note** appears in the display when the selector lever is in position "P" and "N":

"APPLY FOOT BRAKE WHEN SELECTING GEAR WITH VEHICLE STATIONARY".

This note will disappear when a driving range is selected ("R", "D" etc.).

If there are one or more faults, the driver's note will disappear approx. 15 seconds after starting the engine and a fault symbol with the appropriate information text will appear in the display field.

For all vehicles:

If there is a fault an acoustic warning signal will also sound:

- **Priority 1 - three warning tones**
- **Priority 2 - one warning tone.**

Three warning tones will sound if faults of Priority 1 and 2 are present.

If there is a fault, the symbol will appear with the appropriate information text.

Note

Faults of **Priority 2** will not be displayed until **Priority 1** have been repaired or corrected!



**Priority 1 (Red symbols)**

**These Priority 1 symbols imply danger. For this reason you must stop the vehicle and switch off the engine!**

Repair the fault. Expert help might be needed.

If there is more than one fault of Priority 1 the symbols will appear one after the other for two seconds at a time. The symbols will flash until the fault has been corrected.

The following faults or warnings of priority 1 can be displayed:

**Engine oil pressure**

The information note says:

"STOP! OIL PRESS.  
STOP MOTOR! SERVICE MANUAL".

If this symbol flashes when driving, **stop, switch engine off**. Check oil level and if necessary, add oil – see Booklet 3.1, "Engine oil".

**Warning**

**Please refer to the warning notes on page 60 before carrying out any kind of work in the engine compartment.**

If the symbol flashes although the oil level is in order, **do not drive on**. Do not even run the engine at idling speed – call in expert assistance.

**The oil pressure warning lamp is not an oil level indicator! The oil level should therefore be checked at regular intervals, preferably every time the fuel tank is filled.**

**Brake system**

This symbol can monitor up to three functions at one time:

**1 – Brake fluid**

The information note says:

"STOP! BRAKE FLUID  
SERVICE MANUAL".

This symbol comes on when the brake fluid level is too low.

**Stop vehicle and check brake fluid level.**

**Warning**

**Please refer to the warning notes on page 60 before carrying out any kind of work in the engine compartment.**

**Warning**

**If the brake fluid level in the reservoir has fallen below the "MIN" level, do not drive on. Please call for expert assistance.**

**If the brake fluid level is satisfactory, the fault might stem from the ABS. The rear wheels can block relatively quickly if the regulating function of the ABS fails. This could possibly lead the rear of the vehicle to skid.**

**Drive carefully to the next Volkswagen dealer and have the fault corrected.**

**2 – ABS and EDL\* system**

The information note says:

"STOP! BRAKE FAULT  
SERVICE MANUAL".

**If the brake system warning lamp flashes whilst the ABS warning lamp is lit up**, not only is the ABS system defective, but you must also expect the brake system to respond differently to the normal response.

**Warning**

**Please refer to the warning notes on page 60 before carrying out any kind of work in the engine compartment.**

**Warning**

**If both the ABS indicator lamp and the brake system warning lamp light up, you must stop the vehicle immediately and check the brake fluid level. If the fluid level is below the "MIN" mark, do not drive on. Please ask for expert assistance.**

**If the brake fluid level is at a satisfactory level, the fault might stem from the ABS. The rear wheels can block relatively quickly if the regulating function of the ABS fails. This could possibly lead the rear of the vehicle to skid.**

**Drive carefully to the next Volkswagen dealer and have the fault corrected.**

Further details on ABS are given in Booklet 3.2. under "Braking".

The EDL system works in conjunction with the ABS. Failure of the EDL system is indicated by the ABS warning lamp lighting up. This lamp will also light up if the TCS and ESP should fail. The vehicle should be taken to a Volkswagen dealer as soon as possible.

**3 – Handbrake\***

The information note says:

"HANDBRAKE ON".

When the **handbrake is pulled on** and the ignition is switched on, the warning lamp will light up. It must go out when the handbrake is released. If it does not, there is a fault in the brake system.

A warning signal will sound if the vehicle is driven at speeds higher than 6 km/h.



**Coolant temperature/  
coolant level**

The information note says:  
"STOP! CHECK COOLANT  
SERVICE MANUAL".

If this symbol lights up or flashes when driving, either the coolant temperature is too high or the coolant level too low:

**Stop, switch engine off** and check level. Add coolant if necessary.

**Warning**

**Please refer to the warning notes on page 60 before carrying out any kind of work in the engine compartment.**

If the coolant level is satisfactory the trouble may be due to a failure of the radiator fan. Check radiator fan fuse and renew if necessary.

If the warning lamp does not go out although coolant level and fan fuse are in order, **do not drive on** – call in expert assistance.

If the trouble is only caused by the fan and assuming the coolant level is OK and the text in the display has disappeared – one can drive on to the nearest Volkswagen dealer. In order to make good use of the air stream for cooling, do not let engine idle or drive very slowly.

Please refer to Booklet 3.2. under "Coolant system" for further information.

**Warning notes**

● **Never open the bonnet if you can see steam or coolant coming from the engine compartment – Risk of scalding! Wait until no more steam or coolant can be seen.**

● **Do not touch the fan. The fan can switch on suddenly – even when ignition is switched off.**

● **Please note the following points to prevent scalding by hot coolant:**

– **Exercise caution when opening the coolant expansion tank! When the engine is hot the cooling system is under pressure – Danger of scalding! Therefore let engine cool down before unscrewing the cap!**

– **To protect the face, hands and arms you should cover the cap of the radiator with a large, thick cloth to protect against steam or hot fluid.**

● **Please ensure that the coolant does not drip on the hot exhaust or other hot engine components. The frost protection agent included in the coolant could ignite.**

**Priority 2 (Yellow symbols)**

If a yellow symbol appears **one** warning signal will sound. The symbols are a **warning**. The function displayed should be checked as soon as possible. If there is more than one warning, the symbols will appear one after the other for approx. 2 seconds at a time.

**Brake lining worn\***

The information note says:  
"CHECK BRAKE LINING"

You should contact a Volkswagen dealer so that the brake pads/linings can be checked. The brake wear monitor checks the front left and the rear right brake. If the display lights up we recommend that the other brakes be checked as well.

On vehicles with a 16" running gear, the brake pad wear monitor checks the brake pads on all four wheels.

**Fuel low**

The information note says:  
"FILL TANK"

Fill vehicle tank as soon as possible – see page 130.

**Engine oil level measuring device\*  
defective**

The information note says:  
"OIL SENSOR WORKSHOP"

The oil sensor is probably defective if the symbol flashes. You should go to a Volkswagen dealer as soon as possible. You can continue driving, but should check the oil level regularly, preferably when filling up with petrol.

**Warning**

**Please refer to the warning notes on page 60 before carrying out any kind of work in the engine compartment.**

**Engine oil level\* too low**

The information note says:  
"CHECK OIL LEVEL"

If the symbol appears, check the oil level the next time you fill up the tank and top off engine oil if necessary – see Booklet 3.2, "Engine oil".

**Warning**

**Please refer to the warning notes on page 60 before carrying out any kind of work in the engine compartment.**



## Mobile telephone\*

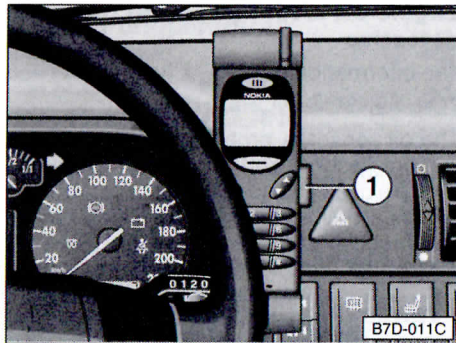

## Mounting for mobile telephone\*

The mobile telephone is fitted to an adapter for use in the vehicle whilst stationary. In this way, all the advantages of a regular car telephone (hands-off equipment, optimum transmission through exterior aerial etc.) can be employed to the full. The rechargeable battery of the telephone is also constantly recharged.

To telephone **without the hands-free system** you must lift the **mobile telephone including telephone adapter** out of the retainer:

To take out the telephone, hold it tightly and press the button **1** at the same time.

**Once you have taken out the mobile telephone with the telephone adapter, do not speak as normal into the mobile telephone, but rather into the rear side of the telephone adapter! Feedback could otherwise occur.**

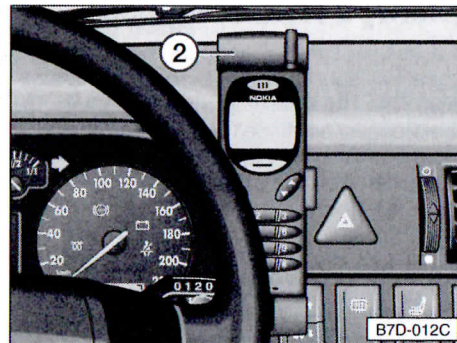

## Removing mobile telephone

The mobile telephone can be taken out of the telephone adapter for use outside of the vehicle.

Hold the telephone and press button **2** at the same time – the mobile telephone can now be taken out.

**Warning**

**Please concentrate on your driving above all!**

## Replacing mobile telephone

Place telephone in the adapter and push it to the front until it engages at the top.

**Notes**

The function of the Volkswagen mobile telephone is detailed in a separate supplement to this manual.

**Please read the notes in Booklet 3.2, "Mobile telephones and two-way radios".**

## Hands-free system for mobile telephones\*

With the hands-free system, it is possible to telephone without having to take the mobile telephone in your hand.

If you receive a telephone call, the voice of your conversation partner will be relayed over the speakers of the radio system. You have nothing further to do when responding; you simply react as if you were talking to a passenger in the vehicle.

The desired **conversation volume** can be set via the radio. Furthermore, it is necessary to set the listening volume of the mobile telephone once.

The operation of the units is described in a separate manual.

**Take the mobile telephone with you when leaving the vehicle or switch off the automatic call acceptance function as calls could otherwise be put through even when the radio is switched off.**

## Provision for telephone\*

The provision for a telephone is made up of:

- a **microphone** (between the windshield and the driver's door),
- the automatic **loudspeaker switch-over** of the radio system (for amplifying the conversation)
- and a combined **radio/telephone roof antenna**.

Furthermore, the **connecting cables for the interface box** are under the centre console.

**You will also need the following in order to be able to telephone:**

- an **interface box**
- a **mobile telephone retainer**

Both parts must be suitable in size for the mobile telephone!



Keys

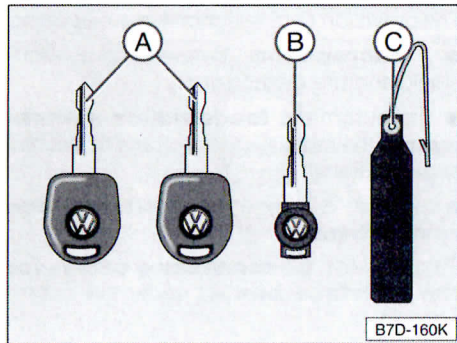

The vehicle is supplied with two<sup>1)</sup> main keys **A** and one emergency key **B** which fit all locks.

We recommend that you keep the emergency key separate from the vehicle registration papers. The emergency key should only be used temporarily.

**Warning**

● **Always withdraw key from ignition whenever you leave the vehicle – even if only for a short time. This is particularly important if children are to remain in the vehicle. They could otherwise start the engine or electrics – e.g. electric windows. Risk of accident!**

● **Do not withdraw key from lock until vehicle is stationary! The steering lock could be unintentionally engaged.**

<sup>1)</sup> Four keys are provided in some export markets.

**Notes**

**Every key contains electronic components! Protect the keys from moisture and hard jolts.**

Vehicles equipped with radio-wave remote control have two radio-wave keys and one emergency key. Further notes on the effective range and the function of the radio-wave key can be found from page 42 onwards.

A further key is provided for each of the items listed below. These keys will also only fit the appropriate lock:

- lockable stowage area\* in the dash panel on the front passenger side
- lockable stowage area\* in the left door trim.

**Replacement keys**

**For reasons of security, replacement keys are only available from Volkswagen dealers.**

**Key tag**

The key number, which is needed to obtain replacement keys, is located on the key tag **C**. Volkswagen dealers can only order replacement keys if they have this number.

**The key tag should be kept separately as keys can only be replaced using these numbers.**

If you sell the vehicle, you should also give the buyer this key tag.

**Electronic immobilizer**

The immobilizer prevents unauthorized persons using your vehicle.

A micro-chip is located in the head of the key which automatically deactivates the immobilizer when the key is inserted in the ignition lock.

The system is automatically activated when the ignition is switched off.

**The engine can thus only be started with a correctly coded Genuine Volkswagen key.**

**Trouble free operation of your vehicle can only be guaranteed when using genuine keys.**

**Security locking\***

**(only for special vehicles)**

A further key is provided for each of the items listed below. These keys will also only fit the appropriate lock:

You can lock and unlock the locks of the sliding door and the tailgate or wing doors only with the security key. The main and emergency keys do not fit these locks.

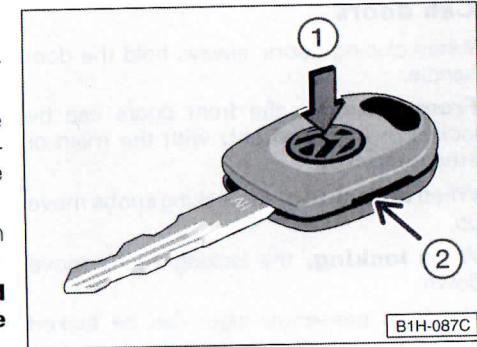

**Key with built-in light\***

There is a built-in light in one of the two keys. To switch the light on, press the centre of the key (arrow 1).

**To change battery or bulb**

- Insert a coin in the slot at the side of the key (arrow 2) and lever the upper part off.
- Change battery or bulb.

Spare batteries and bulbs can be obtained from Volkswagen dealers.

**✿ The flat battery should be disposed of with due respect for the environment**



## Doors

### Cab doors

When closing doors, always hold the door handle.

**From outside**, the front doors can be locked or unlocked only with the main or emergency key.

When **unlocking**, the locking knobs move up.

When **locking**, the locking knobs move down.

The front passenger door can be locked from outside without using the key: Just press locking knob down and close door.

The driver's door cannot be locked when open by pressing the locking knob down and closing door. This prevents you from leaving the key in the car and forgetting it.

**From inside** all the doors can be locked by pressing down the locking knobs.

As long as the knobs are pressed down the doors cannot be opened from inside or outside.

#### Warning

**Locked doors prevent persons from entering the car forcibly e.g. at traffic lights. They make it more difficult, however, for outside help to open the doors in an emergency.**

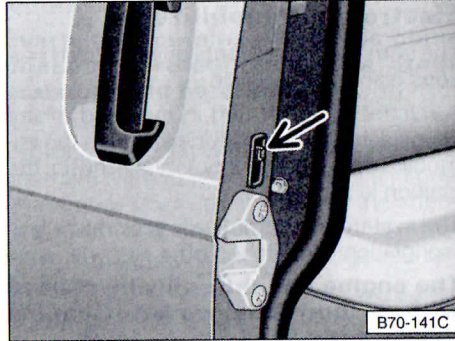

### Sliding door

#### Child-proof lock on sliding door

When the child-proof catch is engaged – lever on door lock down – the inner lock release lever is inoperative. The door can only be opened from outside with the locking knob in the up position.

**From outside**, the sliding door can be locked or unlocked with the main or emergency key.

See the instructions on page 33 for vehicles with security locking\*.

The sliding door can also be locked from outside without using the key: Press locking knob down and close door.

**From inside**, the sliding door is locked by pushing down the locking knob.

As long as the knob is pressed down the door cannot be opened from inside or outside.

When the vehicle is moving, the door must always be properly closed, but when carrying passengers the locking knob should be left in the upper position so that the door can be opened from outside in an emergency.

In the fully opened position the sliding door is held open by a retainer.

#### Warning

● **Never open the sliding door when the vehicle is in motion – Risk of injury!**

● **The sliding door can, if held open by the retainer, close unexpectedly if the vehicle is parked on an incline and the door is accidentally knocked when entering – Risk of injury!**

● **If the sliding door is opened inattentively or hastily with the wing doors\* fully open to an angle of 265°, there is a risk of substantial injury or damage to the vehicle.**



**Wing doors\***

**Warning**

- Do not close the wing doors with your hand on the window. The glass could shatter – Risk of injury!
- After closing the wing doors, always pull on them to make sure that they are properly closed – otherwise they could open suddenly when vehicle is moving, even though the key has been turned in the lock.
- Never drive with slightly or even fully open wing doors as exhaust gas will otherwise be drawn into the vehicle interior! **Danger of asphyxiation!**

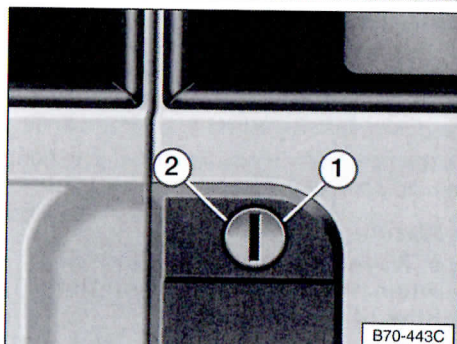

**Right-hand wing door**

On some model versions, it is necessary to swing the spare wheel bracket to the right before opening the tailgate – see Booklet 3.2, "Vehicle tools, spare wheel".

**From outside,** the wing door can be locked or unlocked with the main or emergency key. When the door is unlocked, the locking knob goes up; when locked, it goes down.

See the instructions on page 33 for vehicles with security locking\*.

**Unlocking**

Turn key to position 1 and operate door handle.

**Locking**

Turn key to position 2.

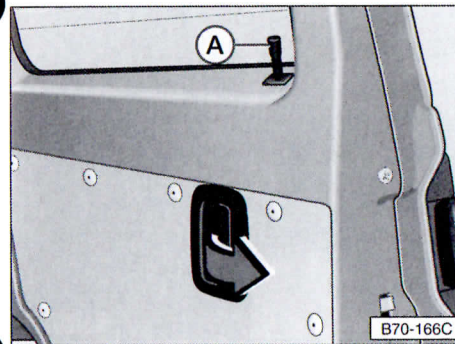

**From inside** the door is locked by pressing down the knob (A).

As long as the knob is pressed down the door cannot be opened from inside or out.

To open the door lift the lever in the direction of arrow.

In the fully open position (approx. 90°) the door is held by a check strap.

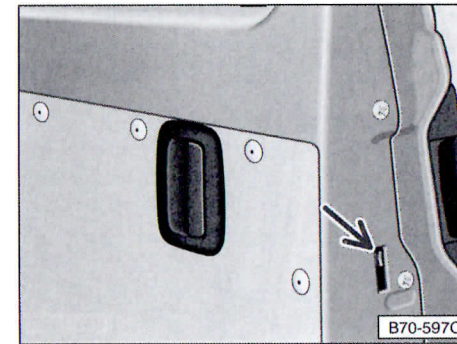

**Child-proof lock on wing door**

When the child-proof lock is engaged – lever on door lock down – the inner lock release lever is inoperative. The door can only be opened from outside with the locking knob in the up position.

**Please also refer to the further notes on next page.**



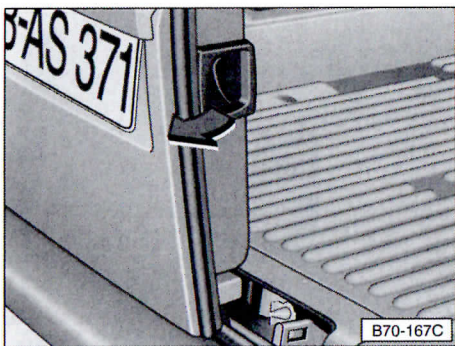

**Left-hand wing door**

The left-hand door can be opened when the right-hand door is open. To open, pull release lever as far as stop in direction of arrow.

In the fully open position (approx. 90°) the door is held by a check strap.

- **When closing the wing doors always ensure that the left-side door is closed first.**

**Warning**  
See warning concerning tailgate on page 36.

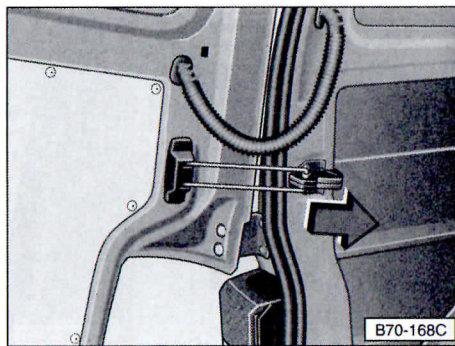

**Unhooking door check strap**

Both doors are held in the open position (approx. 90°) by check straps. To open the doors further the check straps can be unhooked

To unhook swing door inwards slightly, until check strap slides out of retainer and then pull check strap inwards.

The wing doors are not held open in the fully open position (approx. 180°). When doors are closed the check straps engage again automatically.

**Note**

In the fully open position, the wing doors\* with an opening angle of 265° are held onto the side panel with magnets.

**Tailgate**

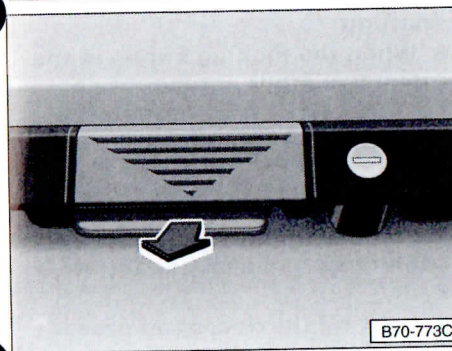

**Child-proof lock\***

Vehicles with an opening lever on the inside of the tailgate are fitted with a child proof lock. When the child proof catch is engaged – lever on lock moved down – the inner lever is blocked. The tailgate can then only be opened from outside.

**To close tailgate/boot lid** pull it down and slam it to gently.

To make the tailgate easier to pull down there is a loop on the inside.

**Warning**

- **Do not close tailgate with your hand on the window. The glass could shatter – danger of injury!**
- **After closing the tailgate, always pull up on it to make sure that it is properly closed – otherwise it could open suddenly when vehicle is moving, even though the key has been turned in the lock.**
- **The tailgate must always be fully closed when vehicle is moving; otherwise exhaust gas will be drawn into the vehicle interior!**  
**Danger of asphyxiation!**

On some model versions, it is necessary to swing the spare wheel bracket to the right before opening the tailgate – see Booklet 3.2, "Vehicle tools, spare wheel".

The tailgate lock can be locked or unlocked with the main or emergency key.

See the instructions on page 33 for vehicles with security locking\*.

**Warning**

**When a luggage carrier is fitted to the tailgate (e.g. for bicycles) you should note that the tailgate might not open fully or might drop back of its own accord due to the extra load.**

**In this case, before loading the luggage area, support the tailgate separately or remove the baggage from the carrier.**  
**Risk of injury!**

**To open** the tailgate when key slot is horizontal, pull the release behind the trim strip on tailgate and lift tailgate.

**To open from inside\***

On the inside of the tailgate there is, on some model versions, either an opening lever or an emergency lock release which can be reached through a hole in the trim. This makes it possible for vehicle occupants to leave the vehicle via the tailgate in an emergency.

The tailgate/boot lid is locked when the key slot is vertical (with central locking horizontal as well).



## Central locking\*

With the central locking all the doors, and – depending on the position of the tailgate lock – the tailgate can be locked and unlocked.

The system is operated from the **driver's door** or **front passenger door** – from outside with the main or emergency key, from inside with the locking knob.

When locking, the locking knobs on all doors must move down. If the knob on one door does not move at any time, open the door concerned and close it properly.

**Sliding door and tailgate or wing door** can be locked or unlocked separately with the main or emergency key.

See the instructions on page 33 for vehicles with security locking\*.

● If the central locking should develop a fault, all the locks can be operated normally, see page 34.

### Warning

● **When the locking knobs in the driver's or front passenger doors are pressed down all other doors are locked automatically.**

**Since it would be difficult to render assistance from the outside in an emergency, when the doors are locked, children should never be left in the vehicle on their own.**

● **Locking the doors can prevent them from bursting open in an extraordinary accident situation. Locked doors also prevent uninvited persons from entering the vehicle, e.g. at traffic lights. However, in an emergency they also make it more difficult for outside help to get into the vehicle.**

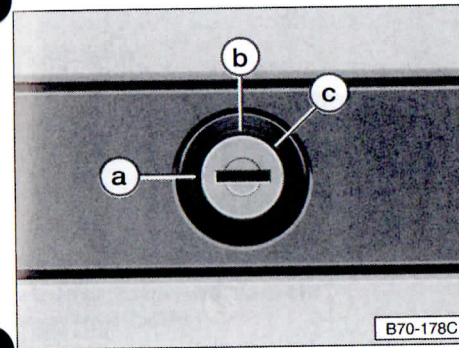

B70-178C

### Tailgate

● When the key slot is horizontal (**a**), the tailgate/boot lid is locked or unlocked automatically by the central locking system. It can also be locked or unlocked separately with the main or emergency key.

See the instructions on page 33 for vehicles with security locking\*.

● When key slot is vertical (**b**) the tailgate/boot lid will be locked all the time after closing. It can then only be unlocked with the key.

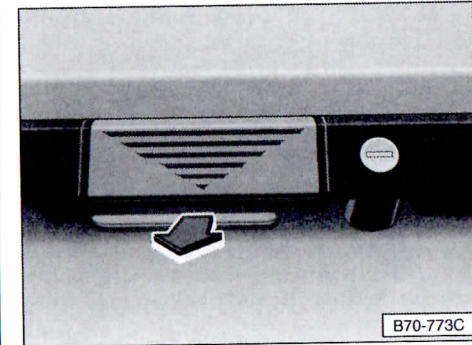

B70-773C

● To unlock the tailgate turn the key fully to the right (**c**) and hold it in this position.

Pull the release behind the trim strip in the direction of the arrow and open the tailgate.

### Warning

**See warning concerning tailgate on page 39.**



## Radio wave remote control\*

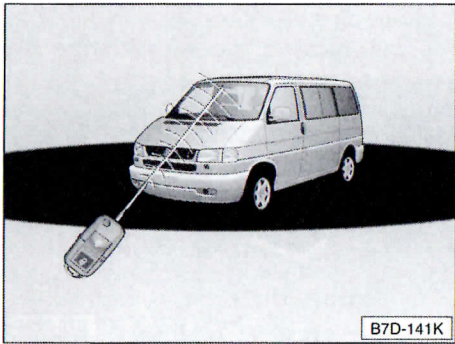

The central locking mechanism can be opened and closed with the radio wave remote control. The key is not needed.

The radio wave transmitter with its battery is located in the handle of the key. The two radio wave receiver is located inside the vehicle.

The **effective range** (blue zone) of the remote control is shown in the illustration. The maximum range depends on various conditions.

The range will reduce as the batteries lose power.

When the close or open button is pressed, an indicator lamp in the key will flash. If this lamp does not flash, the battery in the key might be empty.

Uncoded second keys can be obtained from Volkswagen dealers. The second key must, however, be synchronized by a Volkswagen dealer as the code for the immobilizer also has to be initialized in the head of the key.

In total, four keys can be used.

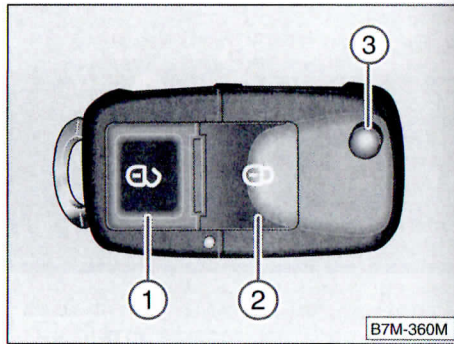

### Opening and closing the vehicle

To **unlock** the vehicle, point the key from within the effective range at the vehicle and briefly press the "open" button **1**. To **lock** the vehicle, briefly press the "close" button **2**.

If you want to open or close the vehicle mechanically, the key bit must first be folded out. To do this, press the release button **3**. You must also press on this button to fold the key bit in.

All turn signals will light up briefly to confirm that the doors have been locked using the radio wave remote control.

If the doors are unlocked using the opening button **1**, they are automatically locked again if the doors or tailgate are not opened within 30 seconds. This function prevents the vehicle from being opened **unintentionally for an extended period of time** within the effective range of the radio wave remote control.

#### Note

The automatic relock function is not supported on vehicles with a double cab.

### Radio wave key without function

The following solutions should be tried one after the other if the vehicle cannot be either locked or unlocked using the remote control key. This should reset the lock/unlock function.

Please contact Volkswagen Service if the points listed do not help.

#### Unlock/lock the vehicle mechanically

Insert the key bit of the radio wave remote control key in the lock of the driver's door and either lock or unlock the vehicle once mechanically.

#### Synchronise the radio wave key

- 1 - Insert the key bit of a radio wave key in the ignition lock.
- 2 - Within five seconds, turn the ignition on, off and then back on again.
- 3 - After turning the ignition back on you have 15 seconds to lock your vehicle mechanically using the second key or the knob in the driver's door.
- 4 - After locking the vehicle you have 30 seconds to operate either the open or close button **twice**.
- 5 - A new code is defined between the key and the control unit. The synchronisation procedure is complete.

### Replace the battery

We recommend having the battery changed by Volkswagen Service.

Fold out the key bit. Insert the flat blade of the screwdriver from the vehicle tool kit in the slot of the radio wave key. Pry open the upper and lower key parts by moving screwdriver back and forth carefully in the slit.

Renew the battery. Only batteries of the same type may be used. Take care to ensure proper polarity when installing the battery.

**The flat battery should be disposed of with due respect for the environment**

### Radio wave authorisation

The radio wave remote control fulfils all authorisation conditions and has been approved by the Federal Approvals Office for Telecommunications of the Federal Republic of Germany.

All components have been marked according to current stipulations.

This authorisation is the basis for approval in other countries.



**Sliding window\***

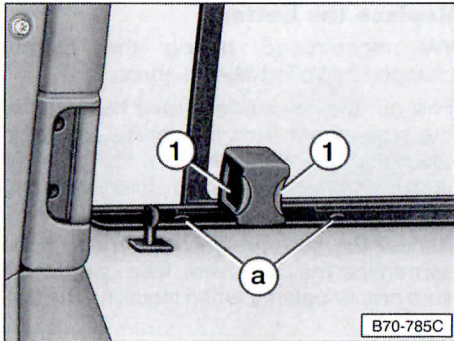

**Closing**

Press the two buttons (1) at the same time and slide window closed. Please ensure that the sliding window lock engages properly.

**Fly screen**

The sliding window can be fitted with a fly screen.

The fly screen can be removed by lifting the screen, pressing it upward and removing.

Installation is performed in the reverse order.

**Opening**

Press the two buttons (1) at the same time and slide window open.

The sliding window can be locked in several positions (a).

**Warning**  
**In order to avoid injury to passengers and damage to the sliding window, it must always be locked in one of the positions (a) whilst the vehicle is in motion.**

**If the window is not locked in position it could slide forward during a sudden braking manoeuvre or in an accident.**

**Electric windows\***

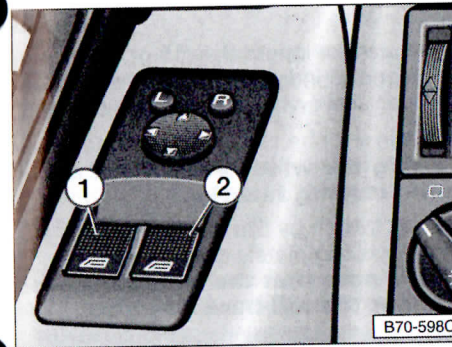

The switches for both windows are located in the driver's door (see illustration). There is a separate switch for the passenger window in the passenger's door.

- 1 – Driver's door
- 2 – Front passenger door

Electric windows with an automatic closing function\* are equipped with a **roll-back function**.

The window stops closing automatically should anything block it.

**Warning**

● **Always remove the ignition key when leaving the vehicle – even if only temporarily. Please ensure that children are never left unattended in the vehicle.**

**The electric windows are, however, only fully non-functional when a door or the tailgate have been opened.**

● **Be careful when closing the windows! Careless or uncontrolled closing of the windows can cause injuries.**

● **No persons may remain in the vehicle when it is locked from the outside, as the windows cannot be opened in the case of an emergency.**

**Function of electric windows with ignition on**

**Opening**

Press and briefly hold the front edge of the respective button and the window will open fully (automatic window opening).

If the switch is pressed again, the window will stop immediately.

**Please also refer to the further notes on next page.**



**Closing windows with automatic closing function\***

Lift and briefly hold the front edge of the respective button and window will close fully (automatic window closing).

If the switch is pressed again, the window will stop immediately.

**The roll-back function**

- 1 - If the window in the driver's or passenger door is hindered whilst closing through stiffness or by an obstacle (roll-back function), the window will open again immediately.
- 2 - After the window has opened, you must lift and hold the appropriate switch for the window affected again within 10 seconds. If the window is still hindered whilst closing through stiffness or by an obstacle, the window will stop closing.
- 3 - After the window has stopped, you must lift and hold the switch again within 5 seconds in order to close the window.

**The window will now close without the roll-back function.**

**Warning**  
Careless or uncontrolled closing of the windows can cause serious injuries!

**Note**

If you wait for longer than 10 or 5 seconds between the individual steps, the window will open again when the switch is operated again.

**Closing the windows without automatic closing function**

Lift the switch by the front edge until the window is completely closed.

**Please note that the window closes without the roll-back function.**

**Warning**

Careless or uncontrolled closing of the windows can cause serious injuries!

**Function of the electric windows with ignition switched off**

After the ignition has been switched off, the windows can still be operated for about ten minutes so long as a door or the tailgate are not opened.

**Opening**

Press and briefly hold the front edge of the respective button and the window will open fully (automatic window opening).

If the switch is pressed again, the window will stop immediately.

**Closing**

Lift the switch by the front edge until the window is completely closed. There is no automatic closing function.

If the window in the driver's door is hindered whilst closing through stiffness or by an obstacle (roll-back function), the window will open again immediately.

In this case you can only close the window again after the ignition has been switched on.

**Note**

The automatic opening/closing function\* on the driver's and passenger door windows will not function after the vehicle battery has been disconnected/reconnected.

To reinstall this function after reconnecting the battery, please note the following points.

Switch on ignition and open the window in the driver's door fully using switch (1). Then release the switch.

Fully close the window by lifting the switch (1). The automatic closing and opening function in the driver's door has now been reinstalled.

Repeat this procedure for the window in the passenger door using switch (2).



## Sliding roof\* in cab (front)

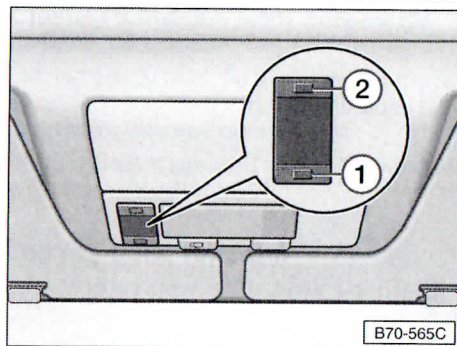

### Sun screen

The sun screen to prevent intensive sun rays shining in can be slid open or closed by hand with roof open or closed.

#### To open

Press the sun screen upwards at front on grip and slide screen fully to rear.

#### To close

Slide screen forwards against spring pressure, until the retaining lug engages.

With ignition switched on, the roof can be opened and closed with the switch.

#### To open

Press front of switch **2**.

#### To close

Press rear of switch **1**.

#### Warning

● Please be careful when closing the roof! Injuries could occur if the roof is closed without due attention or too quickly. The ignition key should, for this reason, always be removed when leaving the vehicle.

● The sliding roof could be blocked by the roof load when opening. Please ensure, therefore, that there is enough room between the sliding roof and the roof load.

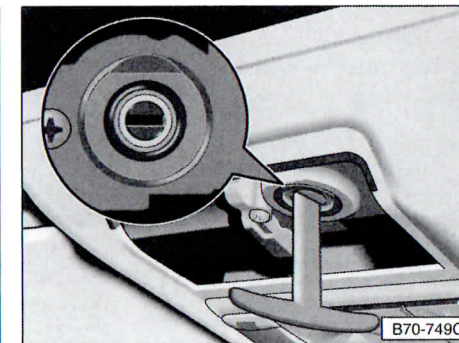
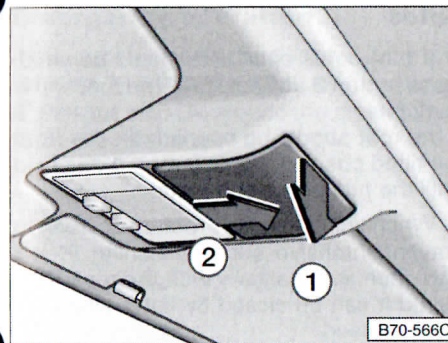

### Emergency operation

If the system should develop a fault the roof can also be closed by hand.

- Pull cover down at rear until it disengages (arrow **1**) and take out to rear (arrow **2**).
- Remove crank from retainer in cover .

- Insert crank in opening and close the sliding roof by turning the crank.

- Place the crank in the designated retainer.

- Fit cover as follows:

Slide cap onto the frame with retaining lugs at front and then press up at rear until it locates.



## Sliding/tilting roof\* in rear seat area

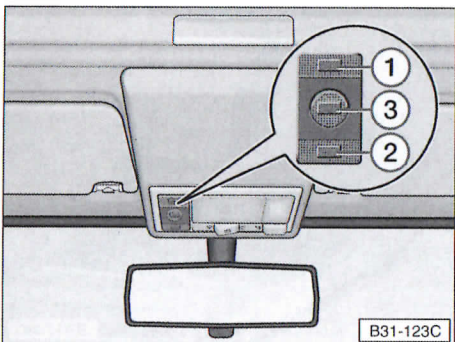

With ignition switched on, the roof can be opened and closed with the switch.

### To open

Press switch **1**.

### To close

Press switch **2**.

### To tilt

Press button **3**.

### To lower

Press switch **2**.

### Notes

- If the roof is open and should be tilted, press button **3** and hold until the function is complete. If the roof should be opened directly from the tilted position, press button **1** and hold until the function is complete.
- When tilting the glass roof, the screen to prevent intensive sunlight shining in will also open automatically with the roof. If required it can be closed by hand when the roof is closed.
- If the sliding roof is open wide and there is a high level of wind noise at high speed, the roof should be closed so far that the noise is eliminated.

### Warning

Care should be taken when closing the roof! Careless or uncontrolled closing of the roof could cause injuries. Therefore, when leaving the vehicle always take the ignition key with you.

### Emergency operation

If the system should develop a fault the roof can also be closed by hand.

- Pull out strip **(A)** around the plastic cover **(B)** in the direction of the arrow.

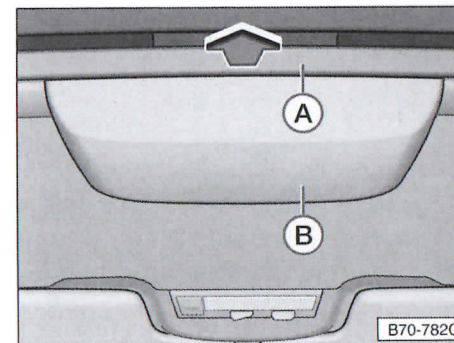

- Carefully press in the two retaining clips (arrow) of the plastic cover **(B)** with the flat blade of the screwdriver until the plastic cover is disengaged.

- Fold plastic cover down.

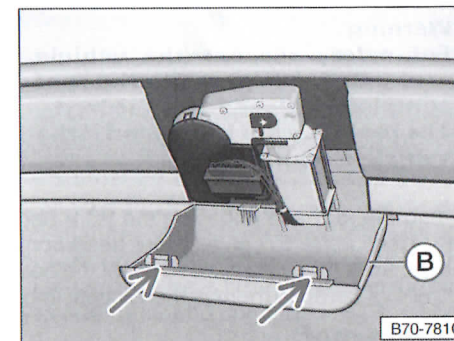

- Turn protective cap **(C)** of crank opening clockwise.
- Pull crank **(D)** out of retainer, insert it in the opening and close sliding roof.
- Replace crank in retainer, and fit protective cap over crank opening.
- Replace cover.

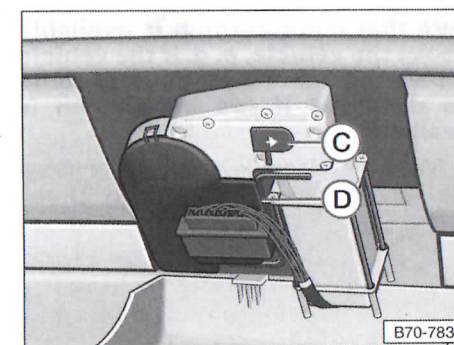



**Pop-up roof\***

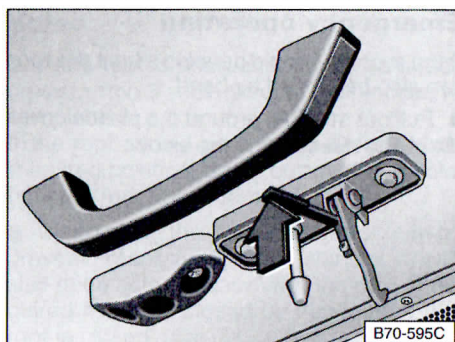
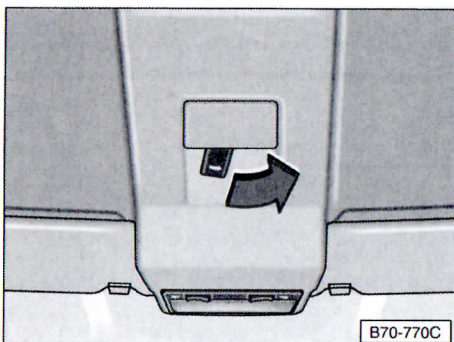

**Warning**  
**For safety reasons the vehicle may only be driven with the roof completely closed and secured. The roof may not be opened if the vehicle is in motion**

- Lift roof slightly until the securing hook is visible.
- Then press lever on securing hook upwards. Then lift the roof as far as possible.

Lifting the roof and engaging the front bed panel (see page 57) gives more headroom inside. After lowering the bed panel the bed in the roof compartment is then accessible.

**Raising roof**

**Before lifting the roof, please ensure that enough room is available above the vehicle, e. g. if the vehicle is parked under trees. The roof could be damaged if too little room is available.**

- Move the release lever in the roof above the windscreen to the direction of the arrow.

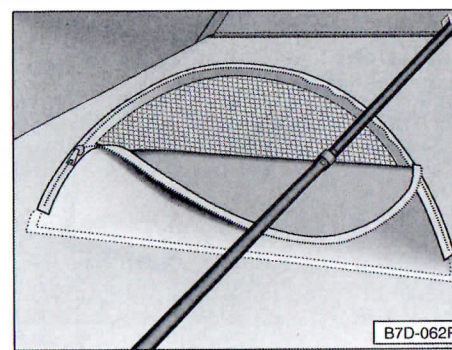
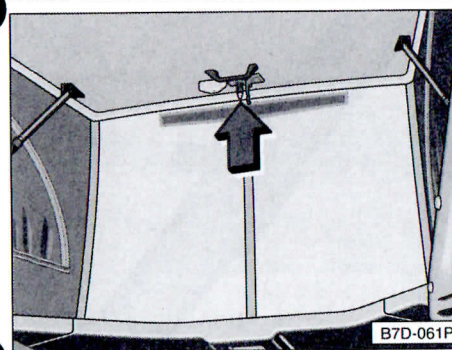

- Then press the roof up (arrow) until the gas struts can hold it open fully themselves. In order to do this, the right-hand gas strut must be engaged fully.

**Notes**

- As the vacuum created when lifting the roof makes it hard to open it is advisable to open a vehicle window or door.
- The roof load must not exceed 15 kg when the roof is open. Please ensure that the gas strut is fully engaged when the roof has been opened. The roof could otherwise close on its own under the weight of the roof load.

**Window in canvas**

Both windows located in the front section of the canvas can be reached after lifting the roof and are screened with gauze for protection against insects.

**Opening window**

Open zip and fold the canvas down. In this position the vehicle can be ventilated without letting insects get into the vehicle. The anti-insect gauze is firmly sewed to the canvas and cannot be opened.

**Note**

When closing the roof, the windows must be closed to avoid damaging the canvas.



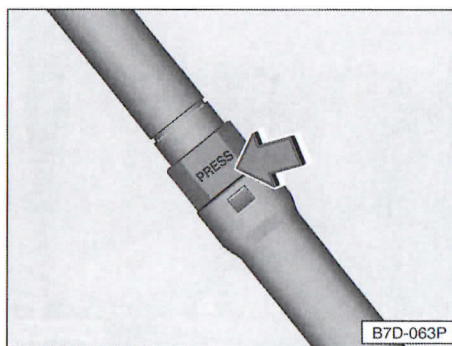
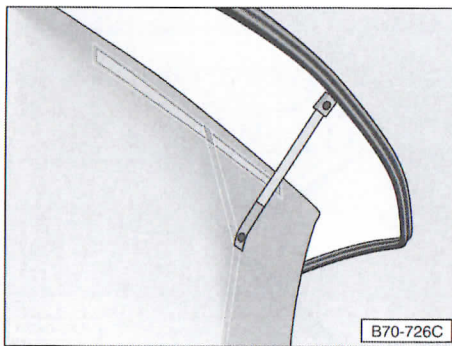

**Closing roof**

**Before closing the roof the bed panel must always be folded down otherwise the roof cannot be closed or could be damaged.**

When closing the roof, the window and insect gauze screen must be closed to avoid damaging the canvas.

Please check regularly that the retaining belt is secured as shown in the illustration. It ensures that the canvas is not trapped in the lock when the roof is closed.

If the retaining belt has become loose, it can be secured as follows:

**On the roof**

Guide the belt through the loop and then secure with the press buttons.

**On the canvas**

Secure the belt to the canvas itself by means of the press button.

There is a red button in the middle of the right hand gas strut with "PRESS" written on it. Press this button to disengage the gas strut and lower the roof at the same time. To lower the roof, take hold of the grip and pull it down slowly.

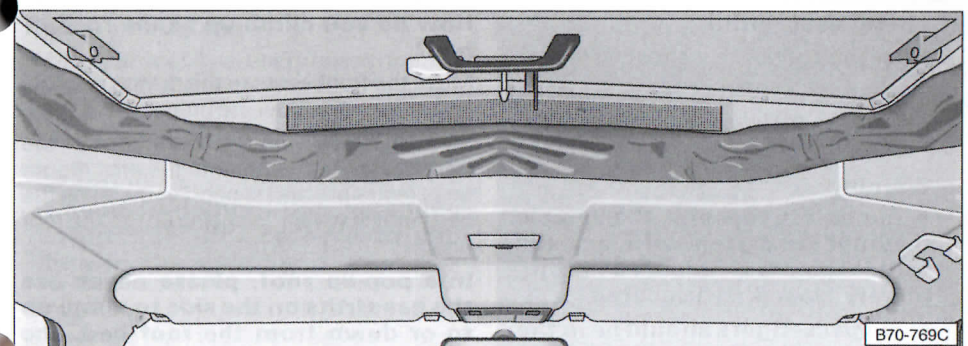

Fold the canvas together and press evenly into the corners until it is taut.

**To prevent damage when closing the roof, the canvas must not get jammed in the catch at front or at the sides between vehicle roof or linkage.**

As the pressure created when closing the roof blows the canvas up and it can get jammed, a vehicle window or door should be opened.

Grasp the handle with both hands and pull roof down with a strong jerk until the lock is heard to engage.

**Warning**  
**For safety reasons the vehicle may only be driven with the roof completely closed and secured.**

In order to prevent the formation of damp stains in the roof canvas the roof should only be closed when dry. If at some time closing the roof when wet cannot be avoided, it should be opened again as soon as possible and allowed to dry.

When the roof is not used for a long time it should be opened from time to time to air it.



## Roof bed\*

### General description

The roof bed offers space for two persons. If small children are to sleep in the roof bed, a safety net which is available from your Volkswagen dealer must be attached.

#### Warning

- For safety reasons, the vehicle may not be driven with a raised roof. The roof must be completely closed and secured.
- No passengers should be in the roof bed whilst the vehicle is in motion.
- If a safety net is not available for the roof bed, small children must not use the bed.

### How do you climb up to the roof bed?

Move the front seats to the driving position and ensure that they are properly engaged.

Step up carefully onto the seat area of the front seat (never step onto the arm rest or head restraint!) and support yourself on the bed surface when "climbing up" to the roof bed.

**In a pop-up roof, please never use the gas struts on the side to climb up to or down from the roof bed. the gas struts could be damaged. It may well be no longer possible to close the pop up roof as a result.**

### What should be noted when climbing down from the roof bed?

In order to avoid personal injury or damage to the interior equipment, please never jump down from the bed onto the seats or the cover. You should climb down carefully. Do not step on the armrests or head restraints!

### Raising bed panel

When the roof has been raised the front section of the bed panel can be swung up and secured on the pop-up roof. This provides more headroom in the living area.

#### Warning

**Check whether the retaining strap is secured properly by pulling on the bed panel.**

Move unlocking button (left-hand illustration) to the right to fold the bed panel down.

**The bed panel must always be swung down before closing the roof otherwise the roof cannot be closed or could be damaged.**

### Removing bed panel

The bed panel can be removed if it is not needed by lifting it out toward the front in folded up state.

**The panel can then be moved to the rear of the bed, but the roof may then not be closed.**

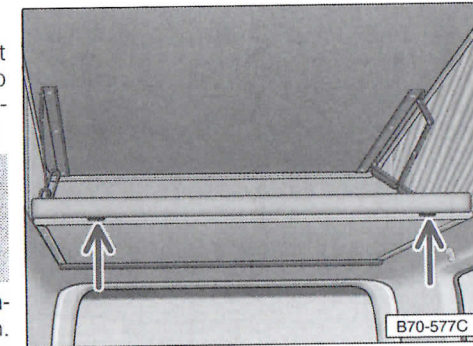

### Installing bed panel

Lift front end of bed panel and insert with the sheet metal tabs in both openings in the bottom of the rear bed section (see illustration). Then lay cushion on bed panel so that the roof can be properly closed.



## Bonnet

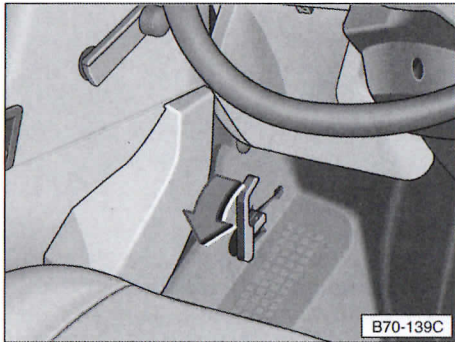

### Unlocking

Pull lever on left under instrument panel – the bonnet springs up out of its lock.

At the same time, a release button will appear in the radiator grille – see right illustration.

**Before opening the bonnet ensure that the wiper arms are not lifted off the windscreen. Otherwise damage could occur to the paintwork.**

### Warning

**Please refer to the warning notes on page 60 before carrying out any kind of work in the engine compartment.**

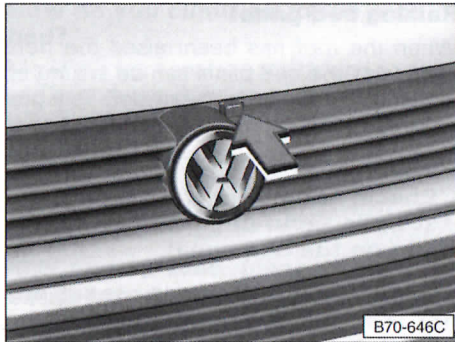

### Opening

Lift the bonnet slightly and push the release button in the direction of the arrow. The catch is thus released.

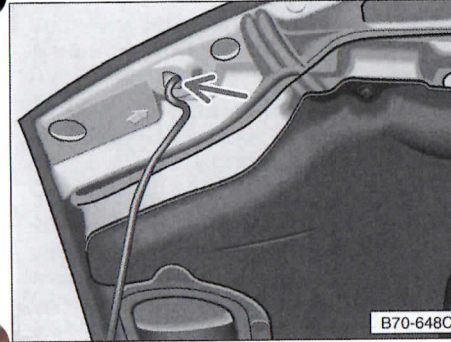

### Opening the bonnet

#### ● Vehicles with support rod

Lift bonnet slightly and then open fully. Take the rod out of the clip and put the end of the rod in the hole provided (see illustration).

#### ● Vehicles with gas support strut

Lift the bonnet slightly and then open to the stop. The bonnet is held in position by a gas filled rod.

### Closing the bonnet

#### ● Vehicles with support rod

Lift the bonnet slightly and unhook the rod. Press the rod into the retaining clip on the front cross panel. Let the bonnet fall into the lock from a height of about 30 cm – do not press it down!

#### ● Vehicles with gas support strut

Hold the bonnet on the side where the gas filled rod is fitted. Press the bonnet down until the gas filled rod gives way and then allow the bonnet to fall into position – do not press down!

### Warning

● For safety reasons the bonnet must always be properly closed when vehicle is moving. Always check therefore after closing the bonnet that the lock is engaged. This is the case when the bonnet is flush with the adjacent body panels.

● If you should notice that the lock is not engaged, stop the vehicle immediately and close the bonnet.



## Safety notes for working in the engine compartment

**Scalding and injuries, risk of fire and accident can occur during all work carried out in the engine compartment, e. g. checking and refilling operating fluids.**

### Warning

Particular care should be taken when working in the engine compartment!

- Never open the bonnet or carry out any work on the engine if you notice that steam or coolant is escaping – risk of scalding! Wait until you can see no more steam or coolant and the engine has cooled down.

- Turn engine off, remove ignition key.

- Pull handbrake firmly on.

- Move gear lever into neutral or "P" position.

- Allow engine to cool off.

- Keep children away from the engine.

- As long as the engine is at operating temperature:

- Do not put your hand into the radiator fan, it could switch on suddenly.

- Do not open the radiator cap because the cooling system is under pressure.

- Never spill any liquids over the hot engine. These liquids could ignite.

- Avoid causing short circuits in the electrical system – particularly at the battery.

- If checks, servicing, repairs or adjustments have to be carried out with the engine running, there is an additional danger present from rotating parts – e.g. V-belts, alternator, radiator fan etc. – and from the high voltage ignition system.

- If work on the fuel or electrics system is necessary:

- Disconnect the battery from the electrics

- Do not smoke

- Never work near naked flames

- Always keep a fire extinguisher in the vicinity.

## Switches

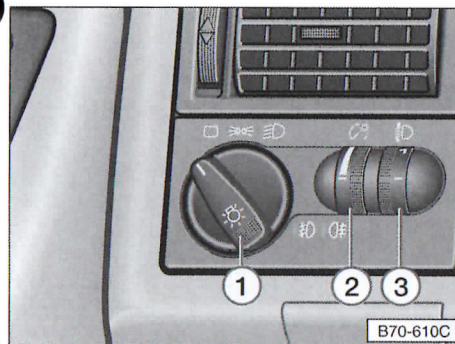

### Notes

- On vehicles with right-hand drive the arrangement of the switches differs. The symbols on the switches are however the same as on vehicles with left-hand drive.

- The use of the lighting described here is subject to local regulations.

### 1 – Light switch



Turn lighting switch to side lights or dipped/main beam position.

 – Switched off

The headlights on vehicles in some export countries will be switched on with reduced output when the ignition is switched on (**daylight driving lights**).

 – Side lights<sup>1)</sup>

 – Dipped or main beam

The dipped/main beam will only work when the ignition is on. When the engine is being started and after ignition has been switched off, the headlights are automatically switched to side lights.

Dipped or main beam or flashing the headlights – see page 64.

<sup>1)</sup> In some countries, when the side lights are switched on with the ignition on, the dipped headlights also come on with reduced intensity.

If lights are not switched off and the ignition key is removed, a buzzer\* will sound when the driver's door is open.

### Front fog lights\*



With lighting switch in side light or dipped/main beam position pull switch out to first detent.

When the fog lights are switched on, the fog light symbol\* next to the light switch lights up green.

### Rear fog light\*



#### Vehicles without fog lights

Turn lighting switch to dipped/main beam position and pull switch out to stop.

#### Vehicles with fog lights

With lighting switch in dipped/main beam position, pull switch out to 2nd detent.

#### Note

- A warning lamp in the combi instrument lights up when the rear fog light is switched on.

- Due to the amount of dazzle it causes, the rear fog light should only be switched on when the visibility is very poor (in Germany 50m, for example).

The electrical system of the factory fitted tow bar\* is wired up so that when towing a trailer fitted with rear fog lights, the rear fog light on the towing vehicle are automatically switched off.



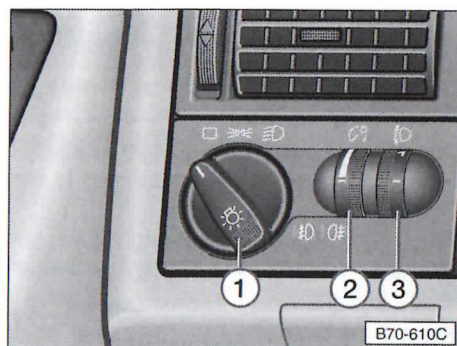

**2 – Instrument and switch lighting**

When the lights are on, turning the knurled wheel on the right of the switch will set the intensity of instrument and switch lighting to any level.

**3 – Headlight range control\***

With the electrical range control the headlight settings can be matched exactly to the load condition of vehicle. This prevents oncoming traffic from being dazzled more than is unavoidable. At the same time the correct headlight beam setting provides the best possible visibility for the driver.

The headlights can only be regulated with the dipped headlights switched on.

To lower the beams, turn knurled disc from the basic position (–) downwards.

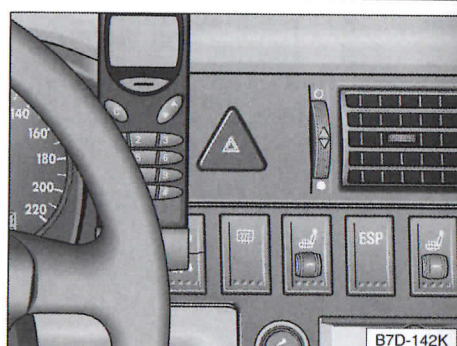

**Hazard warning lights**

The system also works when the ignition is switched off.

Switch on the hazard warning lights if, for example:

- You reach the tail end of a traffic jam.
- You have an emergency
- Your vehicle stops following a technical defect,

When the hazard warning lights are switched on, all four signal lights flash simultaneously. The warning lamps for the indicators and a warning lamp in the switch will also flash.

Note legal requirements when employing such safety measures.



**Roof vent\***

The system also works when the ignition is switched off.

Please always ensure, therefore, that the roof vent is switched off when leaving the vehicle. This will prevent the battery from being used unnecessarily if the vehicle is not used for some time.

**Upper switch – air extraction**

Air extraction is activated by pressing the switch. A lamp lights up in the switch.

The air extraction function can be turned off by pressing the switch again. The lamp goes out.

**Lower switch – ventilation**

Ventilation is activated by pressing the switch. A lamp lights up in the switch.

The ventilation function can be turned off by pressing the switch again. The lamp goes out.



**Roof light\*/  
Rear seat area light\***

The system also works when the ignition is switched off.

Please always ensure, therefore, that the roof light or rear seat area light is switched off when leaving the vehicle. This will prevent the battery from being used unnecessarily if the vehicle is not used for some time.

**1 – Roof light\***

The roof light is switched on by pressing the upper switch. A lamp lights up in the switch.

The roof light is switched off by pressing the switch again. The warning lamp goes out.

**2 – Rear seat area light\***

The rear seat area light is switched on by pressing the lower switch. A warning lamp lights up in the switch.

The light is switched off by pressing the switch again. The warning lamp goes out.



### Turn signal and main beam lever

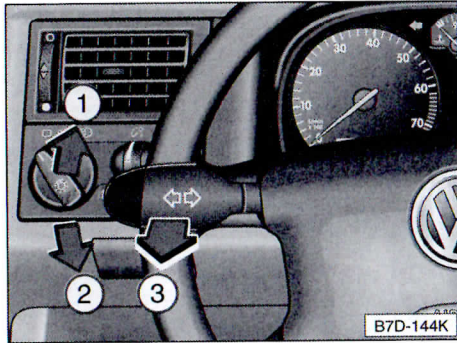

#### Headlight flasher

Pull the lever towards the steering wheel to the pressure point – the main beam warning lamp will light up.

#### Parking lights

The parking lights only work when ignition is switched off.

Right parking lights – lever up (1)

Left parking lights – lever down (2)

If the ignition key has been removed, a buzzer\* will sound when the driver's door is open.

#### Notes

- The use of the signals and lighting described here is subject to local regulations.
- If lights or turn signals are not switched off, and the ignition key has been withdrawn, a buzzer\* will sound when the driver's door is opened.

The turn signals only work when the ignition is switched on.

Right turn signals – lever up (1)

Left turn signals – lever down (2)

When turn signals are working, the appropriate warning lamp flashes as well – see page 21.

The turn signals cancel automatically after completing a turn.

#### To signal a lane change

Move the lever up (1) or down (2) to the pressure point and hold in this position – the warning lamp should flash.

#### Switching main beam on/off

Pull the lever past the pressure point towards the steering wheel (3) with dipped or main beam on. When main beam is on, the main beam warning lamp will light up.

### Interior lights

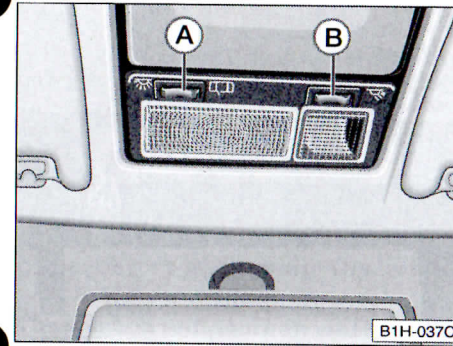

#### Front interior light (A)

- Switch pressed on left – light permanently on
  - Switch in centre position – light off
  - Switch pressed on right – controlled by door contacts
- Interior lights with delayed switch off\* remain on for about 6 seconds after doors are closed.

#### Front reading light\* (B)

- Switch pressed on left – Light off
- Switch pressed on right – light permanently on

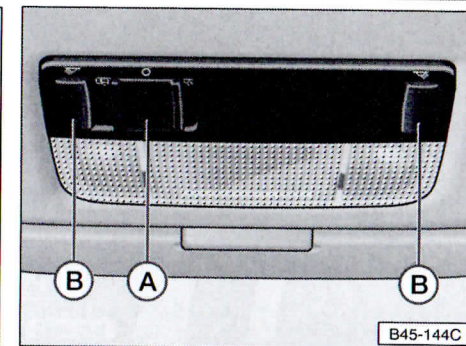

#### Rear interior lights

##### Multivan, Caravelle and Kombi

Switch positions:

- Interior light permanently on. . . . .
- Door contact position
- Off . . . . .



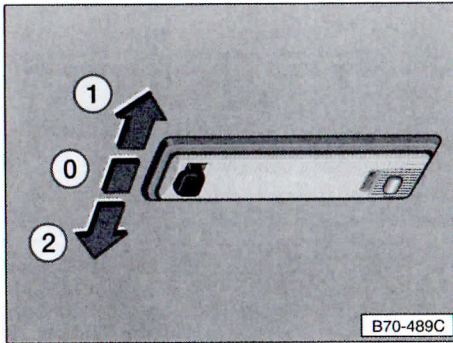

B70-489C

**Rear interior light  
(only Transporters)**

Switch positions:

- 1: Light on continuously
- 0: Off
- 2: Door contact switch

**Entry area light\***

The entry area light of the sliding door is turned on and off by the door contact switch, as long as you do not switch off the light.

To turn off the light press the upper part of the glass.

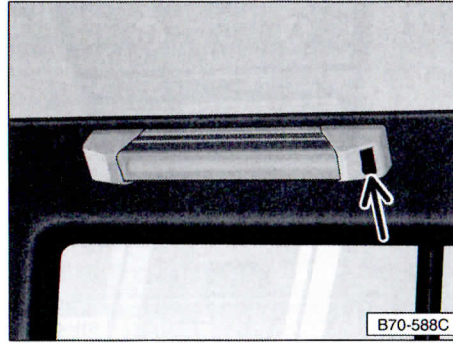

B70-588C

**Transistor light\* (rear)**

The transistor light is switched on and off with the switch (arrow).

The transistor light has a very low current consumption. Despite this, always ensure that the light is switched off when leaving the vehicle or when changing light tubes. This will prevent the additional battery from being drained unnecessarily if the vehicle is not used for some time.

**Glove box light\***

The light in the glove box on the passenger side only comes on when the ignition is on and the lid is open.

**Windscreen wiper and washer system**

**Warning**  
The windscreen wipers must be in very good condition in order to ensure clear vision – see page 69.

Wipers and washers only work when ignition is switched on.

**When it is freezing, check that the wiper blades are not frozen to the glass before switching the wipers on for the first time.**

**The heated windscreen washer jets\*** are switched on when the ignition is switched on and the amount of heat is regulated automatically according to the ambient temperature

**Note**

- Topping up washer fluid – see Booklet 3.2., "Windscreen washer system"
- Changing windscreen wiper blades – see page 69.

**Windscreen**

● **Wipers off**

Lever at position 0.

● **Flick wipe**

Lift lever out of position 0 to pressure point before position 1.

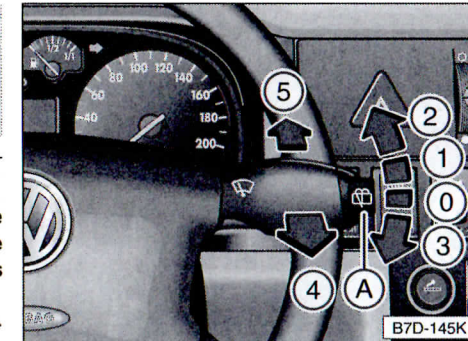

B7D-145K

● **Wiper slow**

Lever at position 1.

● **Wiper fast**

Lever at position 2.

● **Intermittent wipe**

Lever at position 3.

The wipers work about every 6 seconds.

With an **infinitely variable intermittent wipe\*** the wipe delay can be programmed between about 1.5 and 22 seconds:

- Switch on intermittent wipe and wipe once.
- Switch off intermittent wipe and then switch on again after the desired delay.

The selected delay can be changed as often as required. After switching off the ignition the selected pause reverts back to a six second interval.



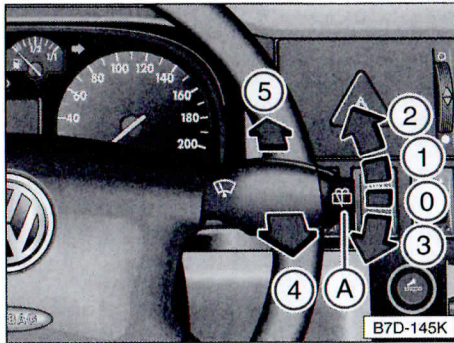

**Rear window**

Press button **A** – the wiper works about every 6 seconds (intermittent wipe). Pressing the button again switches the wiper off.

**Automatic wash/wipe**

Press lever away from steering wheel **5**, and hold in this position – The wiper and washer work as long as the lever is held in this position.

Release lever – The washer stops and the wiper carries on for about 4 seconds.

The wiper/wash system functions at each position **(0–3)**.

● **Automatic wash/wipe facility**

Pull lever towards steering wheel **4** – wipers and washer work.

Release lever – The washer stops and the wipers carry on for about 4 seconds.

The wiper/wash system functions at each position **(0–3)**.

**Headlight washer system\***

When the headlights are on, the lenses are washed every time the windscreen is washed **4**.

At regular intervals such as when filling the tank, caked-on dirt and insects should be removed.

**Windscreen wiper blades**

**Warning**

- **For clear vision, it is imperative that the windscreen wiper blades are in good condition.**
- **In order to prevent streaks on the windscreen, you should clean the windscreen wiper blades regularly with a window cleaner. If the windows are particularly dirty, e. g. insect remains, a sponge or cloth should be used to clean the blades.**
- **For reasons of safety, you should change the wiper blades once or twice a year. Windscreen wiper blades can be purchased at Volkswagen dealers.**

**When it is freezing, check that the wiper blades are not frozen to the glass before switching the wipers on for the first time.**

If the wiper blades judder, it may be caused by various things:

- If the vehicle has been washed in an automatic car wash, residual wax may be left on the windscreen. This residue can only be removed by using a special cleaner. Your Volkswagen dealer will be happy to give you further information.
- Filling the windscreen washer container with a window cleaner containing a wax remover can solve the judder problem. Solvent cleaners cannot remove this residue.
- Damaged wiper blades can also lead to judder. In this case the blades should be renewed.
- The blades are set at an incorrect angle. Have the angle checked and, if necessary, adjusted by a Volkswagen dealer.

**Please also refer to the further notes on next page.**



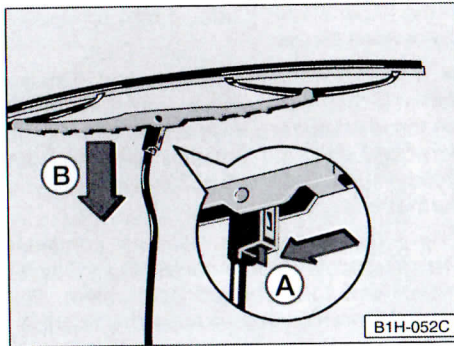

### Changing wiper blades

#### Taking the wiper blade off

- Fold the wiper arm away from the screen and position the blade perpendicular to the wiper arm.
- Press the retaining spring in the direction of arrow **A**.
- Detach the wiper blade in the direction of arrow **B** and then remove from the arm in the opposite direction.

#### Securing the wiper blade

The retaining spring must engage audibly in the wiper arm.

When fitting wiper blades with moulded wind deflectors one should ensure that the deflector is pointing downwards.

### Sun visors

The sun visors can be pulled out of the side mountings and swung towards the doors.

The make-up mirror can also have a sliding cover or cover flap.

On the mirror with light\* the light can, depending on the vehicle model, be turned on:

Either by

- Moving the sliding cover, or
- By raising or lowering the sun visor, or
- Lifting the cover flap.

### Mirrors

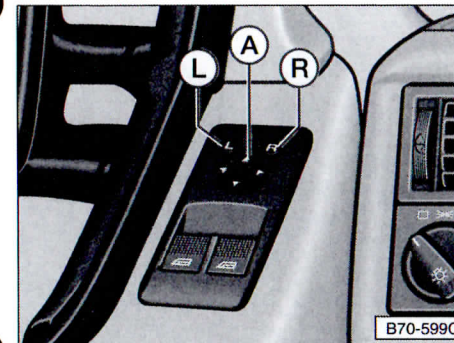

The mirrors should always be adjusted properly before moving off so that good vision to the rear is guaranteed at all times.

#### Adjusting exterior mirrors

**Normal outside mirrors** are adjusted by pressing the edge of the mirror surface.

**Outside mirrors with extended mirror arms** are adjusted by tilting the mirror surface.

**Electrically adjustable mirrors\*** are set by pressing the edge of the knob **A** in the driver's door trim.

By pressing the two upper buttons **L** or **R** switches to the left or right-hand mirror.

If the electrical control of the mirror fails at any time the mirrors can be adjusted manually by pressing on the edge of the mirror surface.

#### Note for vehicles with convex or aspherical outside mirrors \*

**Convex** (curved outwards) mirrors enlarge the field of view but they make objects look smaller. **These mirrors are only of limited use in estimating how far away a following vehicle is.**

**Aspherical** exterior mirrors have a mirror surface with different curvature. This wide-angle mirror increases the area of vision even more so than conventional convex mirrors. **Their usefulness is also limited when judging the distance to vehicles approaching from behind.**

#### Adjusting interior mirrors

The lever on the lower edge of the mirror should be pointing forwards when the basic setting is made.

To set the anti-dazzle position, pull lever to the rear.

**Please also refer to the further notes on next page.**



**Mirror heating\***

**Electrically adjustable mirrors\*** are switched on when the ignition and the rear window heating are switched on and the amount of heat is regulated automatically depending on the ambient temperature.

The heating for the exterior mirror and the rear window is switched off automatically approximately 5 minutes after the rear window heating has been switched on. If necessary, the switch for the rear window heating must be switched off and then back on again.

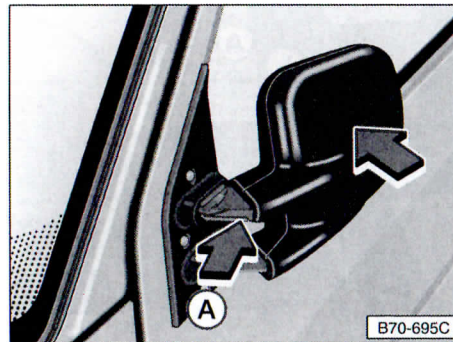

B70-695C

**Folding exterior mirrors back**

**Warning**  
When folding mirror back out ensure that the fingers are not trapped between mirror and bracket – Danger of injury.

Press mirror in towards vehicle, press retainer in (arrow **A**) and fold mirror out.

**Folding exterior mirrors in**

The outside mirrors can be folded in. To do this pull mirror housing towards vehicle until the retainer locates.

**Notes**

- Before putting the vehicle through an automatic washing plant, the mirrors should be folded in to prevent them becoming damaged.
- These remarks apply only to vehicles with normal outside mirrors. Mirrors on extended arms can also be folded in but they have no detent.

**Heated rear window**

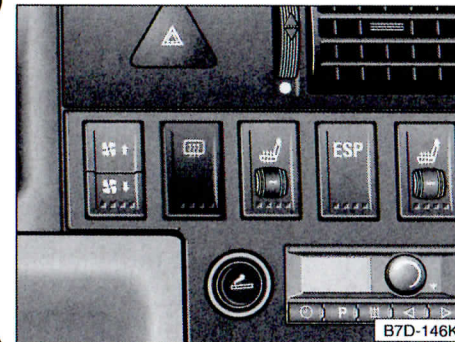

B7D-146K

The heating works only when ignition is on. When heater is on a lamp in the switch lights up.

The heating for the exterior mirror and the rear window is switched off automatically approximately 5 minutes after the rear window heating has been switched on. If necessary, the switch for the rear window heating must be switched off and then back on again.

**Curtains\***

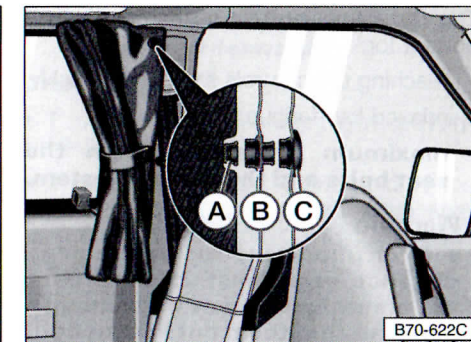

B70-622C

Curtains are available for all windows in the Multivan and are stored in the bag provided. The curtain set consists of four parts, which are buttoned on from inside with press buttons:

- A short curtain for the rear window
- Two of the same length for the rear side windows
- A long one for the windscreen and the two cab side windows. This curtain can be additionally secured over the windscreen by swinging down the two sun visors.

**Securing curtains**

The press stud base (**A**) is attached to the inner trim. The closed stud (**C**) is pressed on to this base.

If the studs of two curtains are to be attached to one base (**A**), first attach the curtain with an open curtain stud (**B**). Then attach the curtain with a closed stud (**C**).



## Front seats

The correct adjustment of the seats is important for:

- reaching the controls safely and quickly
- relaxed low-fatigue body position
- **maximum protection from the seat belts and the Airbag System.**

### Warning

● It is important to maintain a distance of at least 25 cm from the steering wheel or instrument panel so that the front seat occupants will benefit from the greatest possible protective effect of the airbag system should it be triggered. Furthermore, the front seats and head restraints must always be adjusted to suit the body size of the occupant.

Please adjust your seat as detailed on the following pages. Please also note the basic positions for the driver's and passenger seats on this page.

### Warning

No items should be kept in the footwell, as these could block the pedals in the case of a sudden braking or driving manoeuvre.

You would no longer be able to brake, change gear or accelerate!

Feet should remain in the footwell when the vehicle is moving - never resting on the instrument panel or seats.

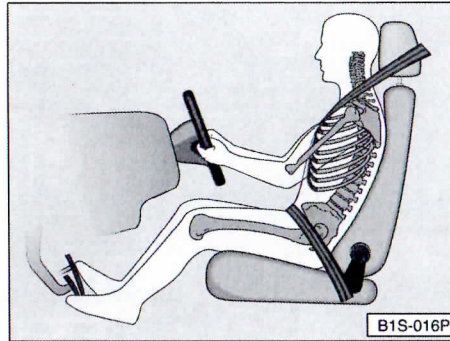

### Driver's seat

We recommend that you position the driver's seat as follows:

- Set the driver's seat forwards/backwards in such a way that the pedals can be fully depressed with a slightly angled leg.
- Set the backrest in such a way that it is fully against your back and that you can reach the upper point of the steering wheel with your arms at a slight angle.

### Front passenger seat

We recommend that you position the front passenger seat as follows:

- Backrest in an upright position.
- Place the feet in the footwell in a comfortable position.
- At the same time push the seat back as far as possible.

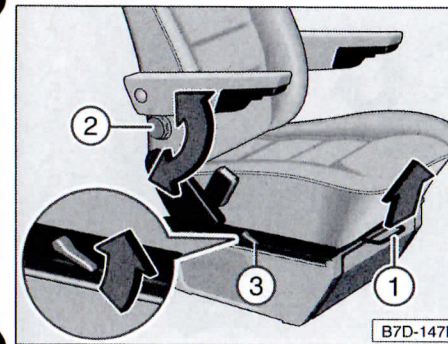

### Driver and front passenger seats

#### 1 - To move front seats backwards or forwards

#### (Range of adjustment for the seats in driving position)

Lift lever and move seat. Then release lever and move seat further so that the catch engages.

### Warning

For safety reasons the driver's seat must only be moved backwards or forwards when vehicle is stationary.

#### 2 - Adjusting lumbar support\*

By turning the hand-wheel the seat padding in the lumbar area of the spine can be made to arch forward slightly. This gives effective support to the natural curvature of the spine so that the sitting position is less fatiguing, particularly on long trips.

#### 3 - Additional adjustments backwards and forwards\*

##### Driver's seat

- Push seat fully forward to the stop by lifting lever 1.
- Then swing up lever 3 and hold in this position. Pull lever 1 up and push seat further forward over the stop all the way and release both levers.

The additional battery\* can now be reached.

##### Front passenger's seat

- Push front passenger's seat fully backward by lifting lever 1.
- Pull up lever 1 and hold it in this position. Push the front passenger seat fully over the detent right to the front.

The brackets for the first aid kit and warning triangle can now be reached.

#### Returning driver's or front passenger's seat to driving position

Pull lever 1 up and hold in this position. Push the seat back at least so far back over the stop that it is in range of driving positions. Release the lever and push the seat further until the lock engages.

### Warning

Both front seats must be locked in driving position when the vehicle is in motion!

Never use the front seats when they are in the range of the additional adjustment!



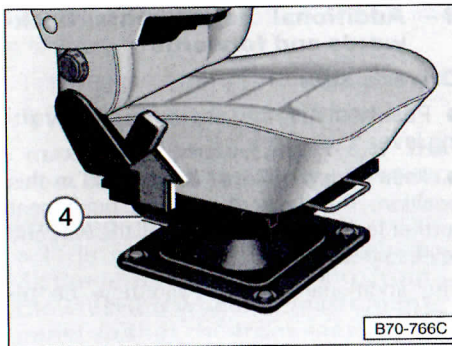

#### 4 – Adjusting pivoting seats\*

Pull lever up at side of the seat and turn seat.

It might be necessary to push the seat forward slightly or open the doors before turning the seats.

##### Warning

- Before rotating the driver's seat the handbrake must first be released. The vehicle must therefore be prevented from rolling by some other method (e.g. gear engaged).
- Before rotating the front passenger seat the handbrake must first be engaged or the vehicle must be prevented from rolling by some other method (e.g. gear engaged).
- When the vehicle is moving the seats must be facing forward and properly secured.

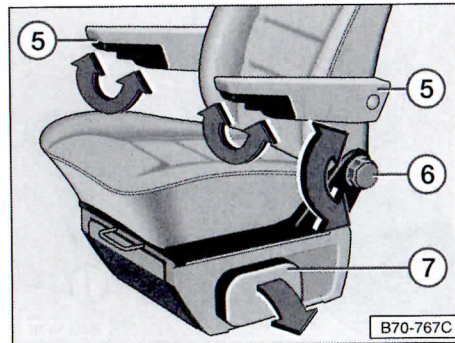

#### 5 – Adjusting armrests\*

The armrests on the front seats can be hinged up if they are not required.

The angle of the armrests can be adjusted as required with a knurled knob, underneath the armrest.

#### 6 – Adjusting backrest

Take weight off backrest and turn knob.

##### Warning

**Do not have the backrest set too far back whilst the vehicle is moving because the seat belts are then no longer fully effective.**

#### 7 – Drinks/can holder\*

The procedure for opening the drinks holder on the passenger side and what should be noted when doing so is detailed on page 104.

### Head restraints\*

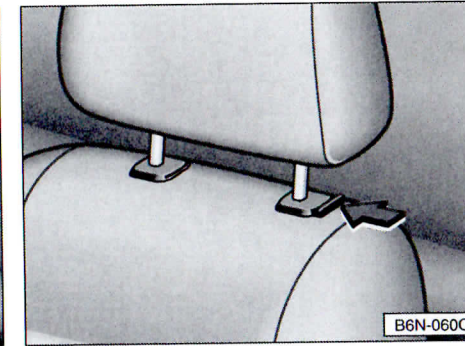
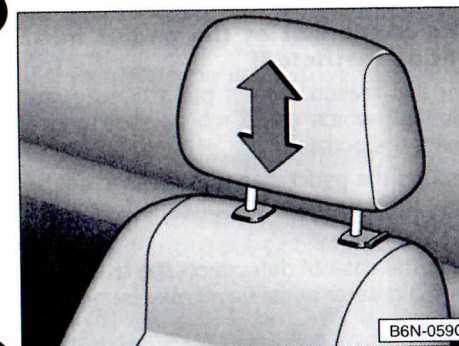

The front and rear\* head restraints are adjustable for height and should be set to suit the size of the person in the seat. Correctly adjusted head restraints, together with properly worn seat belts, offer effective protection.

#### Adjusting height

- Grip sides of head restraint with both hands and pull up or push down.
- The best protection is obtained when the upper edge of restraint is **at least** at eye level.

#### Removing and installing

To remove, pull restraints up to the stop, press button in direction of the arrow and at the same time take restraints out.

To install again, push the restraint rods into the guides until they are heard to engage.

##### Note

On some models, head restraints are fitted which differ from the version illustrated and can be removed and installed as described below.

#### Spring clip version

To remove the spring clips from the seat backrest guide rings, pull or push the clip out to one side with a small screwdriver.

When reinstalling, insert the head restraint first, and then push the spring clips in so that the straight leg is at the rear.



## Seat heating\*



### Knurled wheel for seat heating\*



The cushion and backrest of the front seats can be heated electrically when the ignition is on.

The heating for the front left seat can be adjusted using the left-hand knurled wheel. The heating for the front right seat can be adjusted using the right-hand knurled wheel.

The heating is switched on and regulated with the knurled wheel.

To switch heating off, turn knurled wheel to the basic position (-).

## Pedals

### The movement of the pedals must not be restricted!

For this reason, do not put articles in the footwell which could roll or slide underneath the pedals.

Around the pedal area there should not be any foot mats or other additional floor covering materials:

- In the case of defects on the brake system, a greater pedal travel may be necessary.

- It should always be possible to depress the clutch and accelerator pedals fully.

- All pedals must be able to return, unhindered, to their rest positions.

For these reasons, the only foot mats which may be used are those which leave the pedal area completely free and which are prevented from slipping.

### Warning

**No items should be kept in the footwell, as these could block the pedals in the case of a sudden braking or driving manoeuvre.**

**You would no longer be able to brake, change gear or accelerate!**

## Luggage compartment cover\*

On vehicles with a rear seat bench, a luggage compartment cover can be installed. It is secured to the side trim with a retaining strap.

The cover can be used as a stowage area for articles of clothing.

Please note that the field of vision of the rear view mirror can be obstructed by articles of clothing.

### Warning

**When the vehicle is moving no persons, animals or heavy items of luggage are to be carried on the luggage compartment cover – they are a danger when brakes are applied suddenly or when vehicle is involved in an accident.**

**Furthermore the heating elements of the rear windscreen could be damaged by articles rubbing against them.**

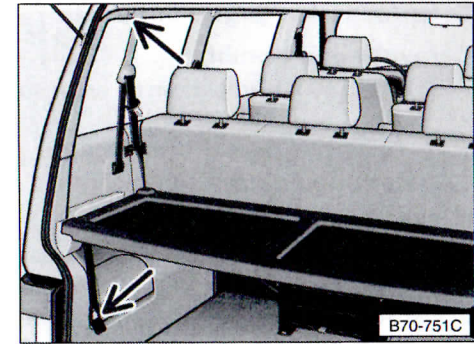

The cover can be swung up and locked in this position to make loading easier.

To do this tip the luggage compartment cover up and lock in position using the retaining strap (arrow).

**The luggage compartment cover must be folded down and secured with the retaining strap whilst the vehicle is in motion (arrow).**

**If the cover is in an upright position whilst driving, the retaining strap anchor and the cover could be damaged.**



## Luggage compartment /load surface

### To enlarge luggage space

#### Caravelle and Kombi

The luggage compartment can be enlarged by:

- Folding bench forwards – see page 101
- Removing seat bench – see page 101.

#### Multivan

- Remove mattress from behind seat bench/sleeping surface.

- Pull the left and right cover panel retainers to rear.

- Remove cover panel.

The seat bench/sleeping surface can also be pushed forwards or removed to enlarge luggage space.

### Notes on loading

In the interests of good handling ensure that the load (persons and luggage) is distributed evenly. Heavy items should always be carried as near to the rear axle as possible or better still, between the axles.

- If a luggage carrier is mounted on the tailgate, observe warning on page 39 before loading the luggage compartment.

- **You must ensure that the heating elements of the rear window are not destroyed by items rubbing against them.**

- Stale air escapes through ventilation openings at the rear.

These openings must therefore not be covered.

In order to avoid damage to the vehicle floor or seat securing elements, please note the following points when loading heavy items:

- **Before loading lay a large, stable underlay across the whole loading area. The weight of the item is thus spread evenly across the whole of the vehicle floor.**

- **If the seats have been removed, you should place the underlay across the seat securing points.**

- **You must not load the vehicle floor heavily in one area.**

- **You should place the items to be transported horizontally in the luggage compartment or on the loading area. They should not be tilted.**

### Warning notes

#### Warning

- **The permissible payloads and GVW must not be exceeded under any circumstances – see Booklet 3.3 .**

- **It should be noted that when transporting heavy items the handling will change due to the displacement of the centre of gravity. Driving style and speed must be altered to suit.**

- **The load must be stowed in such a way that no items can fly forward if the brakes are applied suddenly – use the lashing eyes if necessary.**

- **No persons – including children – should remain in the luggage compartment whilst the vehicle is in motion. Every occupant must be belted in properly – see Booklet 2.1, "Seat belts".**

- **You should never drive with the tailgate or side door slightly or even fully open, as exhaust gases could enter the vehicle!**

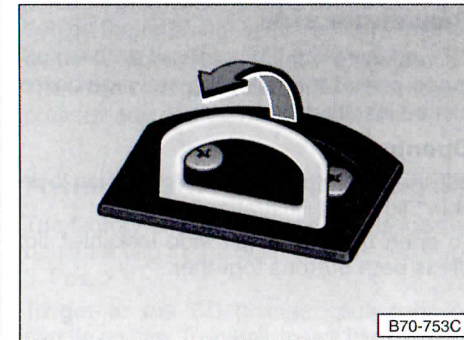
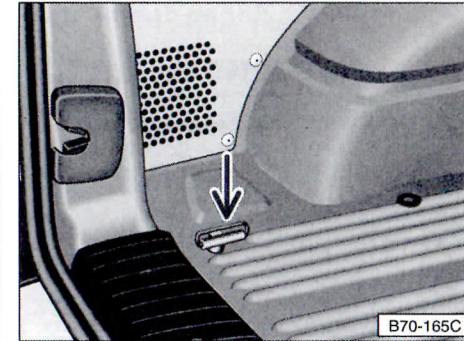

#### Lashing eyes\*

The lashing eyes as illustrated above can be found in the vehicle depending on the model.

On vehicles with lashing eyes the load should always be secured to the eyes.

The lashing eyes comply with the German Standard DIN 75410.

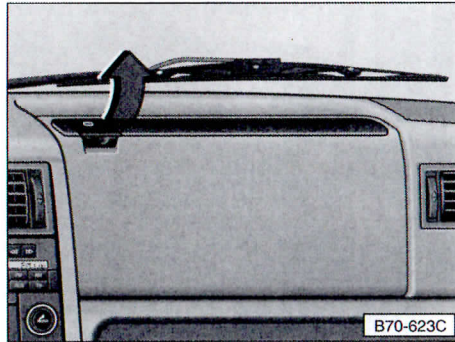

**Stowage box\*****Warning**

**For safety reasons all stowage box lids should always be closed when vehicle is moving.**

**Notes**

This stowage box is intended for the vehicle wallet.

Between the two drinks/can holders in the stowage box there is a holder for coins for parking metres.

**Passenger side**

According to vehicle and scope of equipment, one of the following stowage boxes can be installed.

**Opening**

Lift the catch to open passenger side lockable\* lid – see illustration.

To open the passenger side lockable\* lid, press both buttons together.

**Instrument panel****Warning**

**Never place items on the instrument panel. They could be thrown into the interior of the vehicle whilst the vehicle is in motion (acceleration, driving through curves).**

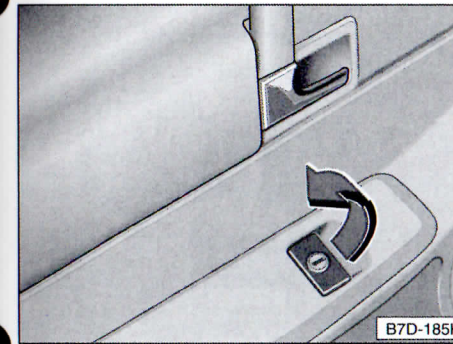
**Stowage area\* in the driver's door**

Lift the catch to open the driver's side lockable\* lid – see illustration.

**Stowage area\* in passenger compartment**

Press the button to open the stowage area (see page 85). The stowage area opens.

Close the stowage area if you want to turn, move or remove the seat in the passenger compartment.

**Waste container\***

The waste container (see page 85) is located in the stowage area of the side trim behind the left hand seat. The container can be used for small quantities of waste.

The lid will open slightly when the button is pressed and can then be opened fully.

**Fitting location of CD changer\***

The factory installed CD changer is located behind a flap in the dash panel – see Page 3, Pos. 23.

To get to the CD changer, pull back on handle on flap. To install, insert flap below in bracket and swing it up until it engages.



## Seats in rear seat area

### Warning notes

#### Warning

When the vehicle is in motion, nobody should be seated on the bench or on the seats in the passenger compartment, unless they are in the driving position so that all passengers can be properly belted in.

Passengers sitting on the sleeping surface or in the luggage area can be hurled forwards in case of an accident or sudden braking – danger of injury!

The sleeping surface or luggage area should therefore not be used to transport people!

The removal or installation of the set bench/sleeping surface or the movable rotating seat is easier if carried out by two people.

Please ensure that you do not damage or dirty any parts when removing and installing the seats or the bench.

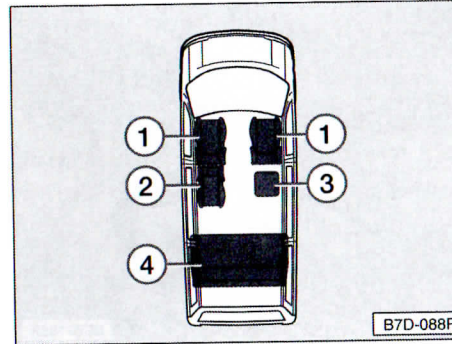

### Seating arrangement in the Multivan

The illustration shows a possible seating arrangement in the Multivan.

#### Driver's compartment

Driver's and front passenger seat

1 - Front seats – as of page 74.

#### Passenger compartment

2 - Movable rotating seat – as of page 88.

3 - Thermal box – as of page 106.

4 - Seat bench/sleeping surface – as of page 86.

The seat railing system in the passenger compartment makes it possible to install the thermal box in the seat runners behind the driver's seat. You will, however, require a special 12 Volt extension cable for the electricity supply.

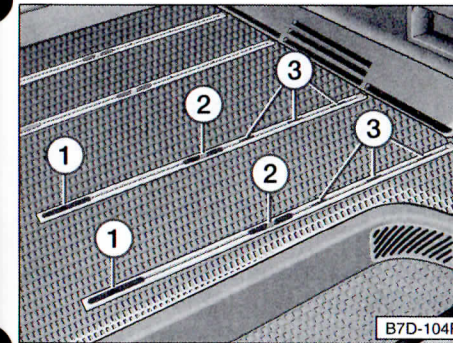

### Seat runners in the passenger compartment

The illustration shows the seat runners behind the right-hand seat.

1 - rear openings with covers

2 - front openings

3 - notch positions.

The openings in the seat runners are used to remove the movable rotating seat or the thermal box from the seat runners or to put them back in again.

The notch positions in the seat runners are used to secure the rotating seat or the thermal box in position.

In order to avoid damage to the rear openings, always install the covers after every removal and installation and then screw the covers down.

**Clean the seat runners regularly. The seat runners and the guiding feet could be damaged as a result of pushing the rotating seats or the thermal box in dirty seat runners.**

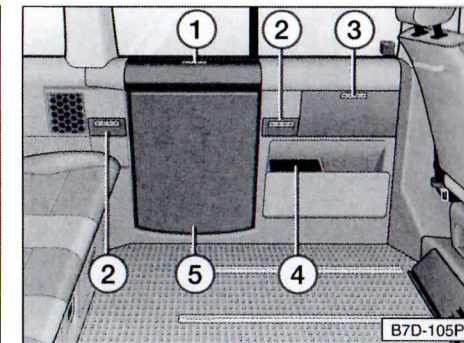

### Overview of interior equipment

The illustration shows the equipment overview of the Multivan in the passenger compartment behind the left-hand seat. The moveable rotating seat (page 88) has been removed for the purposes of the overview.

1 - Drinks/can holder – page 105

2 - Rear ashtray – page 113

3 - Stowage area – page 83

4 - Waste container – page 83

5 - Folding table – page 110



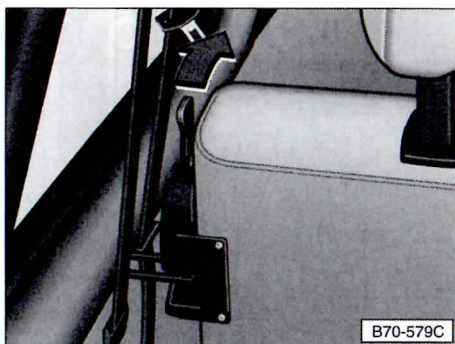

**Warning**

● For safety reasons, the seat bench must always be installed in the runners and properly secured when the vehicle is in motion.

**Folding seat bench into sleeping surface**

Please refer to the warning notes on page 84.

- Fold the folding table down until it engages – page 110.
- Close the ashtray, the stowage area and the drinks/can holder in the passenger compartment.
- Push the rotating seats or the thermal box\* right to the front.
- Remove head restraints.
- Move seat belts out of way:
  - Push rear three-point belts under tab of side trim panel – see left-hand column
  - Push other parts of belt between seat cushion and backrest

**Warning**

● When the bench has been folded into a sleeping surface, nobody, including small children, should be transported in the passenger compartment.

**Seat bench/sleeping surface**

**Folding backrest down**

**Warning**

Before folding the backrest down, the three-point rear seat belt must be pushed under the loop on the side trim panel to prevent it being damaged.

- Push lever next to the head of the backrest forwards in direction of arrow and fold the backrest forwards.

**Folding backrest down**

- Fold back rear seat backrest until it engages. Ensure that the seat belts are not trapped and damaged when folding back.

**Warning**

The rear seat backrest must be properly engaged so that articles in the luggage area cannot slide forward if the brakes are applied suddenly.

**Driving position**

Please refer to the warning notes on page 84.

The seat bench is in driving position (normal sitting position), when you push the seat bench back fully along the runners, adjust the backrest to a vertical position and engage securely.

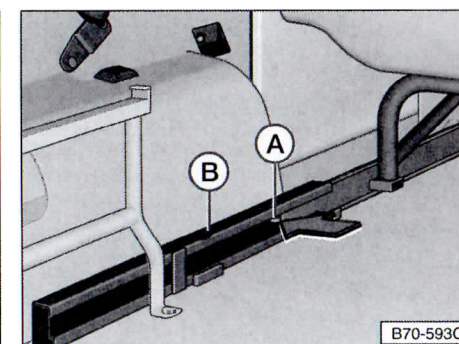
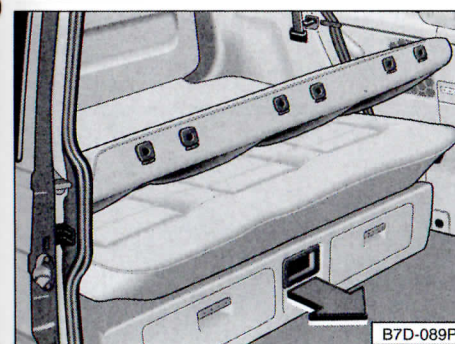

- Disengage backrest and fold down slightly.
- Grip in the recess at the front of the seat bench and pull the seat bench forwards in the direction of the arrow to the stop.

- Fold backrest back to horizontal position in the space created.

**Removing seat bench**

Please refer to the warning notes on page 84.

- Fold the folding table down until it engages – page 110.
- Close the ashtray and the drinks/can holder.
- Remove the thermal box\* (page 106) or the rotating seat (page 88)
- Fold backrest forwards.
- Grip in the recess at the front of the seat, pull seat forward as far as it will go and then push it back slightly.
- Push the release levers **A**, located in the seat/bed guide rails **B**, outwards in the direction of the arrow (the right-hand illustration shows left-hand release lever).
- Pull seat bench to the front and remove from runners.

**Installing seat bench**

- Set seat/sleeping surface in guide rails (**B**), push back to the stop and latch securely.

**Warning**

For safety reasons, when the vehicle is in motion the seat must always be installed in the runners and properly secured.

- Fold back rear seat backrest until it engages. Ensure that the seat belts are not trapped and damaged when folding back.
- Reinstall the thermal box\* (page 106) and the moveable rotating seat (page 88).



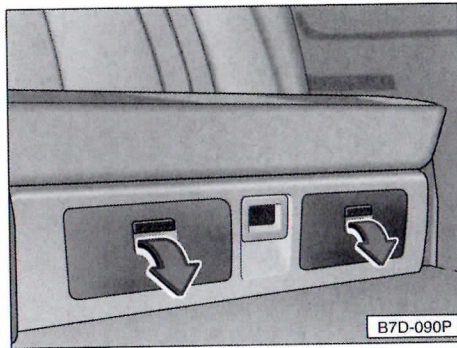

### Through-loading facility

Long pieces of luggage can still be transported with the seat bench installed. To do this, the covers of the seat frames must be removed.

#### Removal

Grip in the recess of the cover and pull it out in the direction of the arrow.

#### Securing pieces of luggage

##### Warning

**The load must be stowed and secured in such a way that no items can slide forward in a sudden braking manoeuvre or in an accident – Risk of injury!**

#### Installation of the cover

Place the cover at the bottom of the opening and fold it up until it engages properly.

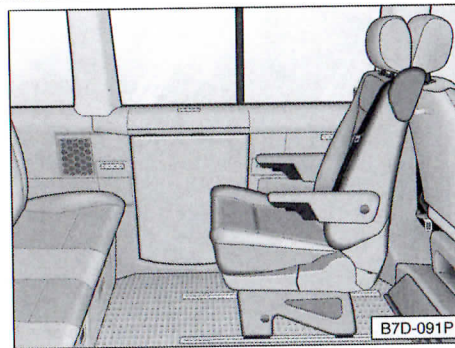

### Moveable rotating seat

The moveable rotating seat must be engaged in the seat runners and securely locked facing either in the direction of travel or opposite the direction of travel (see illustration) when vehicle is in motion.

##### Warning

**When the vehicle is in motion the moveable rotating seat may only be used if it is the driving position and the seat cushion is folded down.**

**It must always be installed in the seat runners and secured so that it does not become a safety hazard when braking hard or in the case of an accident.**

**The seat belt function also depends upon the secure mounting of the seat!**

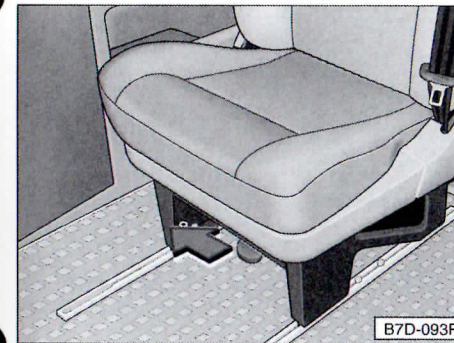

### Turning the moveable seat

- Close the ashtray, the stowage area and the drinks/can holder in the passenger compartment.
- Set backrest against spring loading
- Fold the table down until it engages.
- Press the lever on the front side of the seat to the side and turn the seat in the desired direction at the same time.
- The seat will only engage when you release the lever and the seat is either facing in the direction of travel or in the opposite direction. Please read the notes on the driving position on page 88.

##### Warning

**For safety reasons the seat may only be turned when the vehicle is stationary!**

**The rotating seat may not be used when the vehicle is in motion if it is not in the driving position.**

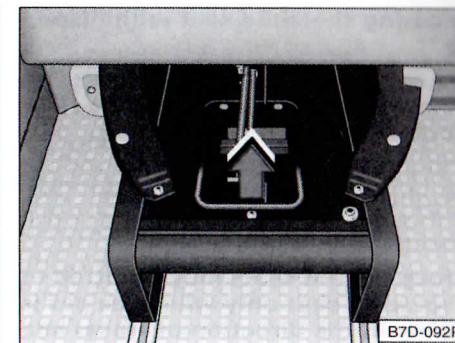

### Moving the rotating seat

- Rotate the seat so that it is in the opposite direction to the direction of travel.
- Fold up the seat cushion. The seat cushion is held up by a gas strut in this position.
- Pull bar on seat frame up in the direction of the arrow and hold it in this position.
- Now push the rotating seat either forwards or backwards in the seat runners.
- Release the bar and push the rotating seat further until it engages securely in the seat runners.
- Carefully fold down the seat cushion. You can only fold down the cushion if the seat is properly engaged.

**Do not sit down on the seat cushion when it is folded up as the seat could otherwise be damaged.**

##### Warning

**There is a risk of crush injuries if the seat cushion is not folded down carefully.**

**For safety reasons the rotating seat may only be moved backwards or forwards when the vehicle is stationary!**



**Securing the child seat with "Isofix"**

Two securing eyes are located between the rear backrest and the seating surface of the moveable rotating seat:

A child seat fitted with the "Isofix" system can be fitted to every rotating seat. Child seats with the "Isofix" system can be purchased at Volkswagen dealers.

**Group 0 child seats may be fitted to a rotating seat only when the set is facing in the direction of travel and securely engaged.**

**For information about properly securing child seats and what to check, see Booklet 2.1.**

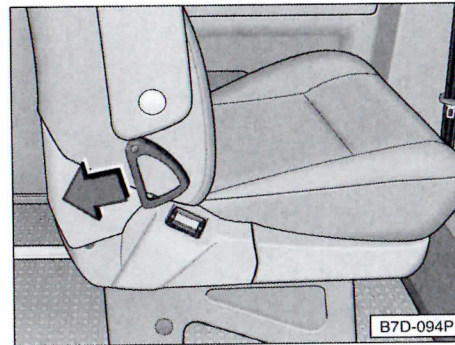

**Adjusting backrest angle (1)**

The illustration shows the moveable rotating seat facing in the direction of travel.

Depending on the setting, the head restraints and the upper edges of the rotating seat and the driver's seat backrests can touch one another. However to ensure that the driver's seat can be positioned properly, preference should be given to the setting of this seat.

The backrest angle of the rotating seat can be adjusted to fixed positions:

- Pull the lever in the direction of the arrow
- Set the backrest against the spring loading
- Release lever and let the backrest engage

**Warning**

**Do not lower the backrest of the rotating seat too far when the vehicle is in motion because the seat belts are then no longer fully effective.**

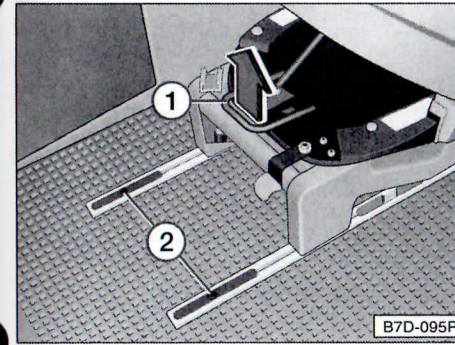

**Removing the rotating seat**

● Close the ashtray, the stowage area and the drinks/can holder in the passenger compartment.

- Fold the table down until it engages.
- Take the covers **2** off the rear openings of seat the runners. The screw must first be removed to do this.
- Fold up the seat cushion
- Pull bar **1** on seat frame up and hold it in this position.
- Slide the rotating right to the rear until the seat can be lifted out of the openings in runners.

**Warning**

**Crush injuries could occur if the seat cushion is not folded down carefully!**

- In order to avoid damage to the seat runners, replace the covers **2** and screw them down.

**Installing rotating seat**

- Close the ashtray, the stowage area and the drinks/can holder in the passenger compartment.
- Fold the table down until it engages.
- Take the covers **2** off the rear openings of seat the runners. The screw must first be removed to do this.
- Set the rotating seat carefully into the runners using the guiding feet. Ensure that the larger guiding feet are placed in the rear openings.
- Push the seat right forward to the stop. The seat must engage securely in the notches.
- In order to avoid damage to the seat runners, replace the covers **2** and screw them down.

**Warning**

The moveable rotating seat must be firmly secured in the mountings and adjusted to one of the driving position after installation so that it does not become a safety hazard when braking sharply or should an accident occur.



Seats in rear seat area (Caravelle/Kombi)

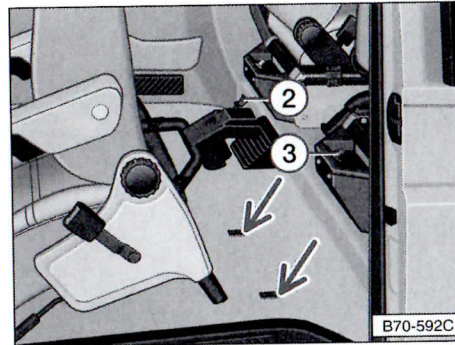

**Single folding seat\***  
(only for right hand drive vehicles)

**Folding seat cushion up (2)**

Pull lever (1) out in direction of arrow and fold seat cushion up (arrow) until it engages.

**Folding seat cushion down**

Pull lever (1) outwards and push seat down until latch engages.

**Removing seat**

Please refer to the general notes on page 93.

- Pull plastic stowage box\* out upwards.
- Hold seat with one hand and push locking lever (2) down with the other – right illustration.
- Twist seat slightly and remove.

**Installing seat**

- Place both seat legs in the grooves in the vehicle floor (arrows in right hand illustration).

- Tilt seat forwards until the latch is heard to engage at the bolt (3).

A visual check and a pull will ensure that the latch is properly engaged.

**Warning**  
Never operate locking lever when seat is occupied. Risk of injury!

**Notes**

- If the backrests of the front seats are tilted a long way back, they may hit the backrests of the folding seats. This can lead to the latch being unable to engage. The front seat backrests should thus be set upright prior to installation of folding seats.
- The securing elements of the single seats are adapted to each individual chair. The seats should, therefore, not become confused.
- Group 0 child seats must not be used on single folding seats.

**General notes**

**Warning**

When the vehicle is in motion, nobody should be seated on the bench or in the seats unless they are in the driving position. The backrest must be properly engaged so that all passengers can be properly belted in.

Passengers sitting on the sleeping surface of the seat bench or in the luggage area can be hurled forwards in case of an accident or sudden braking – danger of injury!

The sleeping surface or luggage area should therefore never be used when the vehicle is in motion!

**Warning**

The following points are important for the safety of vehicle occupants and should be noted when fitting the single folding seat and the single seats:

- The seats must always be properly engaged in the retainers to ensure that it cannot move if the brakes are applied or the vehicle is involved in an accident.
- The seats must always be reinstalled in the correct direction and position. This ensures that the seat belt provided can always be properly used.

Please ensure that you do not damage or dirty any parts when removing and installing the seats.

For this reason, the seats or the bench should always be removed or installed by two people.



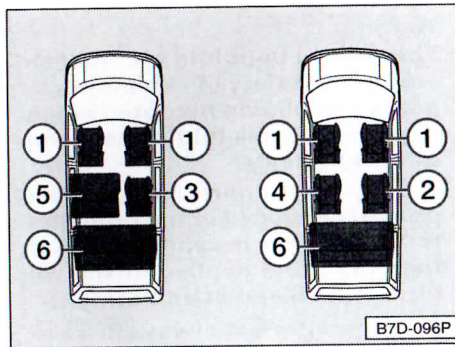

**Seat arrangement  
Caravelle and Kombi**

The illustration shows the seats listed below or of seat benches for vehicles with a short wheelbase.

**Driver's compartment**

Driver's and front passenger seat

1 - Front seats – as of page 74.

**Passenger compartment**

- 2 - Single seat – as of page 95.
- 3 - Folding seat – as of page 96.
- 4 - Rotating seat – as of page 97.
- 5 - Centre seat bench – as of page 98.
- 6 - Rear seat bench – as of page 100.

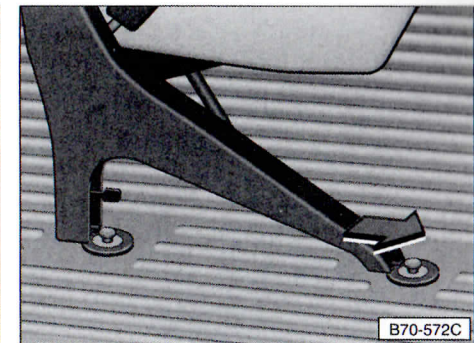
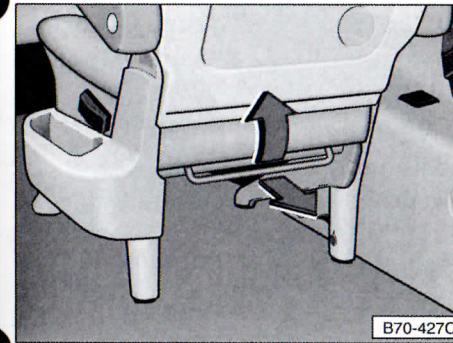

**Single seats\***

Please refer to the general notes on page 93.

**Removing single seat**

**Warning**

**Before removing the single seats you must remove the seat belts from the retainer, so that the belts are not damaged.**

- First bend upper end of belt retainer open slightly (it is located on side of seat) and guide belt strap out retainer.

- Fold backrest down and secure.

Press locking knob on the seat frame and fold backrest downwards until it engages.

- Pull up bar on seat frame up in the direction of the arrow. At the same time pull the seat slightly to the rear (arrow) and then remove.

**Installing single seat**

Please refer to the general notes on page 93.

- To install, place seat in front of securing parts which are anchored to vehicle floor.

- Pull bar on seat frame up and push seat forward until it engages firmly in the securing parts.

- Fold backrest down.

Press the folded down backrest down and hold firmly in this position. Operate the locking knob and fold backrest up until it engages.

- Thread belt strap into retainer again.



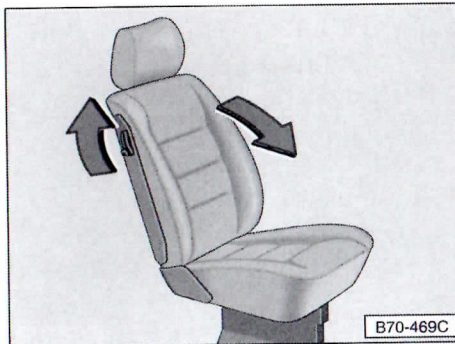

**Folding seat\***

The backrest of the single seat next to the centre seat bench can be folded in such a manner to enable easy access to the rear seat bench.

**Folding backrest down**

**Warning**

**For safety reasons the backrest must always be latched vertically when vehicle is in motion.**

- Unlatch backrest and fold forwards (left-hand illustration).

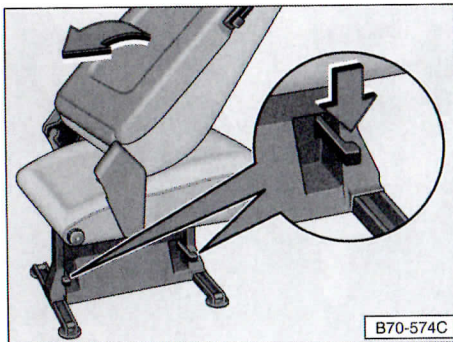

**Removing seat**

**Please refer to the general notes on page 93.**

- Set seat into sitting position.
- Press both levers on base of seat downwards – see illustration above.
- Press seat towards left hand side in direction of seat bench and take out.

**Installing seat**

**Please refer to the general notes on page 93.**

- To install the seat, place seat on left hand side of the securing elements on vehicle floor.
- Press the two levers on base of the seat down and pull the seat to the right until it engages firmly in the securing parts.

**Rotating seat\***

The function of the rotating seat corresponds to that of the rotating driver's and front passenger seat (see page 75)

**Group 0 child seats may be fitted to a rotating seat only when the seat is facing in the direction of travel and securely engaged.**

**For information about properly securing child seats and what to check, see book 2.1.**

**Warning**

**When the vehicle is moving the rotating seats must be facing forward and properly secured.**

**Removing seat**

**Please refer to the general notes on page 93.**

- Remove the covers from the four bolts.
- Remove the four bolts and remove seat (arrows in diagram indicate the two left bolts).
- Screw in and tighten all four bolts in the securing points.
- Replace the covers on the bolts.

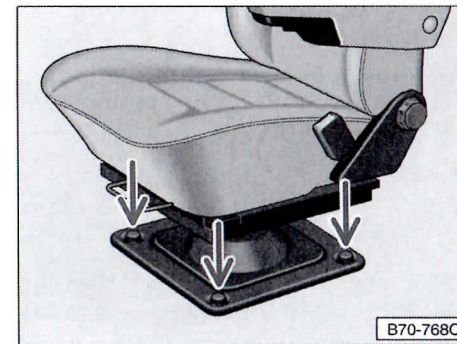

**Installing seat**

**Please refer to the general notes on page 93.**

- Remove the covers from the four bolts.
- Remove the four bolts.
- Place the seat over the securing points in such a way that all four bolts can be screwed into the securing points.
- Then tighten all four bolts.
- Replace the covers on the four bolts.

**Warning**

**Always ensure that that the rotating seat securing bolts are tightened fully again.**

**The security of the seat belts and therefore the safety of the passengers depends upon it.**

**Please have the tightening torque of the securing bolts checked by a Volkswagen dealer after the seat has been installed.**



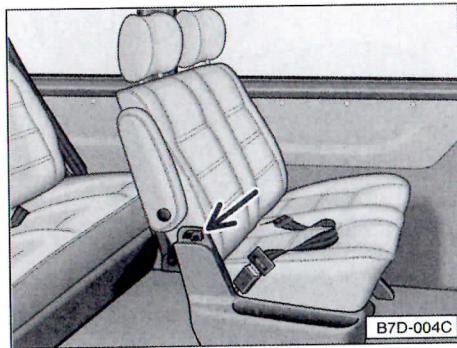

**Folding backrest down**

Press the folded down backrest down and hold firmly in this position. Operate the locking knob and fold backrest up until it locates. The backrest is latched vertically in this position.

**Securing the child seat with "Isofix" fittings**

Two securing eyes are fitted to each seating place on the centre seat bench (between the rear backrest and the seating surface). You can secure a child seat using the "Isofix" system. Child seats with the "Isofix" system can be purchased at Volkswagen dealers.

**Centre seat bench**

Child seats equipped with the "Iso-Fix" system can be secured to this seat bench.

**Driving position**

**Please refer to the general notes on page 93.**

The seat bench is in the driving position when the bench is engaged fully in the mountings in the floor. The backrest must also be latched vertically – see the illustration above.

**Folding backrest down**

Press locking knob (arrow) to rear and fold backrest downwards. When folded down the backrest is engaged and locked.

**Warning**

**For safety reasons the backrest must always be latched vertically when vehicle is in motion.**

**Warning**

**● A child seat may only be used on the centre seat bench if the seat bench is in the driving position and the backrest is fully secured in the upright position.**

**● The seat bench must always be installed in the runners and secured so that it does not become a safety hazard in a sudden braking manoeuvre or in the case of an accident. The seat belt function and that of the child seat also depend upon the secure mounting of the seat!**

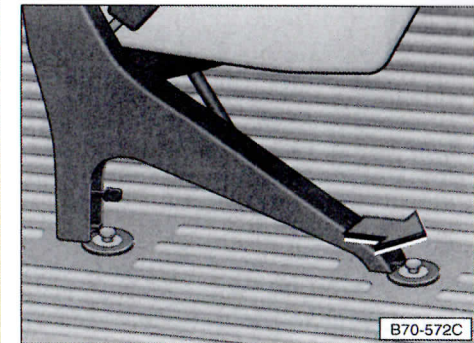
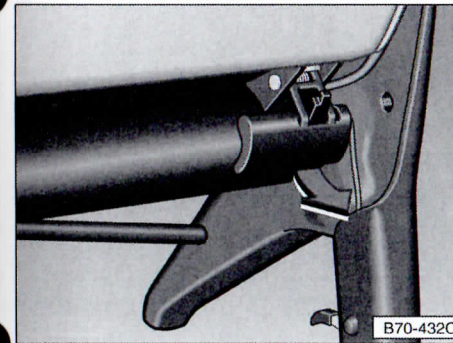

**Removing seat bench**

**Please refer to the general notes on page 93.**

- First bend upper end of belt retainer open slightly (it is located on the side of the seat bench) and guide belt strap out of retainer.
- Fold and latch backrest down.
- Whilst operating the right grip (see illustration) pull the right side of the seat bench back slightly at the same time. Repeat this procedure for the left side of the seat bench and then remove the bench.

**Installing seat bench**

**Please refer to the general notes on page 93.**

- To install, place seat bench in front of the securing parts in floor as shown in illustration.
- Lift grips on left and right of seat bench frame and push forward until it engages firmly in the securing parts.
- Thread belt strap into retainer again.

**Warning**

**When installing the bench seat the following points are important for the safety of the vehicle occupants:**

- **The seat bench must always be firmly engaged in the mountings so that it cannot become detached when braking or in an accident.**
- **The bench must always be installed in the correct direction and position so that the belts provided for each place can be worn properly.**



**Rear seat bench**

**Warning**

Before folding the backrest down, the three-point rear seat belt must be pushed under the loop on the side trim panel to prevent it being damaged.

**Driving position**

Please refer to the general notes on page 93.

The seat bench is in the driving position when the bench is folded back and engaged securely in the mountings on the floor. The backrest must also be folded back and engaged securely.

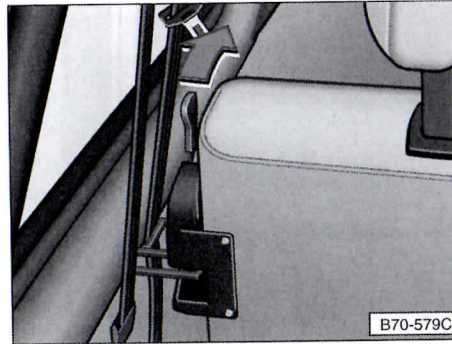

**Folding backrest down**

- On vehicles with rotating single seats\* first remove the head restraints on the seat bench so that they do not hit the single seats (see page 77).
- Push lever next to the head of backrest forwards in direction of arrow.
- Fold backrest forwards.

**Folding backrest down**

- Fold back rear seat backrest until it engages properly. Ensure that the seat belts are not trapped and damaged when folding back.
- Reinstall the head restraints in the seat bench (see page 77).

**Warning**

The rear seat backrest must be properly engaged so that articles in the luggage area cannot slide forward if the brakes are applied suddenly.

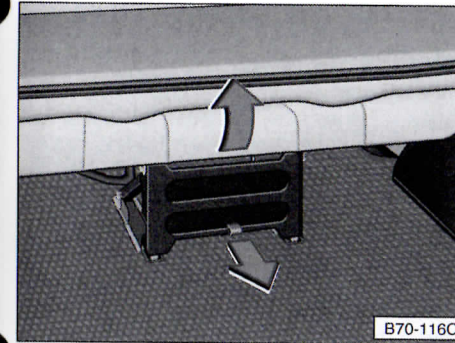

**Tipping seat bench**

- Fold backrest forwards.
- Swing luggage compartment cover\* forwards onto backrest.
- Pull loop on lower part of seat bench
- Tip bench forwards.

**Tipping seat bench back**

Tip the bench back carefully. Please ensure that no items are caught up or damaged when folding back.

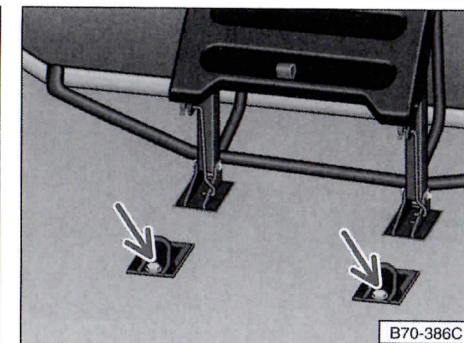

**Removing rear seat bench**

Please refer to the general notes on page 93.

- Fold backrests of centre seat bench and folding seat\* forwards
- Pull seat frame trim\* off forwards
- Remove head restraints and fold backrest forward
- Tilt the luggage compartment cover\* forward onto the backrest and fold the bench forward
- Loosen and remove the two rear bolts (upper illustration) using the vehicle tools.
- Carefully fold seat back
- Fold back carpet\* to attain access to the front bolts



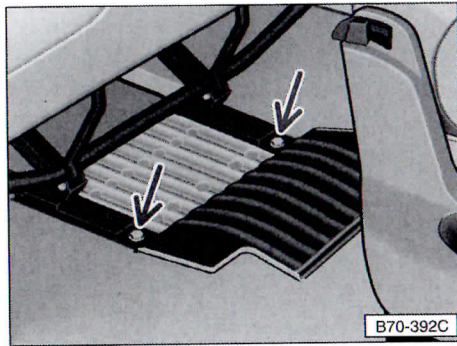

- Loosen and remove front bolts (arrows in right-hand illustration) using the vehicle tools.
- Remove seat to rear
- Screw in and tighten all four bolts in the securing points.

#### Fitting rear seat bench

Please refer to the general notes on page 93.

- Fold backrests of centre seat bench and folding seat\* forwards
- Fold back carpet tabs\* and remove the four bolts.
- Fit seat into correct position and screw in front bolts hand tight.
- Carefully fold seat forward
- Insert rear bolts and tighten all four bolts

- Carefully fold seat back
- Fold back luggage compartment cover\*.
- Fold back rear seat backrest until it engages. Ensure that the seat belts are not trapped and damaged when folding back.
- Reinstall the head restraints in the seat bench (see page 77).

#### Warning

Ensure that the rear seat bench securing bolts are tightened again.

The security of the seat belts and therefore the safety of the passengers depends upon it.

Please have the tightening torque of the securing bolts checked by a Volkswagen dealer after the seat bench has been installed.

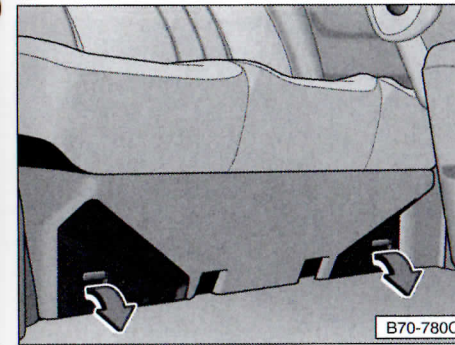

#### Rear seat bench (Double cab)

##### Stowage area under the seat cushion

The space under the seat cushion can be used for stowage purposes. Unlatch the cushion with the locking lever, fold up and hold in the open position.

When closing, ensure that the cushion engages securely in the retainers and that no articles in the stowage space are trapped under the seat.

#### Warning

● For safety reasons, when the vehicle is in motion the seat must always be firmly secured.

● Furthermore, when the vehicle is in motion, nobody, including small children, should be outside the seating areas. All passengers should be correctly belted in.

#### Through-loading facility

Long pieces of luggage can still be transported with the seat bench installed. To do this, the overs of the seat frames must be removed.

#### Removal

Grip in the recess of the cover and pull it out in the direction of the arrow.

#### Securing pieces of luggage

#### Warning

The load must be stowed and secured in such a way that no items can slide forward in a sudden braking manoeuvre or in an accident – Risk of injury!

#### Installation of the cover

Place the cover at the bottom of the opening and fold it up until it engages properly.

#### Removing seat cushion

Please refer to the warning notes on page 84.

● Unlatch seat cushion, fold it up and pull it forwards to the stop. Lift left-hand side of cushion so that the guide rod is beneath the seat frame. Lift out the opposite side of the cushion and pull the seat cushion out at an angle.

#### Installing seat cushion

Install in the reverse sequence.



**Drink / can holder\***

**Warning**

Do not put any hot drinks, e.g. hot coffee or tea, in the drinks/can holder whilst the vehicle is in motion. The hot drink could spill in the case of an accident or sudden braking manoeuvre and this could cause scalding.

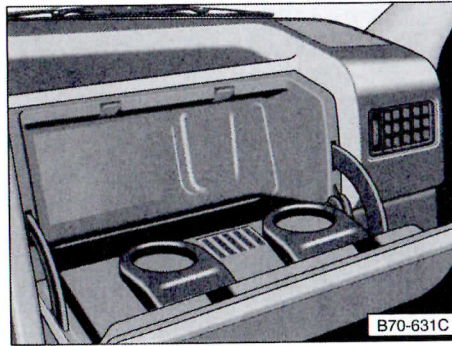

**In the stowage box flap**

The illustration shows the drink can holder on the inside of the stowage box flap in the opened position.

**Warning**

For safety reasons all stowage box lids should always be closed when vehicle is moving.

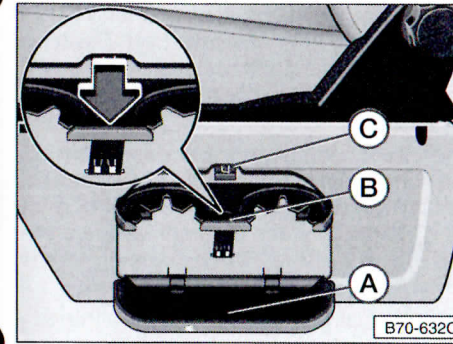

**Next to passenger seat\***

**To open** - Fold the base **A** of the drink holder downwards. Then fold the rings upwards.

**To close** - Press the drink holder rings **B** down in direction of arrow until it engages. Then fold the base **A** up.

If the rings **B** are pressed in direction of arrow, the drink holder can also be used to hold larger or square containers. The rings fold up automatically when the button **C** is operated.

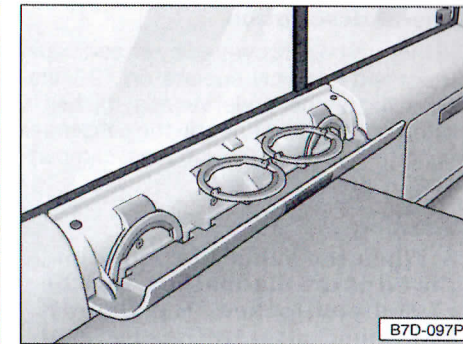

**In the passenger compartment\***

The illustration shows both of the middle drinks/can holders in the open position.

**To open** - Fold the cover of the drink holder downwards – see illustration. Then fold ring upwards.

**To close** - Remove your drink. Then press the drink holder ring downwards and then the cover upwards until it engages.

**Note**

Please close the holder if you are moving or removing the rotating seat or rear seat bench.



## Thermal box\*

### General description

The thermal box is powered by an additional battery and can only operate on 12 Volts. Depending on the model version, the box is located in the seat runners in the passenger compartment or in the luggage compartment.

#### Warning

● **When the vehicle is in motion, the lid of the thermal box must be closed and locked. The thermal box must also be in the seat runners and be securely engaged in the driving position.**

● **If the thermal box is to be transported without being installed (e.g. in the luggage compartment), the lid must be closed and locked. Furthermore, you must secure the thermal box so that it does not become a safety hazard during an accident or braking manoeuvre.**

The box works almost completely independent of incline and without the engine being switched on. A battery monitor integrated in the lid ensures that the battery will always be able to start the engine.

The battery monitor will switch off the thermal box automatically if the voltage of the additional battery falls below 11.5 Volt. The thermal box will switch back on automatically once the battery voltage has reached 12.8 Volt.

It is possible to keep drinks and food either cool or warm in the thermal box. The thermal box has a capacity of approx. 32 litres. The power consumption is approximately 33 Watt.

The interior temperature is dependent on the surrounding temperature of the thermal box. When cooling it can be a maximum of 20 °C lower than the ambient temperature and 35 °C above when keeping items warm.

The thermal box will switch off automatically if the interior temperature reaches approx. 65°C.

**Please do not place any items of clothing or any other articles on the cooling/warming unit of the thermal box. The intake opening could be blocked and switch off the box as a result.**

The runner system in the passenger compartment also makes it possible to position the thermal box behind the driver's seat.

You might, however, need a special 12 Volt extension cable for the power supply.

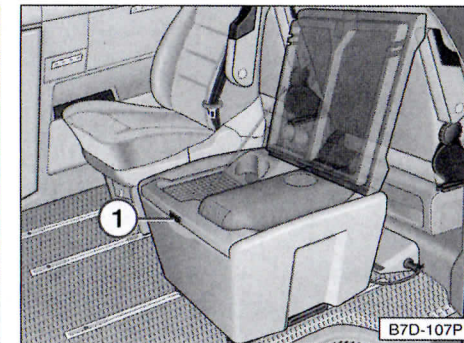
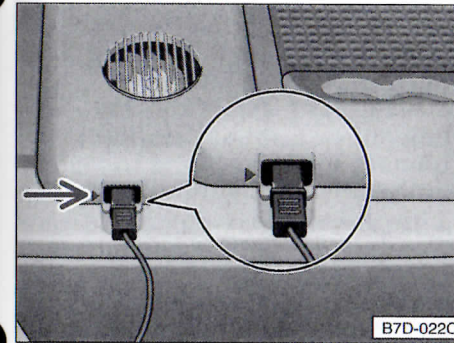

### Refrigerating

**If the surrounding temperature of the thermal box is low, the interior temperature could fall below +2°C when refrigerating. The items in the thermal box could freeze!**

- Place the extension cable plug in the socket of the thermal box so that the blue marking on the cable points to the notch – see illustration.
- The electricity supply is then set up by putting the plug into the 12V socket.

### Warming operation

**The containers and contents that you place in the thermal box may be no warmer than 50°C. The warming unit of the thermal box could otherwise be damaged. The containers will also become hot.**

- Place the extension cable plug in the socket of the thermal box so that the red marking on the cable points to the notch – see illustration.
- The electricity supply is then set up by putting the plug into the 12V socket.

### Opening and closing the lid

#### Warning

● **Always close the lid of the thermal box before driving. The lid could fall shut and possibly cause injury if the car stops suddenly.**

● **Whilst the vehicle is in motion, the lid of the thermal box must, for safety reasons, always be closed and locked.**

#### Opening

- Press the lock **1** on the lid to the front.
- Lift the lid of the thermal box. When fully opened, the lid will be held in position by a support – see illustration.

#### Closing

Fold down the lid of the thermal box until it is fully engaged.



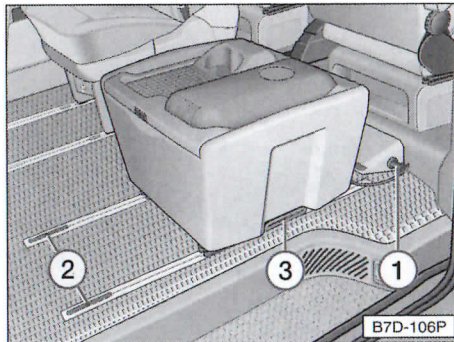

### Removing refrigerator

- Close the lid of the thermal box.
- Disconnect the cable by pulling the connector **1** out of the 12 Volt socket.
- Take the covers **2** off the rear openings of seat the runners. The screw must first be removed to do this.
- Disengage the thermal box. To do this, press down both of the levers **3** on the sides (the illustration shows the right hand lever). Hold the levers in this position.
- Slide the box to the rear until it can be lifted out of the openings in runners.
- In order to avoid damage to the seat runners, replace the covers **2** and screw them down.

### Warning

- **When the vehicle is in motion, the lid of the thermal box must be closed and locked. The thermal box must also be in the seat runners and be securely engaged in the driving position.**
- **If the thermal box is to be transported without being installed (e.g. in the luggage compartment), the lid must be closed and locked. Furthermore, you must secure the thermal box so that it does not become a safety hazard during an accident or braking manoeuvre.**

The runner system in the passenger compartment also makes it possible to position the thermal box behind the driver's seat.

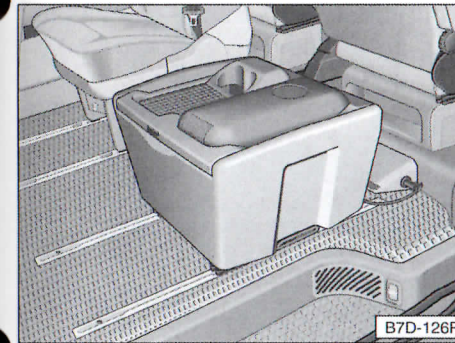

### Installing the thermal box

The illustration shows the thermal box in driving position. The box can only engage securely in the seat runners if it is the driving position.

The box cannot be secured properly in the seat runners if it is installed in the opposite direction to the direction of travel.

- Place the thermal box in the openings in the seat runners and push the box to the front. The box must engage properly..
- Place the plastic covers in the openings of the seat runners and screw them down.
- Reconnect the electricity if required.

### Warning

**The thermal box must be in the seat runners after installation and be securely engaged in the driving position so that it does not become a safety hazard when braking sharply or during an accident occur.**

### Notes and tips when using the thermal box

- The lid of the thermal box should always be kept firmly closed when the unit is switched on, so that it does not overwork.
- Keep the lid open when the thermal box is not being used so that mold and damp stains cannot develop.

- Food and drinks should only be placed in the refrigerator in tightly sealed containers whenever possible.
- The containers should also be as small as possible, as it is easier to stow many small containers than a few large ones.
- The box should also not be packed too full in order not to impair the circulation of cooling air.
- Rattling noise from the thermal box can be avoided by placing slightly crumpled paper between bottles and other containers.

### Operating faults

If the thermal box should not work, please refer to the following help measures:

- Have the battery charge condition checked, if necessary charge the battery by running the engine. The thermal box will start automatically once a sufficient voltage has been reached.
- Check the fuses, change if necessary. The fuse of the battery monitor in the lid should only be checked and changed by a Volkswagen dealer.
- Check if the connecting cable is connected correctly to both the 12 Volt plug and the thermal box.

If these individual remedies do not meet with success, your Volkswagen dealer will be pleased to help.



## Folding table in the Multivan

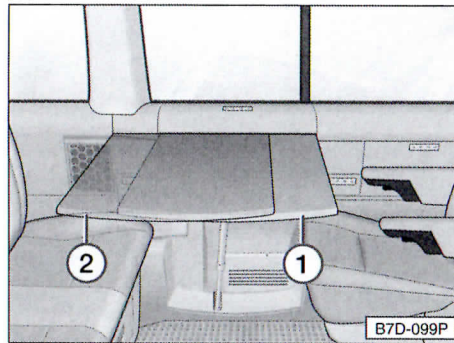
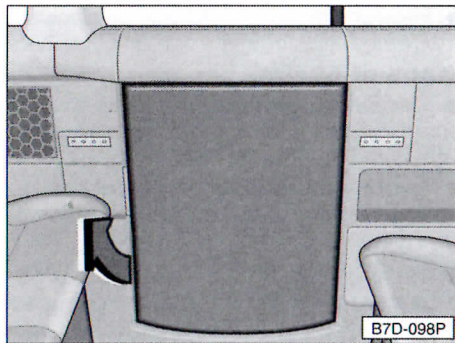

### Setting up the folding table

The sleeping surface/seat bench must first be placed in the driving position before setting up the folding table. The moveable rotating seat must be right at the front of the seat runners and be engaged in the opposite direction to the direction of travel. The folding table will otherwise hit the seat cushion and cannot be folded up.

- Pull the folding table out of the retainer in the direction of the arrow. Then swing the table up until the support strut engages securely.

When using the folding table, it must, for reasons of safety, be engaged in the original or convenience position.

#### Warning

**The folding table should not be erected when the vehicle is in motion as it could cause injuries in case of an accident or sudden braking!**

**For this reason, the table must be folded down and properly secured when the vehicle is on the road.**

### Folding table positions

- 1 - Original position
- 2 - Convenience position

In order to increase the comfort of the passengers on the seat bench, you can push the folding table to the rear once it has been set up.

Please note that the folding table can only properly engage in the original or convenience position.

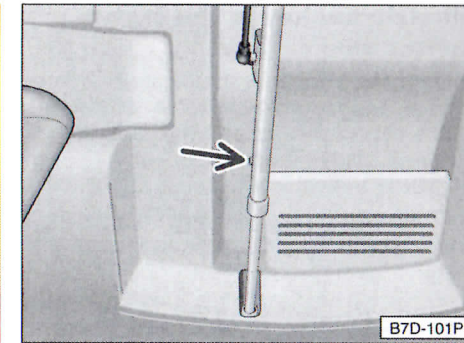
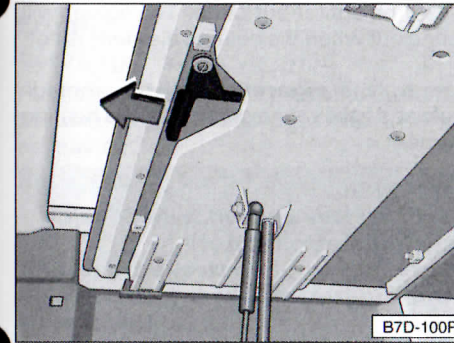

### Moving folding table

There is a disengaging lever underneath the table (see illustration).

**In order to avoid damage to the side trim or the folding table, the folding table may only be moved when it is the fully upright position.**

### Moving to the convenience position

Pull the disengaging lever to the rear in the direction of the arrow and hold the lever in this position. Push the table fully to the rear and release the lever. The table must engage properly in the convenience position.

### Moving to the original position

In order to return the table to the original position, pull the disengaging lever to the rear and hold the lever in this position. Push the table right to the front and release the lever. The table must engage properly in the original position.

### Folding down the table

**In order to avoid damage to the side trim or to the folding table, the table may only be folded back down in the original position.**

The seat bench/sleeping surface must be in the driving position before folding down the table. The moveable rotating seat must be right at the front of the seat runners and engaged in the opposite direction to the direction of travel. The folding table will otherwise hit the seat cushion and cannot be folded down.

- Move the table back to the original position until it engages properly.
- Lift the table slightly until the knob (arrow) on side of table support strut can be pushed in.
- Swing the table down. Press on the table lightly until it engages in the retainer.



## Electric sockets

### Electric socket in the instrument panel

The 12 Volt socket in the cigarette lighter can be used for other electrical accessories with a capacity of up to 120 Watts. When the engine is not running this will, however, discharge the vehicle battery.

For further information refer to Booklet 3.2, "Accessories, modifications and renewal of parts".

### Other electric sockets in the vehicle

According to the model version, other 12 Volt electric sockets can be found in the following positions in the vehicle. They can be used for electrical equipment:

- 2 sockets in the luggage compartment\*, total capacity: max. 180 Watt
- 1 socket behind the the front passenger seat\*, capacity: max. 180 Watt
- 2 sockets in the lower side trims\* right and left next to the seat bench, capacity: max. 180 Watt.

The battery will discharge when electrical equipment is used and the engine is not running.

These sockets will be supplied by the additional battery\* on those vehicles where one is fitted. The additional battery will discharge if electrical equipment is used and the engine is not running.

For further information refer to Booklet 3.2, "Accessories, modifications and renewal of parts".

## Cigarette lighter

Press the lighter button in. The lighter will spring out when the heating element is hot.

Remove the **cigarette lighter** immediately and light your cigarette on the heating element.

### Warning

- **Exercise caution when using the cigarette lighter!**

**Careless or uncontrolled use of the cigarette lighter can cause burns.**

**The cigarette lighter and the socket also work when the ignition is switched off and the key removed.**

**For this reason children should never be left in the vehicle on their own.**

## Ashtray

### Front

Removing:

Pull ashtray fully to rear, press the button on the underside to disengage and take the ashtray out.

Replacing:

Insert ashtray in guides and then push fully in.

### Rear

#### Caravelle and Kombi

Removing:

Open ashtray, press down and take out.

Replacing:

Insert ashtray in from above and then push fully in.

#### Multivan

Removing:

Open ashtray by pressing the cover and remove the insert.

Replacing:

Insert ashtray and then push fully in.

### Warning

**Never use the ashtrays as paper containers. Fire hazard!**

## Dropside (Pick-up)

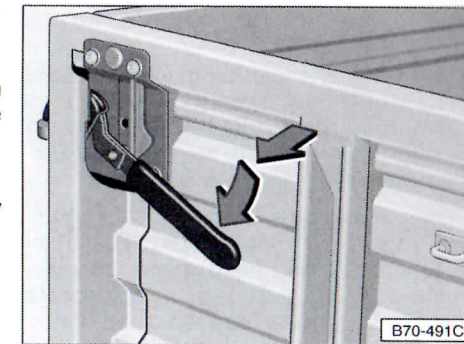

To lower the dropsides pull locking handle outwards until the pin is clear of retaining hole then swing handle down.

**On vehicles with support cables for the tailboard do not place more than 150 kg on tailboard when it is down.**

### Warning

**The tail lights are not visible when the tailboard is lowered. Therefore, if lights are required, other safety measures should be employed, e.g. warning lights.**

Note legal requirements when employing such safety measures.



## Roof rack

When loads are to be carried on the roof, the following should be noted:

- As the rain channels are moulded into the roof for streamlining reasons, the normal type of roof rack cannot be used. To avoid risks we advise that only the cross bars provided by the factory are used.
- These cross bars are the basis for a complete roof load carrying system. For safety reasons when carrying luggage, bicycles, surf boards, skis and boats, the appropriate special adapters are required.

All the components of this system are available from Volkswagen dealers.

- **Any damage which may occur to the vehicle as a result of using other roof load carrying systems or by incorrect fitting will not be covered by the Warranty.**

### Warning

- **Please refer to the accompanying assembly instructions when using the roof load carrier system.**
- **Check all securing points and screws after having driven a short distance, tighten if necessary and then check again after appropriate periods.**

## Roof load

**The permissible roof load (including the carrier system) and the maximum permissible weight of the vehicle must not be exceeded – see Booklet 3.3.**

- Distribute the load evenly. When using carrier systems of a low load threshold, it is not possible to carry loads corresponding to the maximum permissible roof load. **The roof load carrier can only carry loads up to the limit defined in the assembly instructions.**

### Warning

**It should be noted that when transporting heavy items on the vehicle roof, the handling will change due to the displacement of the centre of gravity or as a result of the increased surface space exposed to the wind. Driving style and speed must be altered to suit.**

- Ensure that the opened tailgate does not knock against the roof load.
- Ensure that there is enough space between the sliding roof in the driver's compartment and the roof load. The roof load could otherwise hinder the sliding roof when opening.

## Manual gearbox

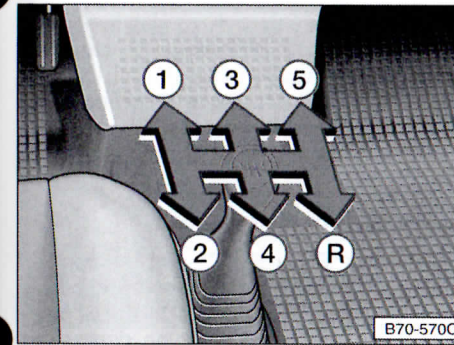

**Gear change diagram**

The diagram applies for 75, 103, 111 and 150-kW engines.

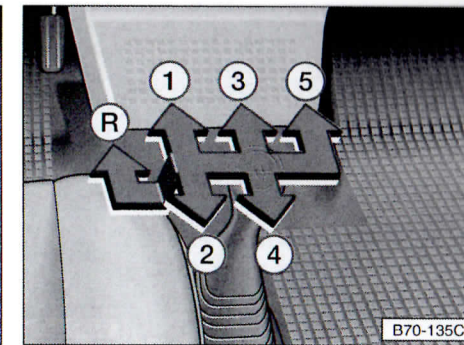

**All other engines**

- Only engage reverse gear when vehicle is stationary. When engine is running, depress clutch fully and wait a few seconds before moving gear lever, to prevent grating noises.

When reverse gear is engaged with ignition on, the reversing lights come on.

### Note

When driving you should not rest your hand on the gear lever. The pressure of your hand is transmitted to the selector forks in the gearbox and can cause premature wear on the forks.



## Automatic gearbox\*

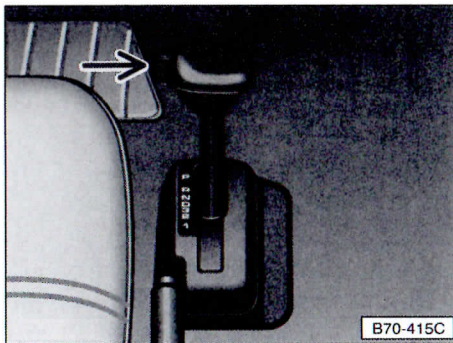

### Driving programmes

The gearbox management is equipped with diverse driving programmes. Depending on the style of driving or on the momentary situation, an **economic**, that is a low-consumption, or a more **“sporty”** programme will be selected.

The programme is selected **automatically** depending on the movement of the accelerator pedal.

If the accelerator pedal is moved **slowly**, or at a **normal** rate, the gearbox will shift into a higher gear earlier, and down into a lower gear later to **reduce fuel consumption**.

A more **“sporty”** programme is selected when the accelerator pedal is moved **rapidly**. The pedal does not have to be depressed to the point of kick-down (see page 118). In this mode, the gearbox will shift up later to make full use of the engine's power reserves.

### Note

Depending on road resistance, for example when trailer towing or on uphill stretches, a programme is automatically selected which provides more power by shifting into a lower gear. This prevents frequent gear changes.

### Selector lever lock

In positions **“P”** and **“N”** with the ignition switched on the selector lever is locked. To move the selector lever out of these positions the brake pedal must be depressed and the selector lever button pushed-in. This prevents a gear being engaged inadvertently and the vehicle unintentionally moving off.

A delay circuit prevents the selector lever from locking when it is moved quickly past the **“N”** position (for instance from **“R”** to **“D”**). This enables for example the vehicle to be **“rocked”** out of a **“bogged down”** position. The shift lock only locks the selector lever if it is left in the **“N”** position for more than about 1 second without the brake pedal being depressed.

At speeds above 5 km/h the selector lever lock is automatically switched-off in position **“N”**.

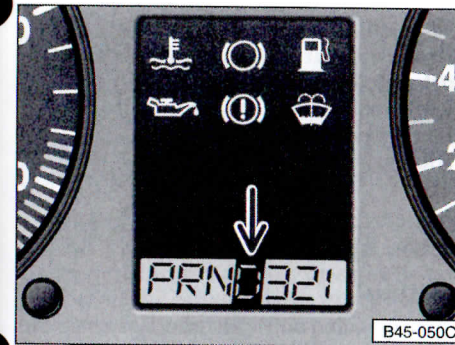

### Selector lever positions

In the combi-instrument there is a display<sup>1)</sup> that shows the currently selected selector lever position.

### Warning

**Never shift selector lever to position “R” or “P” whilst the vehicle is in motion.  
The gears could be damaged – risk of accident!**

### P – Parking lock

The driving wheels are locked mechanically. The parking lock may only be engaged when the vehicle is stationary. Before moving the lever in or out of the **“P”** position the lock button in the selector lever handle must be pressed. Before moving the selector lever out of the **“P”** position with the ignition switched on, the brake pedal must also be depressed.

<sup>1)</sup> Depending upon the model the display can also be fitted in the instrument panel.

### R – Reverse gear

The reverse gear should only be engaged when the vehicle is stationary and with the engine idling. Before engaging the position **“R”** from the positions **“P”** or **“N”** the brake pedal must be depressed and the lock button in the selector lever handle must also be pressed.

The reversing lights come on then the selector lever is in the **“R”** position with the ignition switched on.

### N – Neutral (idling position)

To move the lever out of neutral when stationary or at speeds below 5 km/h and with ignition switched on depress the brake pedal and press the lock button in the selector lever handle.

### D – Normal driving position

The four forward gears are shifted up and down automatically depending upon engine load and road speed.

Under certain driving conditions it is advantageous to engage one of the following described selector lever positions.

### 3 – Position for “hilly” regions

This selector position is recommended in situations where the gearbox alternates frequently between 3rd and 4th gears in the **“D”** position.

The 1st, 2nd and 3rd gears are shifted up and down automatically depending upon engine load, road speed and selected programme (**E** or **S**). The 4th gear is not engaged. This increases the engine braking effect when the accelerator pedal is released.



## 2 – Position for steep hills

This selector lever position is suitable for long climbs and descents.

The 1st and 2nd gears are shifted up and down automatically depending on engine load and road speed. The 3rd and 4th gears are not engaged in order to avoid unnecessary gear changes. This further increases the engine braking effect on deceleration.

## 1 – Position for very steep hills

This selector lever position is recommended for very steep descents.

To engage this gear, the lock button in the selector lever handle must be pressed in. The vehicle only moves in 1st gear. The 2nd, 3rd and 4th gears are not engaged. Maximum possible engine braking effect is now available.

The cruise control \* cannot be used in position "1".

### Note

When changing down manually the selector lever can be moved into the lower gear position, but the gearbox will not change down until it is no longer possible to over-rev the engine.

## Kick-down device

The kick-down device gives maximum acceleration. When the accelerator pedal is pressed right down past the full throttle position, depending on road speed and engine speed, the box changes down into a lower gear. The shift into the next higher gear then takes place as soon as the maximum specified engine speed is reached.

### Warning

**Please note that the driven wheels could go into a spin if the kick-down device is applied on roads with black ice. Risk of skidding!**

## Notes on driving

### Starting<sup>1)</sup>

The engine can only be started when selector lever is at "N" or "P". See also "Starting engine" on page 123.

### Selecting a driving range

**When the vehicle is stationary and the engine is running always depress the foot brake when selecting a gear.**

**When the vehicle is stationary do not depress the accelerator when selecting a gear.**

**If the lever is moved accidentally into "N" when driving, release accelerator and let the engine speed drop to idling before selecting a forward gear again.**

### Warning

**Please take notice of the warning notes on the next pages.**

<sup>1)</sup> If the button in the selector lever is pressed and held before the ignition is switched on, the ignition key will not be able to be turned.

### Warning

**When the engine is running the foot brake must be applied for all driving ranges as the transmission will not be completely interrupted at idling speed – the vehicle "creeps".**

**When the vehicle is stationary and a gear is engaged, the throttle must not be opened inadvertently on any account (for instance by hand from the engine compartment). Otherwise the vehicle will move immediately – even if the handbrake has been fully applied.**

**Before working on the vehicle with the engine running, apply the handbrake and put the selector lever in "P".**

## Moving off

Select driving range (**R, D, 3, 2, 1**). **Wait until the gearbox has shifted and the power flow is made to the driving wheels** (light selection jerk perceptible). **Then one can accelerate.**

## Stopping

When the vehicle is stopped for a short period, at traffic lights for example, it is not necessary to move the selector lever to position "N". It is only necessary to apply the foot brakes. The engine should however only be running at idling speed.

On some engine models, the gearbox will shift automatically to idling (N) if the position R, D, 3 or 2 has been selected and the vehicle is on a level surface.

Noise levels and fuel consumption are reduced in this way. The vehicle may move off more slowly than normal as the power line to the drive wheels is then slightly delayed.



**Parking**

**Warning**

**To prevent the vehicle rolling away inadvertently, you should always apply the handbrake firmly when the vehicle has come to a complete stop. Also place the gear selector lever in position "P".**

On a gradient the handbrake should be applied firmly first and then the parking lock engaged. This will ensure that the locking mechanism is not too heavily loaded and makes the lock easier to disengage.

**Tow starting**

On vehicles with automatic gearbox the engine cannot be started by towing or pushing the vehicle – see Booklet 3.2.

When the battery is flat, the engine can be started from the battery of another vehicle by using jumper cables. See "Emergency starting", Booklet 3.2.

**Towing**

If the vehicle has to be towed at any time, you must read the instructions in the section "Towing/tow starting" in Booklet 3.2.

**Handbrake**

To apply the handbrake pull lever up firmly. On hills the 1st gear or with automatic gearbox the parking lock should also be engaged. The handbrake should always be applied so firmly that it is not possible to drive inadvertently with the handbrake on.

When the handbrake is applied with the ignition on, the brake system warning lamp or the handbrake warning lamp will come on, depending on the model version.

To release handbrake, pull lever up slightly, press locking knob in and push lever right down.

**Warning**

**● To prevent the vehicle rolling away inadvertently, you should always apply the handbrake firmly after the vehicle has come to a complete stop.**

**You should also put the car into gear (manual gearbox) or the gear selector lever in position P (automatic gearbox).**

**● Please note that the handbrake must be released completely after application. If the handbrake is only partly released it could lead to overheating of the brakes and thus negatively affect the function of the brake system. This could also lead to premature rear brake lining wear.**

**Ignition lock**

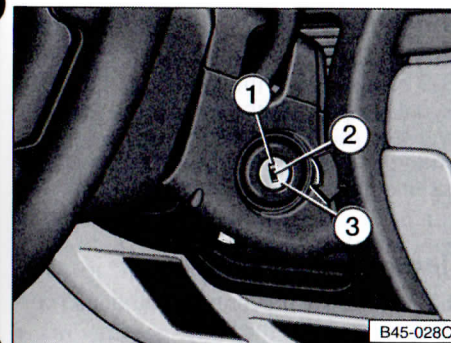

**Petrol engines**

- 1 - Ignition off, engine off, steering wheel can be locked
- 2 - Ignition on
- 3 - Starting engine

**Diesel engines**

- 1 - Fuel supply cut off, engine off, steering wheel can be locked
  - 2 - Glow and drive position
- To prevent draining the battery unnecessarily, large current consumers should not be switched on together with the glow plugs.
- 3 - Starting engine

**Warning**

**Do not withdraw key from lock until vehicle is stationary! The steering lock could be unintentionally engaged.**

**● If the vehicle is left – even if only temporarily – always remove the ignition key. This is particularly important if children are to remain in the vehicle. They could otherwise start the engine or operate the electric equipment e.g. electric windows. Risk of accident!**

**● To prevent the vehicle rolling away inadvertently, you should always apply the handbrake firmly when the vehicle has come to a complete stop.**



**For all vehicles:****Position 1:**

To **lock the steering wheel** withdraw key and turn wheel until you hear the locking pin engage.

We recommend that the steering wheel always be locked when you leave the vehicle. The possibility of your vehicle being stolen is drastically reduced in this way.

**Note**

If lights or turn signals are not switched off, a buzzer\* will sound, after the ignition key has been removed, when the driver's door is open.

**Position 2:**

If the key is difficult to turn in the lock or cannot be turned to this position at all, the steering wheel must be rocked to and fro slightly to release the locking pin.

**Position 3:**

In this position the headlights and other heavy current consumers are switched off. Before the starter can be operated again the key must be turned back to position **1**. The non-repeat mechanism in the ignition lock prevents the starter from being operated when engine is running, as this could damage the starter.

**Ignition key lock\***

On vehicles with an automatic gearbox\* after switching off the ignition the ignition key can only be withdrawn if the selector lever is in the "P" position. When the ignition key has been withdrawn the selector lever is locked in this position.

**Electronic immobilizer**

The immobilizer prevents unauthorized persons using your vehicle.

A micro-chip is located in the head of the key which automatically deactivates the immobilizer when the key is inserted in the ignition lock.

The system is automatically activated when the ignition is switched off.

**The engine can thus only be started with a correctly coded Genuine Volkswagen key.**

**Trouble free operation of your vehicle can only be guaranteed when using genuine keys.**

**Starting the engine****General notes****Warning**

**When running the engine in confined spaces there is a danger of poisoning.**

- Before starting, move gear lever to neutral (with automatic gearbox, selector lever in "P" or "N" position) and apply handbrake firmly.

- On vehicles with a manual gearbox depress the clutch pedal when operating starter so that starter only has to turn engine.

- As soon as engine starts, release the ignition key so that starter can disengage.

- After starting a cold engine it may sound noisy for a moment or two because the oil pressure has to build up in the hydraulic tappets first. This is normal and no cause for alarm.

**✿ Do not warm engine up by running it with vehicle stationary. Drive off straight away.**

- Do not overrev or use full throttle until the engine has reached the normal operating temperature.

- **On vehicles with a catalytic converter the engine must not be started by towing the vehicle in excess of 50 m. Otherwise unburnt fuel can pass into the converter and lead to damage.**

- **Before trying to start the engine by towing, an attempt should be made, if possible, to use the battery of another vehicle – see Booklet 3.2, "Emergency starting".**

**Petrol engines**

These engines are equipped with a petrol injection system that automatically supplies the correct fuel/air mixture at all ambient temperatures.

When engine **is cold or at operating temperature** do **not** accelerate before or during the starting procedure.

If the engine does not start at once, stop using the starter after 10 secs. wait about half a minute and then try again.

If the engine still does not start, the electric fuel pump fuse may have blown – see Booklet 3.2, "Fuses".

When the engine **is very hot** it may be necessary to accelerate slightly after the engine has started.



## Diesel engines

### Glow plug system

After switching to the driving position (ignition on), the required glow plug warm-up time is indicated by a lamp which is controlled by the coolant temperature.

### Cold starting aid

To facilitate starting **50 and 55 kW engines** from cold, there is a cold starting device (cold starting aid) in the injection pump. The cold starting device is actuated when the knob on the left of the steering column is pulled out **fully**.

### 50 and 55 kW engines

#### Starting a cold engine

- At ambient temperatures of between **+18°C** and **-15°C**, pull the cold start knob out **fully** before operating the starter.

At lower temperatures, the knob should not be pulled out **until engine is firing regularly** – the engine will then start more readily.

- Turn the key in the ignition lock to position 2 – see page 121 – the glow plug warning lamp comes on. It goes out when the ignition temperature is reached – see page 21.

**While the glow plugs are working do not switch on any heavy current consumers because this would place an unnecessary load on the battery.**

- When the warning lamp goes out, start the engine immediately.

Do not depress the accelerator while starting.

If the engine only fires irregularly, continue to operate the starter a few seconds longer (30 seconds at maximum) until the engine runs under its own power.

If the engine does not start, repeat preglow and try starting it again as described. If the engine still does not start the fuse for the Diesel glow plugs may have blown – see Booklet 3.2, "Fuses".

- Push the cold start aid knob in fully as soon as the engine has reached its normal operating temperature.

#### Starting a warm engine

The glow plug lamp does not come on – the engine can be started straight away. Do not pull the cold start aid knob and do not press the accelerator pedal.

### 65, 75 and 111 kW engine

#### Starting a cold engine

- Turn the key in the ignition lock to position 2 – the glow plug warning lamp comes on. It goes out when the ignition temperature is reached.

**While the glow plugs are working do not switch on any heavy current consumers because this would place an unnecessary load on the battery.**

- When the warning lamp goes out, start the engine immediately.

Do not depress the accelerator while starting.

If the engine only fires irregularly, continue to operate the starter a few seconds longer (30 seconds at maximum) until the engine runs under its own power.

If the engine does not start, repeat preglow and try starting it again as described. If the engine still does not start the fuse for the Diesel glow plugs may have blown – see Booklet 3.2, "Fuses".

#### Starting a warm engine

The glow plug lamp does not come on – the engine can be started straight away.

#### Starting after tank has been run empty

If the tank on vehicles with a diesel engine was empty, starting after filling with diesel fuel can take longer than normal – up to one minute. This is because the fuel system must first be freed of air before starting.

## Stopping engine

**When engine has been running fast for a long time, let it idle for about 2 minutes before switching off to prevent a build up of heat.**

### Warning

**After the engine has been stopped the fan can continue running for a while (up to about 10 minutes) with the ignition switched off. It can also start to run again suddenly after a short time if**

- the coolant temperature increases due to heat build-up
- when engine is hot and the engine compartment is heated additionally by strong sunlight.

**Special care must therefore be taken when working in the engine compartment.**



## Cruise control system\*

To relieve the foot on the accelerator pedal this system can hold any speed above about 45 km/h (25 mph) constant, so far as this is permitted by engine output.

The cruise control system cannot keep a constant speed when driving downhill. The speed will increase as a result of the vehicle. The brakes should be applied.

### Warning

**The cruise control system should not be used in dense traffic and poor road conditions (slippery surfaces, aquaplaning, gravel).**

**When system is switched on do not move into neutral without depressing the clutch pedal, otherwise the engine will race and can, under certain circumstances, become damaged.**

On vehicles with automatic gearbox, the Cruise Control System is only active when the gear selector is position **D**, **3** or **2**. If any other position (**P**, **N**, **R** or **1**) is selected while driving, the last speed to be stored is deleted and the system switched off.

### Switching on

The system is operated with the sliding switch **A** and the press button **B** on the turn signal lever.

The system is **switched on** by moving switch **A** to ON.

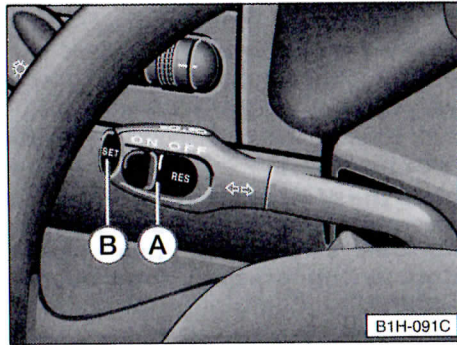

### Storing speed

When the speed to be maintained has been reached the press button **B** (SET) must be pressed briefly. The foot can then be taken off the accelerator pedal.

The speed can also be increased in the normal way with the accelerator pedal. When the pedal is then released the previously programmed speed is resumed.

This is, however, not the case when the stored speed is exceeded by more than 10 km/h for a period of more than 5 minutes. The speed must then be stored again.

### Warning

**The programmed speed must only be resumed when it is not too high for the existing traffic conditions.**

## Altering stored speed

### Reducing / Setting

The stored speed can be reduced by pressing button **B**.

By pressing button **B** briefly, the stored speed is reduced by a preset amount. If you press and hold the button, the speed will decrease through automatic deceleration. The speed reached when releasing the button will be saved.

If the button is released at a speed of less than approx. 45 km/h, the memory is deleted. The speed must then, if necessary, be reset using button **B** after the vehicle has accelerated to a speed higher than approx. 45 km/h.

### Accelerating / Storing

The stored speed can be **increased** without depressing the accelerator by moving the slide control **A** to the left.

By briefly pressing the slide control, the speed is increased by a preset amount. If the switch is moved to the left and held, the speed is increased through automatic acceleration. The speed reached when the switch is released is then saved.

## Switching system off temporarily

### Vehicles with manual gearbox:

The system is **temporarily switched off** when brake or clutch pedals are used or when speed is considerably below programmed speed i.e. when driving up a steep gradient in too high a gear.

The speed stored at this time **will remain in the memory**.

To **resume** the previously stored speed push switch **A** fully to the left after the brake or clutch pedals are released.

### Warning

**The programmed speed must only be resumed when it is not too high for the existing traffic conditions.**



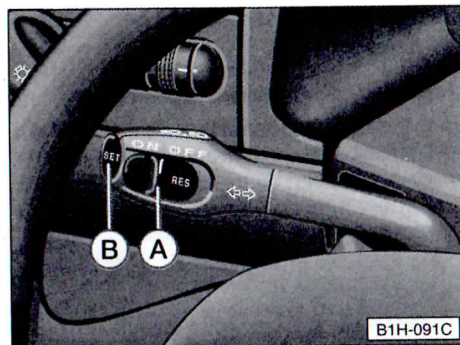

**Storing speed**

If no speed was saved before the system was temporarily switched off or if the stored speed was deleted, a new speed can be set using switch **A** as follows:

- Move switch **A** fully to the left and hold until the desired speed has been reached. The speed is stored after the switch has been released.

or

- Press button **B** briefly. The current speed is stored.

**Vehicles with automatic gearbox:**

The system is **temporarily switched off** when brake or clutch pedals are used or when the switch **A** is moved to OFF (not engaged).

The speed stored at this time **will remain in the memory**.

To **resume** the previously stored speed push switch **A** fully to the left when brake or clutch pedals are released.

**Warning**

**The programmed speed must only be resumed when it is not too high for the existing traffic conditions.**

Furthermore, the system will be **switched off temporarily** if the selector lever is moved to positions **N** or **1**.

The speed stored in the memory at this time **will be deleted**.

**Switching system off completely**

**Vehicles with manual gearbox:**

The system is **completely switched off** by moving the switch **A** fully to the right (OFF) or – when vehicle is stationary – by switching the ignition off.

**Vehicles with automatic gearbox:**

The system is **completely switched off** by moving the selector lever:

- to positions **P, N, R** or **1**

or

by switching off the ignition **when the vehicle is stationary**.

**Electronic Stability Programme\***

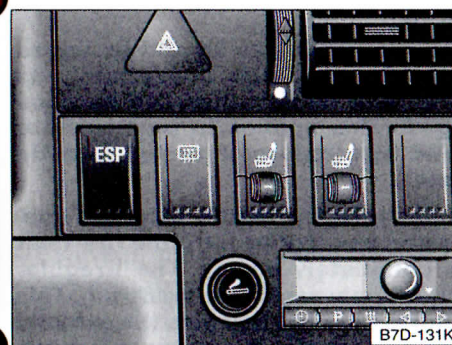

**Switching off the ESP / TCS**

The ESP/TCS should always be switched on under normal circumstances.

Press the button (see illustration) to turn off the system.

When the system is switched off, the ESP warning lamp will light up – see page 22.

Only in certain cases, when wheel spin is required, is it advantageous to switch off the system.

For example

- when driving with snow chains
- when driving in deep snow or on a loose surface
- when freeing the vehicle if it is stuck.

The system should then be switched on again by pressing the button. The system will switch on automatically when the engine is turned on.



### Filling the tank

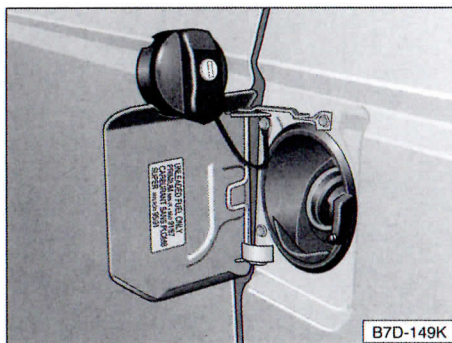

The filler neck is on the left-hand side of the vehicle.

You can reach the lockable\* cap after having opened the tank flap (see illustration).

The tank flap can be locked and unlocked with the ignition key.

When the tank cap has been taken off, it can be hooked over the tank flap – see illustration.

The tank holds about 80 litres.

**✿ As soon as the correctly operated automatic nozzle switches off for the first time, the tank is full. Do not try then to put more fuel in because the expansion space in tank will be filled – the fuel can then overflow when it becomes warm.**

After filling tank, screw cap on tightly and lock it.

Please do not forget to close the tank flap again.

#### Note

**Any fuel spillages should be wiped off the paint finish immediately, as the paint could otherwise be damaged. This applies in particular to RME fuel (rapeseed methyl ester/diester).**

**● On vehicles with a catalytic converter, never drive until the fuel tank is completely empty. The irregular fuel supply can cause misfiring. This allows unburnt fuel into the exhaust system, which can cause overheating and damage to the catalyst.**

#### Warning

**Any statutory regulations must be observed when carrying a reserve canister of fuel. For safety reasons it is recommended that a reserve canister not be carried. In the event of an accident, the canister could be damaged and fuel spillage could occur.**

## ALPHABETICAL INDEX

### A

Additional seat adjustments	
– Driver's seat	75
– Front passenger's seat	75
Air extraction	63
Airbag	
– Airbag warning lamp	22
Alternator warning lamp	18
Anti-dazzle interior mirror	71
Anti-locking Brake System	
– Warning lamp	23
Arm rests	76
Ashtray	113
Auto-check system	25
– Function check	25
Automatic gearbox	116
– Reversing lights	117

### B

Bed panel	
– Raising	57
– Removing and installing	57
Belt retainer	
– Rear seat bench	100
– Seat bench	99
– Single seat	95
Bonnet	58
Brake warning lamp	18
Brake wear monitor	22
Buzzer	61, 122

### C

Canvas window	53
CD changer location	83
Central locking	40
Centre seat bench	
– Installing	99
– Removing	99
Check system	25
Child-proof lock	
– Sliding door	34
– Tailgate	39
– Wing door	37
Cigarette lighter	112
Cockpit	3
Cold starting aid	124
Coolant temperature gauge	8
Coolant level	19
Cruise control system	126
Curtains	73



## ALPHABETICAL INDEX

### D

Dash panel ..... 3  
 Dash panel lighting ..... 62  
 Daylight driving lights ..... 61  
 Diesel engines  
   – Empty tank ..... 125  
   – Starting ..... 124  
 Dip lever ..... 64  
 Door locks ..... 34  
 Doors ..... 34  
 Drink can holder ..... 104  
 Driver's seat ..... 74  
   – Additional adjustments ..... 75  
 Dropside ..... 113  
 Drying roof ..... 55

### E

Electric socket ..... 112  
 Electric windows ..... 45  
 Electronic immobilizer ..... 33, 122  
 Electronic Stability Programme ..... 22, 129  
 Emergency key ..... 32

Engine  
   – Oil pressure ..... 20  
   – Oil level ..... 20  
   – Safety notes ..... 60  
   – Starting/stopping ..... 123  
 Engine management system ..... 21  
 Enlarging luggage space ..... 100  
   – Multivan ..... 86  
 Entry area light ..... 66



### Environment

  – *Filling the tank* ..... 130  
 Exhaust emission warning lamp .. 21  
 Exterior mirror ..... 71

### F

Filling the tank ..... 130  
 Foglights ..... 61  
 Folding exterior mirrors in ..... 72  
 Folding exterior mirrors out ..... 72  
 Folding seat ..... 96  
 Folding table ..... 110  
 Foot mats ..... 78  
 Front passenger's seat  
   – Additional seat adjustments .. 75  
 Front seats ..... 74  
 Fuel gauge ..... 9  
 Fuel reserve ..... 22

## ALPHABETICAL INDEX

### G

Gear change diagram ..... 115  
 Gear stick ..... 115  
 Glove box ..... 82  
 Glove box light ..... 66  
 Glow plug warning lamp ..... 21  
 Glow plugs ..... 124

### H

Hand-held telephone ..... 30  
 Handbrake ..... 19, 120  
 Hazard warning lights ..... 62  
 Head restraints ..... 77  
 Headlight flasher ..... 64  
 Headlight range control ..... 62  
 Headlight washer system ..... 68  
 Heated front seats ..... 78  
 Heated mirrors ..... 72  
 Heated rear window ..... 73  
 Holder for coins for parking metres 82  
 Horn ..... 3

### I

Ignition lock ..... 121  
 Immobilizer ..... 33, 122  
 Indicators ..... 21, 64  
 Installing seat  
   – Folding seat in Multivan ..... 92  
   – Single seat with refrigerator .. 97  
 Instrument lighting ..... 62  
 Instruments ..... 6  
 Interior lights ..... 65  
 Interior mirror ..... 71

### K

Key tag ..... 32  
 Key with built-in light ..... 33  
 Keys ..... 32  
   – Security locking ..... 33  
 Kick-down ..... 118



## ALPHABETICAL INDEX

### R

Radio wave key without function . . . . .	43	Removing seat bench	
Radio wave remote control . . . . .	42	– Centre seat bench . . . . .	99
Radio wave remote control key		– Multivan . . . . .	87
– Synchronisation . . . . .	43	– Rear seat bench . . . . .	101
Reading light . . . . .	65	Replacement keys . . . . .	32
Rear fog light . . . . .	21	Rev counter . . . . .	7
Rear seat bench . . . . .	100	Reverse gear . . . . .	117
– Double cab . . . . .	103	Reversing lights . . . . .	115
– Driving position . . . . .	100	– Automatic gearbox . . . . .	117
– Fitting . . . . .	102	Roof	
– Removing . . . . .	101	– Airing . . . . .	55
– Tipping . . . . .	101	– Closing . . . . .	54
Rear view mirror . . . . .	71	– Lifting . . . . .	52
Rear window		Roof bed . . . . .	56
– Heating . . . . .	73	Roof light . . . . .	63
Rear window wash/wipe . . . . .	68	Roof load . . . . .	114
Refrigerator . . . . .	106	Roof load carrying system . . . . .	114
– Removing . . . . .	108	Roof rack . . . . .	114
– Tips for use . . . . .	109	Roof vent . . . . .	63
Remote control . . . . .	42	Rotating seat . . . . .	97
Removing seat		– Securing child seat . . . . .	90
– Folding seat in centre seat row . . . . .	96	Rotating seats . . . . .	89
– Folding seat in Multivan . . . . .	92		
– Rotating seat in Multivan . . . . .	91		
– Single seat in centre seat row . . . . .	95		
– Single seat with refrigerator . . . . .	97		

## ALPHABETICAL INDEX

### S

Safety notes . . . . .	60	Securing child seat . . . . .	90, 97
Seat belt warning lamp . . . . .	18	Security locking . . . . .	33
Seat bench		Selector lever . . . . .	117
– Installing . . . . .	87	Service Interval Display . . . . .	14
– Sleeping surface . . . . .	86	Side lights . . . . .	61
Seat cushion		Single folding seats . . . . .	92
– Installing . . . . .	103	Single seat	
– Removing . . . . .	103	– Installing . . . . .	95
Seat heating . . . . .	78	– Removing . . . . .	95
Seat position		Sleeping surface . . . . .	86
– Driver's seat . . . . .	74	Sliding door . . . . .	34
– Front passenger seat . . . . .	74	Sliding roof . . . . .	48
Seat runners . . . . .	85	Sliding window . . . . .	44
Seat stop . . . . .	75	Sliding/tilting roof . . . . .	50
Seats . . . . .	74	Socket . . . . .	112
– Adjusting . . . . .	74	Speedometer . . . . .	9
– Folding . . . . .	92	Starting the engine . . . . .	123
Seats in passenger compartment . . . . .	84	– With an empty tank . . . . .	125
– Seat/sleeping surface . . . . .	86	Steering/starter lock . . . . .	121
		Stopping engine . . . . .	125
		Stowage box . . . . .	82
		Sun screen . . . . .	48
		Sun visors . . . . .	70
		Sunroof . . . . .	50
		Switches . . . . .	61



## ALPHABETICAL INDEX

### T

Tachograph .....	16
Tailgate .....	39
– Luggage carrier .....	39
Tank cap .....	130
Telephone mounting .....	30
Thermal box .....	106
– Installing .....	109
Trailer turn signals .....	21
Transistor light .....	66
Trip meter .....	14
Turn signals .....	21, 64

### U

Unlatching door .....	34
Unlocking door .....	40

### V

Variable Service Interval Display ..	15
Vehicle Navigation system .....	24
Ventilation .....	63

### W

Warning lamps .....	17
– Airbag system .....	22
– Alternator .....	18
– Anti-locking brake system ...	23
– Brake wear monitor .....	22
– Coolant temperature .....	19
– Electronic Stability Programme	22
– Engine management system .	21
– Exhaust emission .....	21
– Fuel reserve .....	22
– Handbrake .....	19
– Main beam .....	21
– Rear fog light .....	21
– Seat belt warning lamp .....	18
– Trailer turn signals .....	21
– Turn signals .....	21
Waste container .....	83
Window in front canvas .....	53
Windows .....	45
Windscreen wiper .....	67
Wing doors .....	36
– Open .....	36
Wiper blades .....	69
Wiper/washer system .....	67

VOLKSWAGEN AG is working continuously on the development of all types and models. Please appreciate that we must reserve the right to change our models in shape, equipment and technology at any time. No legal commitment is therefore implied by the details, illustrations and descriptions in this manual.

The texts, illustrations and norms in this manual are based on the information available at the time of going to print.

Printing, reproducing or translation, in whole or in part, is not permitted without written permission from VOLKSWAGEN AG.

All rights are reserved expressly by VOLKSWAGEN AG. Subject to modification without notice.

Produced in Germany

© 2000 VOLKSWAGEN AG

Print status: October 2000

 This paper was manufactured from pulp bleached without using chlorine.



**T4 - Controls and Equipment**  
**Part1**  
**englisch 12.2000**  
**212.551.TB1.20**