

All Carbine ELECTRIC 12V  
ARE FUSED BY BATTERY BOX

T4 VILLA ER/HT

RICHARD HOLDSWORTH CONVERSIONS LTD





**WARNING** - before every journey the driver must carry out a number of checks for the safety of the vehicle and its occupants. These include those contained in the Owner's Manual produced by the vehicle manufacturer; AND the driver must check the conversion including:

- \* Turn off regulator on gas cylinder and check that cylinder(s) are stored securely. **NEVER** operate any gas appliance - including refrigerator on gas - when in motion or in a petrol station/when filling with petrol.
- \* Remove all but the lightest items from cupboards above waist level.
- \* Stow securely all heavier items within other cupboards and **MAKE SURE** they will not become loose while the vehicle is in motion.
- \* Stow toilet and other pieces of equipment securely.
- \* Stow table, table leg and other motor caravan fittings securely.
- \* Close all cupboard doors, lower furniture unit lids and locate all sliding seats (if fitted).
- \* Check that the elevating roof (if fitted) is lowered and secured properly.
- \* Carry only lighter items in roof rack (if fitted) and make sure any such items are secure.
- \* Apply rear seat restraints as these can lead to a more comfortable journey and help reduce the risk of injury in the event of a slow speed collision.

**IN NO CIRCUMSTANCES SHOULD VEHICLE OCCUPANTS MOVE AROUND THE VEHICLE WHILE IT IS IN MOTION.**

**THE VOLKSWAGEN VILLA**

Welcome to your Richard Holdsworth VOLKSWAGEN VILLA motor caravan which we hope will give you great enjoyment for many years to come. The following notes are to help you become familiar with the use of the excellent motor caravan conversion; they should be read in conjunction with the Volkswagen Instruction Manual provided by the vehicle manufacturers, which provides information on the vehicle itself.

Naturally, you will want both your vehicle and your motor caravan conversion to give the very best service, and we would underline the need to read these instructions with care, and to implement their recommendations wherever necessary. The same applies to the instructions provided by the manufacturers of standard and optional items such as the cooker, refrigerator and caravan heater.

Failure to do so in the case of gas appliances can - for example - result in the occupants being put at some risk, while failure to follow recommendations on other items can result in their premature failure for which the manufacturer may not wish to be held responsible.

Richard Holdsworth Conversions Ltd  
Headley Road East  
Woodley  
Reading  
Berkshire  
RG5 4NE

September 1991

## CONTENTS

PAGE	
4	The Driving Compartment
5	Seating/Dining/Sleeping
6	Toilet Compartment & Storage & 4 Berth
7	Exterior Storage - Table
8	Kitchen unit - Water & Gas Supply
12	Gas & Water System Diagrams
13	Electrical Systems & Fittings
16	Wiring Diagram - 12 Volt
17	Wiring Diagram - 240 Volt
18	Wiring Diagram - Aux. Battery
19	Refrigerator
21	Elevating Roof
23	Care & Maintenance of your Motorcaravan
25	Optional Equipment - Propex Heater
26	Removal of Flyscreen
27	Wiring Diagram - Propex Heater
28	Technical Data
29	Control Panel Instructions

## THE DRIVING COMPARTMENT

The Volkswagen Villa motor caravan does not affect the cab of the Volkswagen except that the VW passenger seat is made to swivel, and that both seats are re-trimmed to match the remainder of the seat fabric used in the motor caravan. The carpet used in the rear of the motor caravan is also extended through into the VW cab for coziness and warmth.

Please note: the driver's cab seat can also be fitted with a swivel function at the time of building the conversion, and a cab table installed between the two cab seats and this makes a welcome additional dinette within the Villa for a small additional outlay. The swivel facility for the driver's seat and the cab table can be provided by most good dealers at a later date, (or at the Richard Holdsworth factory) but there is often a waiting list for the work to be done, and there may be an additional cost over the motor caravan optional extras price list.

You may also wish to note that the driver's seat does not swivel to the same extent as the passenger seat simply because of the positioning of the steering wheel. In addition, the vehicle needs to be put into gear and the hand brake released to allow the seat to face inwards.

The passenger seat can best be rotated by sitting on the driver's seat or by standing outside the vehicle with the passenger door open. First move the seat forwards by means of the usual VW seat adjustment. Push the floor mounted safety belt stem down out of the way, and open the passenger door to allow the seat to swing. Find the locking lever which is at the rear of the seat. Hold down the lever and rotate the seat to the required position, making sure that the seat belt is not fouled as the seat is rotated.

The locking lever operates when the seat is in the full forward or full rearward positions. After rotating the seat, adjust the seat fore and aft as required.



**WARNING:** Do not drive or use your motor caravan without first reading and implementing the instructions at the beginning of this manual. The instructions are for the SAFETY of YOU, YOUR PASSENGERS AND OTHER ROAD USERS!

### SEATING/DINING/SLEEPING arrangements

The Villa layout is conventional, and is similar to several other Volkswagen motor caravans on the market today. The kitchen unit is situated down the off-side of the vehicle and contains the cooker and sink, while the main seat is situated towards the rear and runs two-thirds of the way across the vehicle. However, there are a number of nice little touches which will make the Villa a more versatile and easy to use motor caravan once out on the camp site.

For a start, you will find the patented Richard Holdsworth rear bench seat/bed device which is the easiest to use, both for making up a bed and for returning the bed to a bench seat afterwards. To make the bed, purely lift the front of the seat so that it clears the 'stop' built into the seat, then simply pull the seat forwards to make the bed. The back-rest and cushions will drop into place and the only other operation you may need to do is press the cushions into place to make a smooth bed.

Should you need to gain access to the storage box beneath the bed - as one will always want to do from time-to-time, simply lift the front edge of the seat (now formed as a bed) and the storage is immediately accessible, as it is when formed as a seat.

To return the bed to a bench seat, pull on the strap in the centre of the seat back-rest while at the same time pushing the seat backwards. The seat will automatically be formed, but make sure that the seat base rides up over the 2nd 'stop' so that it is firmly held in place when the vehicle is in motion. When the vehicle is stationary, the seat may be fixed on the 1st stop, to obtain a semi-reclining position.

For night-time privacy, full curtaining is provided in your Villa. In particular, you will note that the curtains overlap at the centre and there are velcro tabs, or poppers on most curtains to hold them in place. In addition, the cab curtains are provided with small elasticated loops which can be hooked over the window winder handle to keep these curtains firmly against the side of the van.

There are ample lights provided when darkness falls. On the front face of the top cupboard there is a spotlight which can be directed for reading either when in bed or when sitting on the rear bench seat. There are also 8 watt fluorescent lights on either side of the van and also a small courtesy filament light immediately to the rear of the vehicle sliding door which operates when the sliding door is opened and a similar light in the vehicle cab which operates from the cab doors. These two lights are installed by the vehicle manufacturer and your local VW dealer will be able to provide replacement bulbs while replacement fluorescent tubes can be obtained at most good motor caravan or caravan accessory shops.

### TOILET COMPARTMENT

There is a special toilet compartment on your Villa in the very front of the long kitchen unit. The compartment contains a Fiamma 500 toilet which is supplied with your Villa from new. The toilet uses a propriety chemical such as Aqua-chem, which is obtained at most caravan accessory shops. Full instructions for the operation and maintenance of the toilet are contained within the vehicle.

### STORAGE

There is ample storage in your Villa motor caravan firstly in the sliding box beneath the rear seat, in the top locker above and to the rear of the seat and in the area beneath the bed. However, please note - the top locker is for LIGHT ITEMS only and the reason for this is the fact that heavier items (tins of food etc. etc.) can fly out of this locker if the vehicle is braked heavily and these objects can cause injury to the motor caravan occupants.

Note also that the storage space beneath the rear bed cushion is accessed from outside the vehicle when the rear door or tailgate is opened.

Additional storage is found in the long storage unit, the wardrobe and (in the Villa high top) the rear storage area beneath the fibreglass high top. However, as with the top cupboard, only lighter items should be stored in the area beneath the fibreglass high top - items such as sleeping bags, pillows etc are ideal for this area.

### FOUR BERTH VILLA

The Villa elevating roof and Villa high top models can be used as four berth motor caravans with the purchase of an additional kit of parts. In both cases, the sleeping accommodation is purely for youngsters with the length of each roof bed being no more than five feet.

In the case of the Villa high top, the parts supplied to create a four berth include a sliding roof bed panel and two cushions. If your Villa has been supplied as a two berth, you will find a low partition fitted to the front of the roof storage area - this should remain in situ when the bed is not being used as it helps prevent the sliding panel, cushions and other objects from falling from the storage area. Before making up the roof bed, remove the partition and store it somewhere within the vehicle ready for its replacement next morning.

### EXTERIOR STORAGE

The Villa high top has a roof top storage area and a rear ladder to reach this storage. Care should be exercised in gaining access to the storage particularly in wet or frosty weather, the rungs to the ladder can be slippery and cause a fall. Please note that the roof top storage area is for light items only - such as awning tents - and there is a maximum weight limit of approximately 15 kilos or 30lbs., and in no circumstances should operators stand or kneel on the floor of the storage area, damage thus caused will only be repaired by the converter at the owner's expense.

Villa elevating roof: There is a small storage area on the top of the elevating roof and this can be used for extremely light items and there is a weight limit for goods carried in this area of 10 kilos or 20lbs. The elevating roof structure and/or its lifting mechanism can be damaged if this weight limit is exceeded and the manufacturer will not be held responsible for such damage. Likewise, under no circumstances should operators stand, kneel or sit on the roof top as this will also cause damage which will not be repaired under warranty.

**NOTE:** All luggage must be removed from the roof before the roof is elevated.

### TABLE

The main table is located on a single pillar so that it will swivel through 360°. Take the table pillar leg from its position in the wardrobe, and press it firmly into the floor recess. Take the table and mount it on top of the table leg.

**NOTE:** Single pillar tables cannot be as firm or steady as the conventional four legged table, but maximum firmness can be achieved each time the table is erected by pressing down firmly on the table so that the leg is forced hard into the floor and table cones.

The main table is designed to be used in conjunction with the rear bench seat and is too far away from the swivelling passenger seat to be used in comfort. Additional meal settings can be achieved in the Villa by having the cab driver's seat swivel and having the optional cab table fitted. This would be fitted on a swinging pillar located behind the front passenger seat.



### KITCHEN UNIT - WATER & GAS SUPPLY

The fresh water tank is located under the vehicle and holds approximately 54 litres. Some water remains in the tank below the level of the pump draw off. The tank is filled by means of the external fresh water filler cap on the off-side of the vehicle.

The exterior filler is provided with a locking cap which is filled by means of turning the cap in an anti-clockwise direction, and using either a water container and funnel or direct from a tap with the aid of a pipe, (many experienced motor caravanners carry with them a short length of piping specifically for this task).

**PLEASE NOTE:** When operating the lock on the water filler cap, make sure that the key is fully turned before attempting to remove the cap. To avoid damaging the lock, never attempt to remove the cap with the key. Hold the cap firmly, press in and turn anti-clockwise.

The water tank is fitted with breather holes which may allow water to leak onto the ground - this is especially so when the tank is filled to the brim or if the vehicle is parked on an angle. It does NOT necessarily mean that the tank is leaking!

The locking cap is provided with two numbered keys. We would suggest you keep one in a safe place while the other is kept for regular use.

**NOTE:** Always retain a reference of your key number so that replacements can be provided if they both become lost.

**WARNING:** Neither ourselves as manufacturers nor your dealers retain the key numbers, and we are unable to provide replacement keys without the appropriate number.

The water tank can be drained by means of a plastic tap situated on the nearside of the tank. The tap turns through 180°. A small white plastic filter unit is fitted in the supply pipe from the water tank and can be removed from underneath the vehicle by unscrewing the jubilee clips joining it to the water pipe.

The water tank itself should be drained periodically and flushed through. Before winter, it is essential to drain the tank and - in fact - the whole water system to prevent it from freezing up. Failure to do so can result in damage to the tank, pipes and water pump for which the manufacturer will not wish to be held responsible.

Water left in the fresh water tank for extended periods may also become unsuitable for drinking or for washing up purposes, and for this reason also the tank must be drained and flushed through if the motor caravan is not to be used for even short periods.

Sometimes, water from plastic tanks can taste a little strange - particularly early on in the life of the motor caravan. Should the water become tainted, the water tank and water system can be treated with a proprietary product called Milton (available from chemists). Puritabs (also available from chemists) will make water safe but many motor caravanners these days prefer to fit in-line filters. There are several good filters on the market, one of the most popular being the Safari available from good motor caravan accessory shops or direct from Associated Chemists Ltd, 61 Wicker, Sheffield, S3 8HT.

**PLEASE NOTE:** When draining down the water system, it is wise to remove the water tank filler cap to prevent the possibility of air locks in the system. If you are laying the vehicle up before winter (or frosty weather) make sure the water pump as well as the water tank is free of water.

**INSIDE THE VEHICLE:** The fresh water tank is fitted with a water level gauge, the dial and controls of which are situated on the control panel fitted beside the wardrobe. To set the dial, turn on the motor caravan 12 volt system, depress the button beneath the water level gauge and adjust the calibration knob with the water tank full. Please bear in mind the fact that the water level gauge is not precise in its accuracy and can vary with water from different areas of the country. Consequently, re-calibration may be necessary during your motor caravanning journeys.

The sink and cooker flaps are held up by means of the chrome anti-splash guards.

The electric water pump feeding water to the sink is operated by a foot switch on the floor thus leaving the hands free for other tasks. Treat the foot switch with care; it will give years of trouble free operation if looked after, but is easily broken if kicked or heavy objects are dropped upon it.

The sink waste water drains to a point almost immediately below the sink and should be collected in a waste bucket. Alternatively, a waste tank can be fitted as original equipment during manufacture of your Villa.

**GAS SUPPLY & COOKING:** The conversion is designed to carry two Camping Gaz containers (2.72Kg size) in a sealed compartment in the base of the wardrobe. Gas containers can be obtained from Gaz dealers and from many caravan sites. They must be used with the appropriate regulator and the suppliers recommend that flexible rubber hose from the regulator to the gas piping should be replaced every year. This system is very efficient in use, but all gas fuel is potentially dangerous, and should any leaks be suspected the supply should be turned off immediately and the system checked by an authorised dealer. It is essential that the gas supply should always be turned off at the container when the vehicle is driven because of the risk of fire or explosion in the event of an accident.

Care should be taken not to damage any exposed gas piping when packing or using the vehicle. **DO NOT** obstruct gas ventilation holes in floor of vehicle, they are specifically to allow the escape of gas in the event of a leak.

Full manufacturers instructions are supplied with the cooker. The cooker flap top is held up by the fold out chrome splash guard. The cooker should never be used without adequate ventilation in the van as otherwise there will be a build up of fumes.

In draughty situations, especially in windy weather, it may be found that the gas burners may blow out, and although your Villa cooker unit is fitted with a flame failure device (which automatically cuts off the gas supply to the burner in question should its flame be blown out), it is vital to check for this eventuality so that the control knob can be returned to 'off' and the lighting sequence be commenced all over again.

When the gas supply in a gas cylinder is coming towards the end, it will be found that the gas burners appear to burn low with a yellow flickering to the flame, and it will then be necessary to change gas cylinders.

The gas cooker must not be used as a space heater - a specially designed caravan heater can be fitted to your vehicle by most competent motor caravan dealers if required.

**THE SPINFLO THREE BURNER AND GRILL COOKER:** Your Villa is fitted with the latest type of stainless steel three burner and grill cooker, which will prepare high quality meals quickly and efficiently. This unit is the Spinflo combination unit, and it is for this unit that these instructions particularly apply.

**Lighting the appliance:** Turn on the gas supply at the gas regulator and at the appropriate gas tap in the wardrobe.

To operate either of the three burners, depress the appropriate burner knob and turn in an anti-clockwise direction until the indicator of the knob coincides with the large flame symbol. Apply a match to the burner and keep the knob depressed for a further 10-15 seconds until a flame is established. Turn the knob as far as it will go in an anti-clockwise direction. This indicates the bottom of the simmer range.

By turning the knob clockwise, a larger flame can be obtained. To turn off, turn the knob clockwise to the off position when a stop will be reached; then release and the tap will spring out. See diagram below:

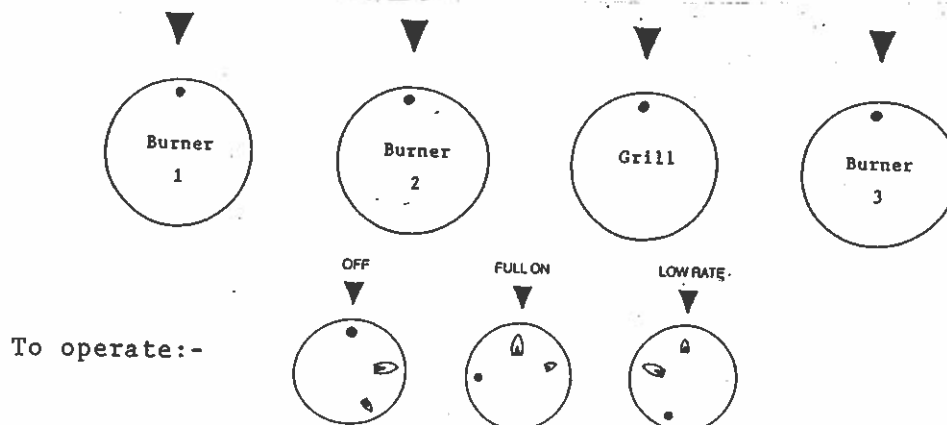

Never allow a full flame to burn without a utensil over the burner as this is wasteful and it may also result in heat damage to the underside of the cooker lid or the headlining immediately above the cooker. Care should also be exercised in operating gas taps, because of the restricted space between the chrome windshield and the taps, this area can become extremely hot when the burners are alight.

**Please note:** Gas may take some time to reach the burners, (or other appliances) if the motor caravan has not been used for some time, or a fresh cylinder is fitted. When lighting the cooker use a taper or match, if it fails to ignite the first time, make one further attempt with a naked flame held against the burner for 20 seconds, but if it fails to light, check the gas supply.

Follow the above operation for the other burner and the grill. Under no circumstances should the kitchen unit lid be lowered while the cooker unit is alight, nor should it be lowered until the complete cooker unit has cooled down. Always keep the fold-down door in front of the grill unit in the open position while the grill is being used.

Care should also be taken to avoid scorching the laminate immediately adjacent to the cooker. While this material is a genuine heat resistant plastic laminate, it can be damaged when the burner jet is on full heat and a pan so placed that the flame heat is directed against the surround.



**WARNING! RISK OF FIRE**

There is always the risk of fire in a motor caravan. Use care and common sense; in particular:

DO NOT use gas appliances while vehicle is on the move and DO NOT use gas appliances - including refrigerator on gas - when filling vehicle with petrol.

Turn off regulator and secure gas cylinder for road travel.

Keep curtains, seat covers and other inflammable items WELL AWAY from cooker and other gas appliances.



WATER SYSTEM

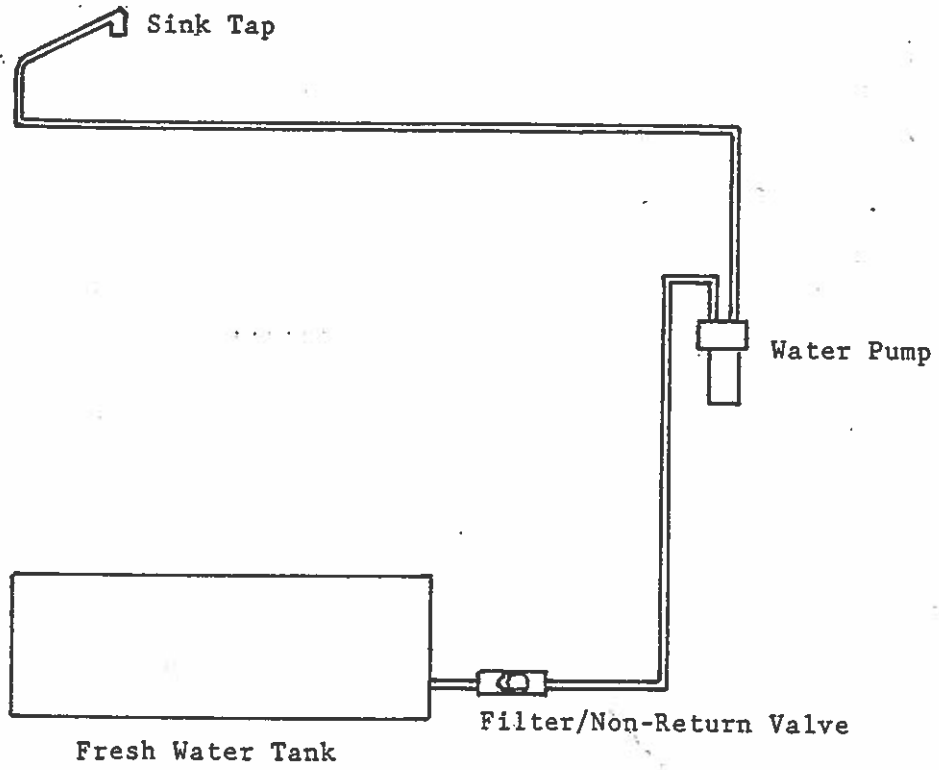

GAS SYSTEM

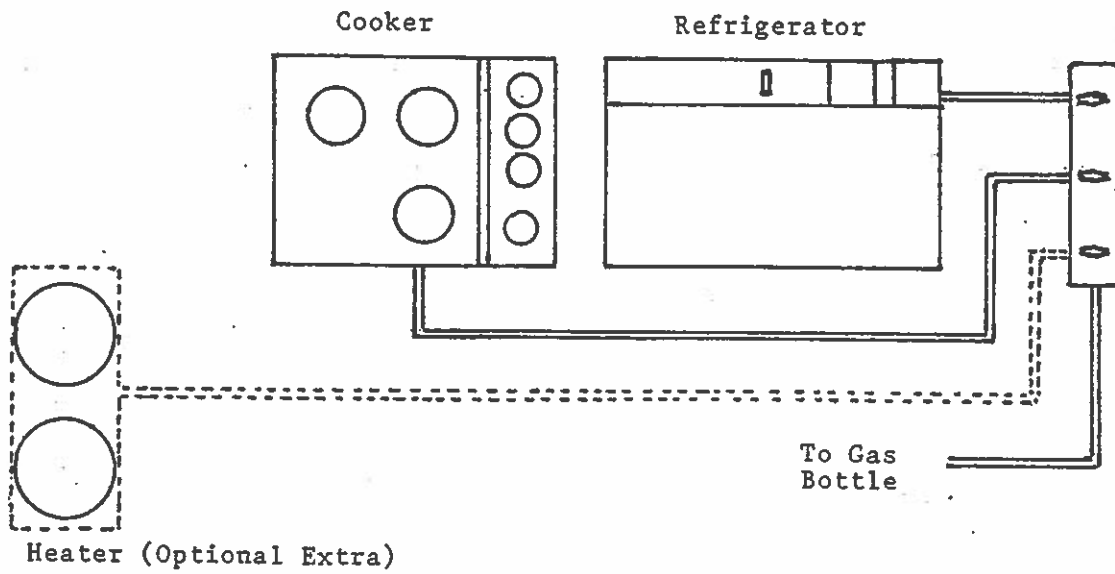

## ELECTRICAL SYSTEMS & FITTINGS

**CARAVAN 12 VOLT ELECTRICAL SYSTEM:** Your Villa motor caravan is equipped with a comprehensive electrical system with both 12 volt and 220/240 volt circuits to provide comfortable motor caravanning under a wide variety of conditions. Naturally, the fluorescent lights consume the least electricity and these can be operated for some considerable time, along with the 12 volt water pump, without risking a 'dead' vehicle battery. However, if one is staying for along duration in one spot, it is wise to start the vehicle engine from time to time simply to make sure that there is enough reserve in the battery. Relatively short journeys in the vehicle will re-charge the battery.

The left hand rocker switch on the SP-4 distribution panel will dictate whether the caravan 12 volt appliances are operated from the vehicle battery (by pushing the switch at the top) or the optional caravan battery (bottom). The centre position for this switch turns off power to all 12 volt appliances. Once the left hand switch has been set, the appropriate 12 volt appliance can be operated with the use of the three other rocker switches plus - of course - the switches on each individual appliance. The following appliances are controlled by the switches:

- |        |   |                             |
|--------|---|-----------------------------|
| PUMP   | - | Water pump                  |
| LIGHTS | - | All fluorescent lights      |
| AUX 1  | - | Heating systems (if fitted) |
|        |   | Water level gauge           |

The main vehicle accessories (such as vehicle lights, windscreen wiper etc) are protected by fuses contained in a fuse box located behind the panel in the dashboard to the right of the driver. (see your Volkswagen manual for details). The caravan fuses are fitted in the engine compartment to the right of the main battery. There are two fuses - each of 25 amp (1) to protect the refrigerator and (2) the Zig control panel.

### OPTIONAL EXTRA

The Villa can be fitted with a DCU/3 caravan battery charger unit, which would be connected to the SP-4 control panel by Peter Everard Limited, Cashes Green Road, Stroud, Glos GL5 4RA and separate instructions have been provided by the manufacturers. This unit is designed to ensure that the caravan (secondary) battery can be charged by the mains electrical supply if this is available. The unit automatically prevents overcharging and a battery condition warning light on the control panel indicates when the 12 volt system is switched on. the caravan battery is automatically charged from the alternator when the vehicle engine is running via the split charging relay fitted beneath the vehicle driver's seat.

To remove the 25 amp line fuse, unscrew the white plastic bayonet fitting. To replace the 15 amp fuse on the charging unit, turn the black plastic cap and the fuse will be exposed. Carry spare fuses at all times. However, if fuses continually blow, an auto electrician - or your Villa supplier - should be consulted for the root cause of the problem.

#### CARAVAN MAINS ELECTRICAL SYSTEM - 200-240 VOLT A.C.

The caravan is equipped with mains electrical equipment for use with a mains supply fed to the vehicle via a di-pole connector to the vehicle input unit mounted on the rear corner of the vehicle, behind a white pull-up flap. Supply can be obtained from any 220/240V source using a special type feed cable - (IEC 364/P+7/708), which is obtainable from your caravan dealer.

This will enable use to be made of any ordinary 240 volt electrical mains equipment such as portable TV's, vacuum cleaners, razors, hair driers etc, always providing that the total current demanded by the equipment does not exceed the available supply current. This equipment is used from the 13 amp power socket mounted next to the SP4 distribution panel.

The mains supply can also be used to re-charge the optional caravan battery through the Zig charging unit. Full protection is built into the design to ensure that the mains supply is isolated from the 12 volt caravan and vehicle battery circuits. The earth leakage circuit breaker gives protection against faults, this being located in the wardrobe. It is recommended that each time before using mains equipment, you should check the operation of this protection device. This is simply done by switching on the mains supply and the circuit breaker switch and pressing in the black tongue above the switch, when the switch should immediately fly 'off' again. This indicates the circuit breaker is operational and the switch can then be reset to 'on'.

**NOTE:** For additional protection, these three switches are of the industrial type for which the supply is 'on' when the switch is in the 'up' position - the opposite to most domestic switches.

**TO USE FROM THE MAINS SUPPLY AT HOME:** The motor caravan can be plugged into an ordinary domestic 240 volt supply before you leave for your holiday (you can 'cool down' your refrigerator in this way). To do this you will need to obtain the appropriate electrical lead from your supplying motor caravan dealer, or, alternatively, from a good caravan or motor caravan accessory shop. Please note that although the vehicle connector and flap provides splash protection, it should not be regarded as completely waterproof and it is not recommended that it is used when the vehicle is being washed.

**TO USE THE MAINS SUPPLY FROM A CARAVAN SITE 'HOOK-UP':** It is necessary to purchase a suitable made up lead incorporating a plug to fit the vehicle socket and one to fit 'hook-up' supply points. These will be moulded into the cable so that they are waterproof. Nevertheless they should be used with care and should always be clean and dry when connected as camp sites often provide wet conditions due to rain, mist and dew. Again the earth leakage circuit breaker should be tested before use. These made-up leads can be purchased from good caravan supply shops.

**Supply cables should always be fully uncoiled when they are used!**

**SWITCHING PROCEDURE:** To use the van power socket connect up the supply cable and switch on as follows:

- 1) Switch on at the house or caravan site socket.
- 2) Switch on the earth leakage circuit breaker (ELCB), test as described on page 14 and switch on again.
- 3) Switch on the 15 amp switch (the centre one of the group of three on the ELCB unit).
- 4) Switch on the van power socket.
- 5) Switch on the appliance if necessary.

To use the domestic supply to charge the optional battery, connect up the supply cable and switch as follows:

- 1) Switch on at the house or caravan site socket.
- 2) Switch and test the earth leakage circuit breaker and switch on again.
- 3) Switch on the 5 amp switch (the left one of the group of three on the ELCB unit).
- 4) Operate the switch of the charging unit which will illuminate amber.

The optional caravan battery should now be charging. An automatic cut-out is fitted if it should overheat, but charging will be interrupted.

The Zig unit does not charge the main vehicle battery.

Provided the supply current is adequate, use of the power socket and battery charging can proceed simultaneously.

The 240 volt mains battery charging circuit is protected by a 2 amp fuse on the charging unit. The supply must be 'off' before the fuse is removed and it is necessary to use a screw driver to remove the fuse cap - this is to comply with electrical safety regulations.

After using the mains supply and removing the supply cable, close the white plastic flap cover to the connector on the outside of the vehicle to prevent it swinging and becoming damaged.



Multi-Pin 'D' Connector  
(Located rear of fuse box)

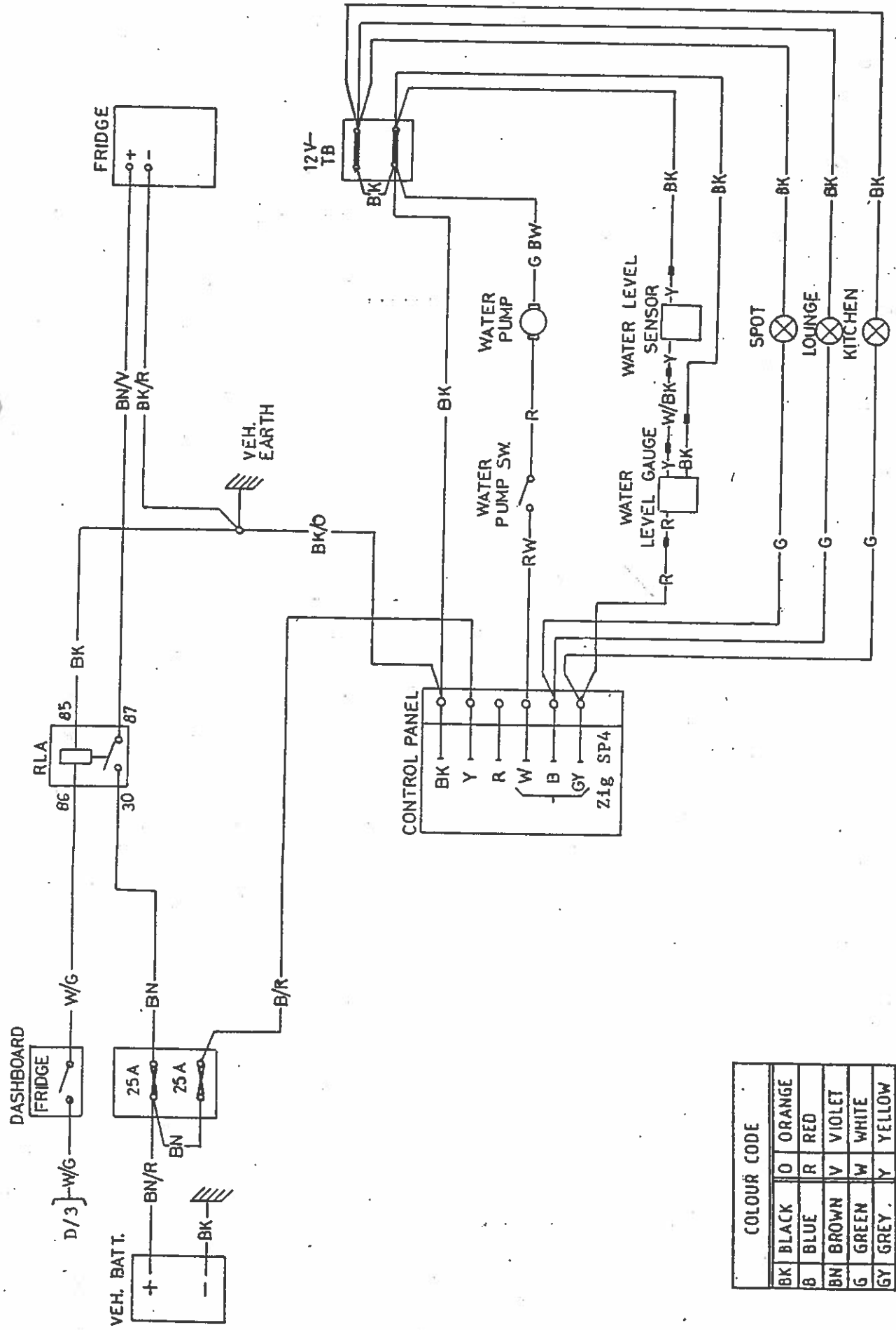

COLOUR CODE	
BK	BLACK
O	ORANGE
B	BLUE
R	RED
BN	BROWN
V	VIOLET
G	GREEN
W	WHITE
GY	GREY
Y	YELLOW

T4 VILLA 12V WIRING DIAGRAM

WIRING DIAGRAM 240VOLTS (MAINS)

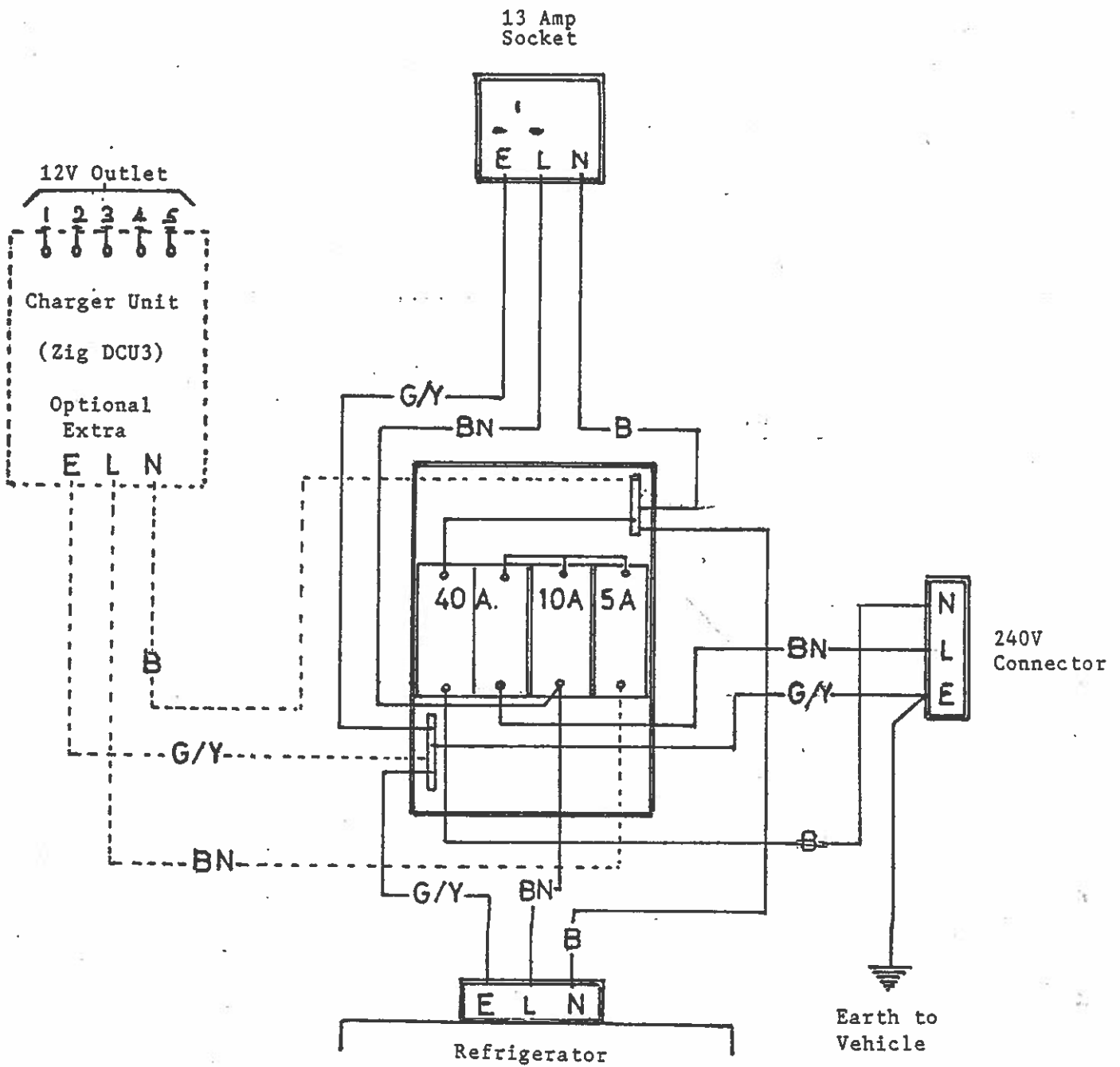

Cooker/Sink  
Combination Unit

Earth to  
Vehicle

Colour Code			
BN	Brown	L	Live
B	Blue	N	Neutral
G/Y	Green/Yellow	E	Earth

Connect direct to Alternator Terminal 'D+'

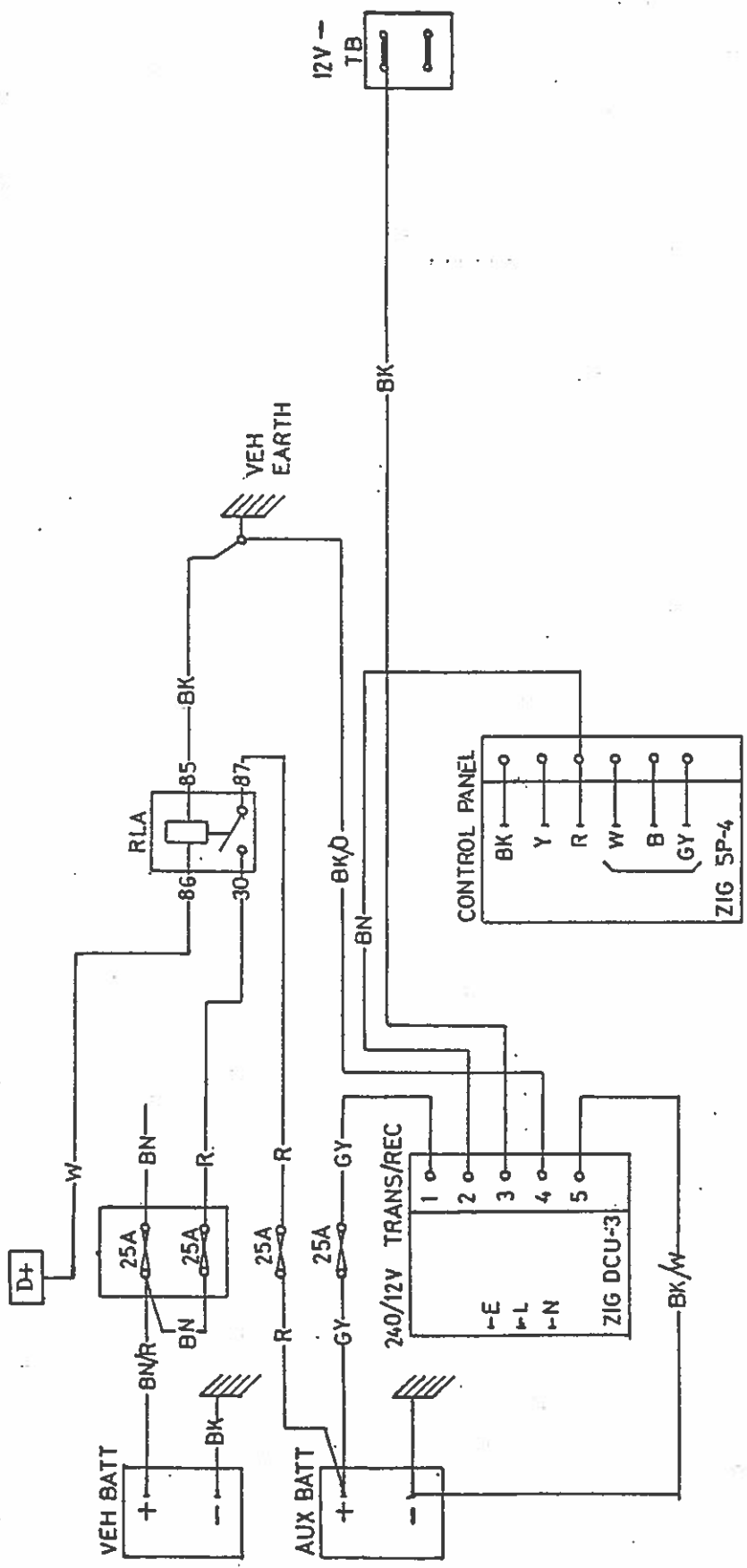

COLOUR CODE	
BK	BLACK
O	ORANGE
B	BLUE
R	RED
BN	BROWN
V	VIOLET
G	GREEN
W	WHITE
GY	GREY
Y	YELLOW

WIRING DIAGRAM

T4 VIELA/VISION AUX. BATTERY (OPTIONAL EXTRA)

**REFRIGERATOR:**

Your Villa motor caravan is fitted with the excellent Camping Gaz CTL 175 top loading refrigerator, which operates from vehicle electrics while the vehicle is on the move, from mains when on a site with this facility and gas when camping in the 'wild'.

This is a particularly efficient refrigerator and you should find that it retains its cold better than a front opening refrigerator, and you may even be able to turn it off from time to time, and it will still keep produce fresh.

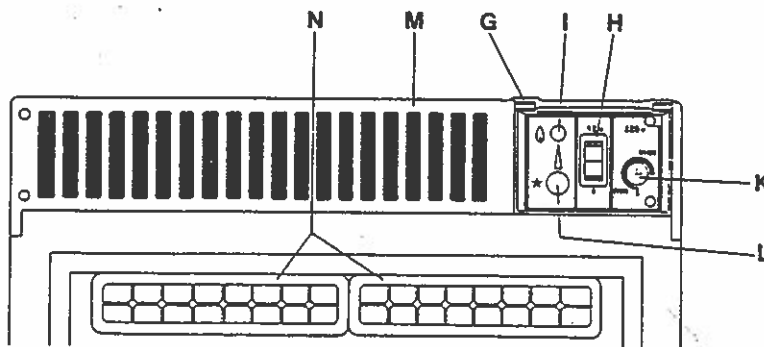

**Operation on gas:** Turn on the gas supply at the regulator on top of the gas bottle and then the appropriate isolating tap to the fridge within the wardrobe. Open the flap to the refrigerator controls on the top of the refrigerator, and set the 12 volt rocker switch (H) to the 'O' position. Fully push down the gas security button - I - for some 20/30 seconds so that any air in the system is purged. While keeping this button down, press the Piezo electrical igniter button - L - sharply three or four times. The fridge should light immediately (as indicated by the needle swinging from white to green on the flame indicator) or there will be a distinct 'pop' as the flame ignites and then goes out. Repeat the operation with the gas security button depressed throughout. Presuming that there is an adequate supply of gas to the refrigerator, it will light shortly - release the gas security button some 15/20 seconds later. Check once again that the flame is burning satisfactorily by observing the position of the needle on the flame indicator - if the needle returns at any time to the white position, the flame has extinguished whereupon the gas supply to the fridge should be turned off and the gas cylinder checked to see whether it is empty.



**WARNING!!** Always turn off the gas supply to the refrigerator at the gas isolating tap when the refrigerator is off or not operating on gas.

**To Turn Off/Gas Supply to Fridge:** To turn off the fridge the gas tap in the wardrobe must be turned fully off. (This is the only method of turning off the fridge.)



**Operation on 12 volt electrics:** Operation on 12 volt (vehicle) electrics should only be performed when the vehicle engine is running, ~~or the vehicle battery will be drained in a matter of a few hours.~~ *THE FRIDGE ONLY RUNS OFF 12V WHEN ENGINE IS RUNNING*

You will find a toggle type switch to the left of the steering wheel on the dashboard. Turn to 'on' (lower position) to operate 12 volt power to the refrigerator. Set the toggle switch on the refrigerator control panel to 12 volt (switch 'H'), then start the vehicle and finally turn on dash switch. *(EITHER BEFORE)*

The refrigerator will now be operating from the vehicle electrics while on the move and will keep perishables cold' but it must be remembered that all caravan type refrigerators are not as efficient on 12 volt electrics and it is asking a great deal of the fridge to, say, form ice cubes.

**Operation on mains electrics:** Hooking the vehicle up to mains electrics is covered on page 15 of your User Manual and should be followed at all times.

Having established a mains supply, make sure all switches on the ELCB in the wardrobe are in the 'on' position (up). Turn the 12 volt fridge control toggle switch to the 'off' position and ensure that there is not a gas supply to the fridge. You are now free to control the temperature of the appliance by means of progressively turning the knob to the extreme right of the fridge control panel - knob 'K' on the diagram.

**Removal of refrigerator:** The Camping Gaz CTL 175 refrigerator can be removed from it's recess in your Villa for cleaning of the burners, service or repair. However, we would point out this is a task for your local professional caravan service centre or Camping Gaz dealer - it should NOT be tackled by amateurs.

**NOTE:** Enclosed with the user manual for your new Villa motor caravan are separate instructions for the Camping Gaz refrigerator and a complete list of service and repair centres in Britain and throughout Europe. Please contact your nearest approved Camping Gaz approved service centre for service or repair of your refrigerator.

It is essential that the vehicle battery is disconnected before working on 12 volt fitment. All 12 volt appliances in this vehicle must be turned off before the battery or batteries are disconnected. The mains hook up (if fitted) **MUST** be disconnected before working on the vehicle or conversion. Adjustment or servicing of 220 volt appliances **MUST** be left to a competent electrician.

**ELEVATING ROOF:**

The elevating roof that can be specified on the Villa motor caravan is of a patented design with features not seen on other motor caravans, and should give first class service for many years to come.

**WARNING:**

UNDER NO CIRCUMSTANCES SHOULD THE VEHICLE BE DRIVEN WITH THE ROOF UP!! Make sure that the roof bed sliding panel (if fitted) is located securely in the roof aperture, and that the spring pins have been fitted to the roof catches before driving off.

Note: Maximum permissible loading for luggage area is 10kg (see note page 7)

DO NOT carry heavy items on the roof bed - either the fixed or sliding portions - while the vehicle is on the move

The roof is retained in the lowered position by four over-centre catches fitted to the exterior of the roof - one is fitted to each corner of the roof. A spring pin is provided and can be inserted in the catch to prevent it from jumping off. Fitment of the pins is recommended whenever the vehicle is driven.

To raise the roof, release the four exterior catches and from inside the vehicle press on the centre panel - once the roof is raised by a few inches the gas struts will take over and the roof will raise unaided most of the way. The roof is raised the last few inches simply by pushing the two end panels into position - this is achieved on the rear panel by means of the cranked handle which pushes the panel outwards and then locks it into place. Note: The cranked handle must push on the panel from the INSIDE of the panel, and it may be necessary to 'jockey' the roof into position - either upwards or downwards - to achieve the correct position.

To lower the roof is to reverse the operation detailed above. Hook the cranked handle behind the hook on the rear end panel and pull inwards - make sure the cranked handle is returned to a position in which the hook lies flat against the roof top and locked or it will damage itself, the roof bed cushions or the end panel when the roof is fully lowered.

Note: Ventilation can be achieved in the roof top by leaving one or both end panels in the slightly open position, or by opening the roof ventilator.

**MAINTENANCE:** Very little maintenance will be needed on the Villa solid sided elevating roof. However, if you examine the elevating roof base plinth recesses - front and rear - where the gas strut tubes are located you will see that each recess is provided with drain holes which must be kept clear at all times. Failure to do this will cause the recesses to fill with water making the metal work and gas struts prone to rust.

At the top of the roof there are aluminium channels, and it is important that these are kept well greased using a car-type grease obtainable from most garages. Failure to do so could cause the roof to seize up with resultant damage to the mechanism. The runners can be greased twice a year or more frequently if the grease is prone to drying up. Oil the bearings where the gas struts hinge on the roof with a three in one oil, and it is also sound practice to wipe the gas strut shaft with a three in one oil particularly if the roof is kept in the open position for any length of time.

Naturally, the roof benefits from being kept clean and it is recommended that it be washed off when the rest of the vehicle is washed. Wipe excess water from the roof side and end panels after washing along with the gas strut tubes.

During washing, do NOT direct a water hose jet against any joints in the roof side or end panels - or at the bottom piano hinges or at the top of the side and end panels.

### CARE & MAINTENANCE OF YOUR MOTORCARAVAN

We recommend that the outside of your vehicle is kept clean in the usual way. We also recommend that the vehicle is regularly serviced by a reputable garage.

**THE INTERIOR:** We recommend that the interior of the vehicle is cared for in the usual manner. Specifically the following can be referred to:

- CARPETS:** Vacuum as usual. A dry (powder) cleaner can be used if necessary.
- CURTAINS:** Curtains are washable on a 40 wash cycle.
- WOODWORK:** Use of a normal household polish is recommended, particularly to remove scuff marks.
- WINDOWS:** These can be cleaned using a normal household window cleaner. However, extreme care should be exercised when cleaning the heated rear window, and this should only be cleaned using a damp wash leather.
- WALL/HEADLINING:** The interior head lining should be kept clean by regular vacuuming.
- WORK SURFACES:** A damp cloth or household polish can be used.
- UPHOLSTERY:** This should be kept clean by regular vacuuming. Any stains should be removed as quickly as possible by soaking up any excess fluid, and then using a well wrung cloth. There are also proprietary cleaners on the market that are specifically designed for modern fabrics, including carpets, curtains, and the fabrics used for the headlining and on the side panels of your vehicle. In particular, we would suggest the use of 'Vanish' soaps and aerosol cleaners to remove stains and marks on all soft furnishings in the conversion; these cleaners are available at most stores, but if you experience difficulties - write to the manufacturer - Benckiser Ltd., Electra House, Farnsby Street, Swindon. SN1 6AH (Tel:0793 612422) Please note that the labels should be read with care first.



**CARE & MAINTENANCE OF YOUR MOTORCARAVAN CONTINUED....**

24

**COOKER:**

Cleaning is best carried out when the hob is still warm but not hot. Never start cleaning the hob before all taps and isolation switch have been switched off. Do not keep aerosols or inflammable products in the cupboards and drawers in the immediate vicinity of the hob.

It is important that all burner ports are kept clean and free from blockage. Wash in soapy water only. To unblock the flame ports use a brush with hard bristles. Dry carefully before reassembly and ensure they are resealed in venturi correctly.

Do not use abrasive cleaner. Polish with a dry cloth or chamois leather. Clean up spillages of acidic liquids immediately, i.e. lemon juice, vinegar etc.

**LEAKAGE OF GAS** - A leak will smell! If a leak is suspected, turn off all appliances and check connections with soapy water. Tighten if necessary. If smell persists, turn off gas at cylinder and immediately contact a qualified caravan dealer who is Corgi registered.

**IMPORTANT:** Do not use penetrating oil on gas taps. If in doubt, contact the manufacturers.

**ELEVATING ROOF:**

See instructions on pages 21 and 22.

**EXTERIOR STRIPES:**

When cleaning the exterior of your motor caravan care should be exercised so that the vehicle stripes and Richard Holdsworth names and logos are not damaged. In particular, care should be shown when cleaning around the area of the stripes and logos to prevent them from 'lifting'. The manufacturer will not wish to be held responsible for damage caused in this way.

**REAR LADDER:**

The rear ladder on your Villa motor caravan may be constructed from aluminium or a similar alloy which has a number of advantages, but needs regular cleaning to keep it in pristine condition. This is especially so during frosty weather when anti-icing salts are applied to the roads; these salts need to be washed off the vehicle including the ladder every day to avoid corrosion.

**IN GENERAL:**

Every new Richard Holdsworth motor caravan is supplied with a copy of the S.M.M.T. booklet giving advice on annual service and checks for your motor caravan conversion and we thoroughly recommend that the advice contained therein is followed in detail. Further copies of this booklet can be obtained from most motor caravan dealers or from Richard Holdsworth Conversion Ltd, at £1.20 each plus 50p handling charge.

**OPTIONAL EXTRA****PROPEX HEATER**

Your Richard Holdsworth motor caravan may be fitted with the optional Propex heater which is a useful feature for motor caravanning in colder conditions or in winter.

The heater should be ordered so that it can be fitted as original equipment at the time of building the motor caravan conversion in the Richard Holdsworth factory. The heater can be installed at a later date by the companies recommended by the heater manufacturers. If in doubt, contact the heater manufacturers:-

Propex Marketing Ltd  
Unit 5  
Blackmore Road  
Ebblake Industrial Estate  
Verwood Dorset  
BH21 6BB                      Telephone: 0202-823538/9

It is pointed out that the cost of fitting the heater at a later date may well be greater than when fitted as original equipment due to the additional work involved.

**OPERATION:**

The heater is operated by two controls - the thermostat dial and the function switch.

The thermostat dial selects the temperature and has a range of about 35 C starting at approximately 0°C. The function is selected by the 3-way switch. If heat is to be selected, press the switch on the side of the small flame and if cool air is to be blown, press the switch on the side of the propeller. When heat is selected, the red power light will glow and if the thermostat dial is set high enough, the green light will come on and the heater will automatically ignite. If the cool air vent facility is selected, the red power light will turn green and the heater fan will run without the burner being lit.

**WARNING:**

The heater is a particularly safe unit in that the combustion area is completely sealed from the inside of the vehicle. In other words, the air to be warmed is drawn into the unit through the fixed vent, passed over the combustion chamber and returned into the vehicle via the multi-directional vent. The combustion chamber is fed from air drawn in beneath the vehicle and exhausted through another pipe also beneath the vehicle.

**OPTIONAL EQUIPMENT CONTINUED....**

Care should be taken at all times the unit is running, that neither of the vents inside the vehicle are blocked, as this could lead to the unit running poorly and becoming over-heated.

In the same way, periodic checks should be made to make sure the inlet and exhaust pipes beneath the vehicle have not become blocked and if the motor caravan is used in snow IT IS ESSENTIAL THAT THE PIPES BENEATH THE VEHICLE BE KEPT FREE FROM SNOW AT ALL TIMES; failure to do this could cause inefficient operation of the heater or - at worst - a complete shutdown.

**FLYSCREEN(High Top Only)**

To remove flyscreen for cleaning purposes, first prise out the grey rubber strip in the window channel from the inside of the vehicle. Then from outside the vehicle pull edge of flyscreen in the middle of window towards you, which will release the flyscreen from the top and bottom channels. Slide towards centre window.

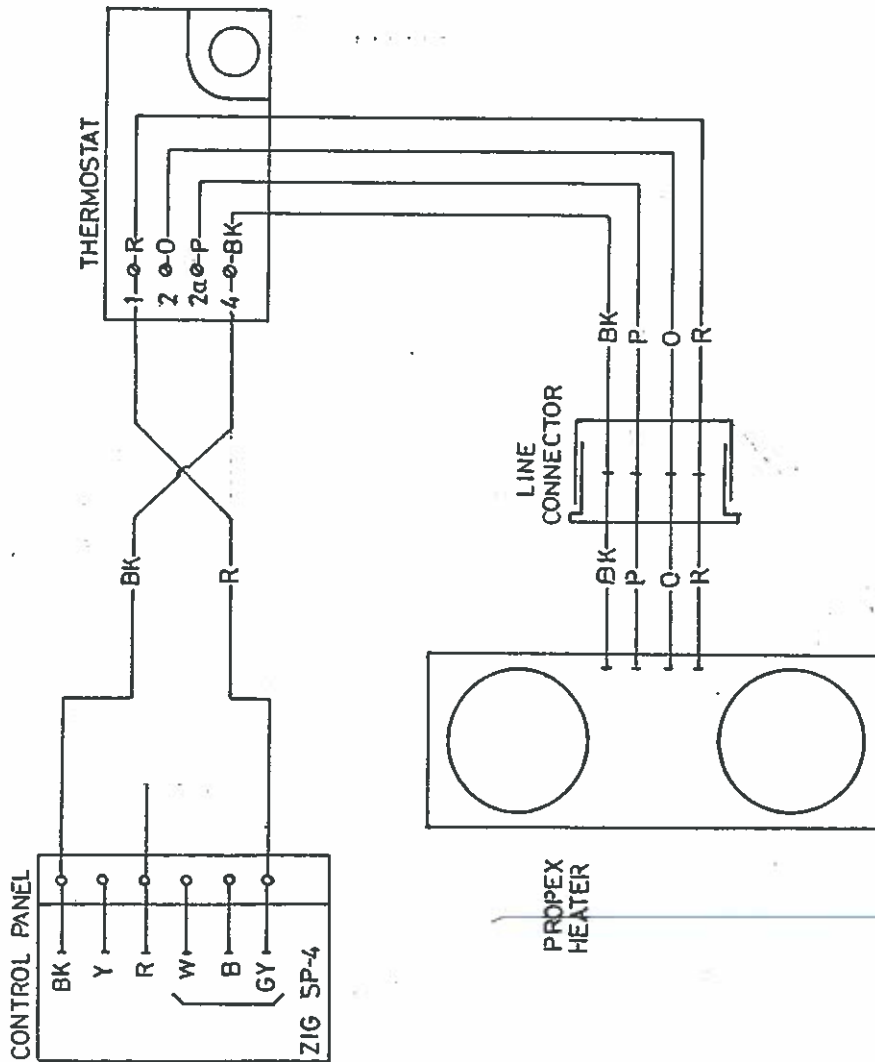

Colour Code	
R	Red
O	Orange
P	Purple
BK	Black

WIRING DIAGRAM - VILLA/VISION T4  
 PROPEX X2 COMPACT HEATER & ELECTRONIC THERMOSTAT

**TECHNICAL DATA****Conversion on SWB 1.0 Kombi - 4 Cylinder Petrol/Diesel****WEIGHT:**

MODELS	G.V.W.	KERB WEIGHT	MAX PAYLOAD	MAX ROOF LOADING
Elevating Roof Villa	2515kg	1974kg	541kg	10kg
High Top Villa	2515kg	1959kg	556kg	15kg

KERB WEIGHT consists of fully converted van, full tank of fuel, and drinking water, spare wheel, and tool kit.

KERB WEIGHT does not include driver, passengers, personal effects, camping equipment nor food stuffs.

**DIMENSIONS:**

Overall Length:	4.655m
Overall Width:	1.84m
Overall Height (closed)	2.210m
Elevating Roof: (elevated)	2.695m
Overall Height High Top:	2.495m

**BEDDING CAPACITY:**

Standard 2 berth-  
with  
Option Extra -  
Upper Berth for  
2 Juveniles

**CAPACITIES:**

Fresh Water Tank:	59 litres
Gaz cylinder:	2.72kg Butane (x2)





# CONTROL PANEL SERIES

# INSTRUCTIONS FOR USE

## GUARANTEE

Thankyou for purchasing a ZIG product.  
Peter Everard Ltd., and its subsidiary Zig Electronics Ltd., Guarantee this product against failure due to faulty workmanship and/or material for a period of 12 months from the date of original purchase.

This Guarantee will be extended when the product is fitted to a caravan or motor-caravan by an original equipment manufacturer, the term will then be 12 months from the date that the caravan first became the subject of a retail sale.

It shall be at the company's discretion to determine the method of rectifying the fault.

This Guarantee is not transferable and any claims made under the Guarantee MUST be made to the supplier from whom the product was purchased; (or to the dealer who supplied the caravan originally). It is important that proof of the date of purchase is supplied by the customer.

In the event of a claim under this Guarantee please do one of the following things:

1. Return the product or the caravan to the original supplier together with proof of the date of purchase.
2. Contact the dealer for information about repairs in situ.

Please check the section on "Fault Finding" before making any claim under the Guarantee.

### IMPORTANT

This guarantee will be invalidated if any attempt has been made to open, modify or repair by unauthorised personnel.

Fuses and fuseholders are not covered for failure or damage by whatever cause.

.....

What to do if a problem occurs outside the Guarantee period:

1. Ask your local caravan dealer if he can service the unit for you.
2. Contact a qualified electrician (or if the problem is confined to the 12 volt circuits), a qualified auto-electrician.
3. If 1 and 2 above are not practical or unsuccessful, you may return the product to the manufacturers: Peter Everard Ltd., at Cashes Green, Stroud, Glos. GL5 4RA subject to the following:

- (a) The product is packaged in accordance with Post Office requirements, i.e. a minimum of 2" (50mm) of packing material around the parcel: Peter Everard Ltd., will not be responsible for any damage in transit.
- (b) A letter describing full details of the fault, including how and when it occurred.
- (c) A cheque for £17.50 (incl. vat) made payable to Peter Everard Ltd. This is to defray charges for checking and return postage. If any repairs required exceed this figure you will be advised in writing before repairs commence. Should you decide not to proceed the above amount will be returned to you less the cost to return postage.

.....

This Guarantee does not in any way affect your statutory rights.

ZIG ELECTRONICS LTD., CASHES GREEN, STROUD GLOS. GL5 4RA.

COPYRIGHT, Peter Everard Ltd. 1988

WARNING: This document is copyright, it may not be reproduced in any form, copied, or in any way retrieved for any purpose whatsoever except with the written consent of the publishers.

Zig Electronics Ltd.,  
83, Cashes Green Road,  
Stroud, Glos. GL5 4RA

## CONTROLS

All the accessory switches are clearly marked with their functions, except the auxiliary switches these outlets allow for a choice of equipment when the panels are fitted as standard by your caravan manufacturer. These switches, together with their separate fuses serve to isolate the various 12 volt outlets in your caravan and allow you to choose which circuits you wish to use at any time.

The main control switches are the "Caravan Battery/Car Battery" control and the "12V ON/OFF" control this is in the centre position on some panels and their operation is as follows:

### BATTERY SELECTOR (Caravan battery/Car battery)

This switch does exactly as its name implies; it allows you to choose the source of 12 volt supply to your caravan. It is a feature of all ZIG control panels and will be found very useful, especially when on sites without a mains supply for battery charging. The ability to utilise your car battery to run your caravan accessories will allow much longer time before recharging. At the same time the facility will allow you to be independent of your car by using the caravan battery only.

Note. Permanent use of the car battery only will inevitably result in the infuriating situation of a fully charged caravan battery and a car which won't start!

### THE 12V ON/OFF SWITCH

This switch serves to isolate all 12V circuits in the caravan and also the ZIG battery condition indicator, it is similar to the main circuit breaker in your house, the one you turn off before you go away on holiday. N.B. Some caravans which are fitted with electrically controlled heating systems need to have a permanent supply to thermostats etc., if you have such a system check your instruction book before turning off the 12V supply during periods when the caravan is in use.

### THE BATTERY CONDITION INDICATOR

This device is fitted to all ZIG control panels, its purpose is to warn that the batteries are becoming discharged and to allow remedial action to be taken. The red light will glow when the battery voltage is below 11 volts, above this voltage the green light will glow. No harm will come to the system or the battery if the accessories are used when the red light is on, and it will be found that possibly another few days reserve of current is available after the red light first appears. A true reading will only be given when all the 12 volt equipment is switched off and when no charging system is in operation. The red light may come on when an appliance is switched on, this is normal - current surges cause momentary voltage drop. It is important to remember that the battery monitor is not a charging indicator. The fact that the green light is on does not mean that the battery is fully charged. Even with a flat battery the green light will glow if a charging system is operating, due to the high terminal voltage present at the battery.

## BATTERY CHARGING FROM THE MAINS

None of the ZIG Control Panels covered in this publication incorporate any facilities for battery charging, their function is confined to the safe control of the low voltage circuits in your caravan together with system and battery state indication. These products were however designed to be used in conjunction with the ZIG DCU3 and DCU15 AUTOMATIC REMOTE BATTERY CHARGERS.

## BATTERY CHARGING FROM THE CAR

Most modern installations allow charging of the caravan battery when the vehicle is connected to the caravan (and the vehicle engine is running), the wiring for this is usually incorporated in the caravan during manufacture. However it is unfortunately true that very few car manufacturers make provisions for proper operation of caravan electrical supply and it is usually left to the owner of the vehicle to make his own modifications in order to take full advantage of the sophisticated electrical systems available in today's caravan. Fortunately these modifications are not too difficult or expensive and can be completed by the owner in a few hours. Full details follow in the next paragraph.

## WIRING YOUR CAR

The most important aspect of any modification to your car's wiring is safety; there is no possibility of getting an electric shock from a 12 volt supply but low voltage/high current supplies are the ideal way to start fires, and a fire in a caravan is probably even more dangerous than one in a car. PROPER FUSING IS ESSENTIAL. The complete system requires three separate cables to be run from the car battery positive terminal to the 12S socket fitted on the lowbar. It is very important that the proper cable is used, the MINIMUM recommended size of cable is 2mmsq (27.02) and thicker cable will give higher current capability if physical space allows. Wiring should commence at the 12S socket by first ensuring a good earth connection to the car chassis to Pin 3 on the socket, this is most easily accomplished by running a cable direct to bare metal a short distance away from the socket. The other three wires should be run either underneath the vehicle or through an available channel directly back to the engine compartment. It is most important that these cables be protected by a proper fusing system and the easiest way to accomplish this is to fit an in-line fuseholder in each cable before it is connected to a supply. Note: The fuses must be fitted as close to the battery as possible, any cable between the battery and the fuse is unprotected and therefore a potential fire hazard. The cables from No. 4 and No. 6 of the 12S socket should be connected through the previously fitted fuse links to the POSITIVE terminal of the vehicle battery, using proper terminations to the battery posts.

The cable from Pin No. 2 of the 12S socket should be connected through a relay switched via the ignition switch of the vehicle, fitting will depend on the relay used; (full fitting instructions are included with the ZIG RM12 relay, only four connections are required). When all the connections are completed and carefully checked, insert a 25 amp fuse in each fuseholder and check out the system



TO BE RETAINED BY THE MOTOR CARAVAN OWNER FOR FUTURE REFERENCE

**RICHARD HOLDSWORTH CONVERSIONS LTD.**  
**WARRANTY CERTIFICATE**  
(BODY CONVERSION ONLY)

R.H.C. ORDER No. V1177/92  
CHASSIS MAKE VOLKSWAGEN T4 CHASSIS No. 70NH070962  
FULL CONVERSION MODEL No. VILLA NON ROOF  
REGISTRATION No.  
SUPPLYING DEALER'S NAME  
DATE PURCHASED  
DEALERS ADDRESS

Richard Holdsworth Conversions Ltd. (hereinafter called "the Company") hereby guarantee the body conversion of the Motorised Caravan details of which are specified above against failure or defect arising through defects in workmanship or material under normal use and service for a period of one year from the date of purchase.

Subject to the limitations and conditions hereinafter specified the Company will during the said period repair or replace free of charge any defects which arise in the body of the conversion and which is found on the Company's inspection to result solely from faulty design, workmanship or materials. It is also a condition of this Warranty that the said Motorised Caravan is delivered to an authorised dealer or distributor of the Company or the Company's factory for any such repair (at the Company's discretion) and afterwards collected therefrom both at the sole expense of the Purchaser.

**REGISTRATION CARD**

TO BE FILLED IN BY SUPPLYING DEALER AND RETURNED TO:

Richard Holdsworth Conversions Limited,  
Headley Road East, Woodley, Reading, Berks, RG5 4NE.

MODEL VILLA NON ROOF R.H.C. ORDER No. V1177/92  
REGISTRATION No. CHASSIS No. 70NH070962  
SUPPLYING DEALERS NAME  
ADDRESS  
DATE OF PURCHASE  
OWNER'S NAME Mr. Mrs. Miss  
ADDRESS  
SIGNED  
SALESMAN'S NAME (Please Print)